

External Holders

C1 to C36

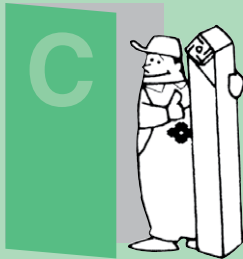

Negative Insert Holders	CN <input type="checkbox"/> <input type="checkbox"/> Applicable Insert Holders	SEC-External Tool Holder Series..... C2	
	DN <input type="checkbox"/> <input type="checkbox"/> Applicable Insert Holders	SEC-External Tool Identification Table..... C4	
	T-REX Tool Holders	SEC-Double Clamp D Type Tool Holders..... C6	
	SN <input type="checkbox"/> <input type="checkbox"/> Applicable Insert Holders	DCLN Type / PCLN Type..... C7	
		PCBN Type / PCFN Type..... C8	
		DDJN Type / DDHN Type / DDNN Type..... C9	<input type="checkbox"/> C
		PDJN Type..... C10	
		SumiTurn T-REX Tool Holders..... C11	
		DSBN Type / DSDN Type..... C13	<input type="checkbox"/> D
		DSSN Type / PSSN Type..... C14	
	PSDN Type / PSBN Type..... C15		
	PSKN Type / ESBN Type..... C16	<input type="circle"/> R	
	ESDN Type / ESKN Type..... C17		
	ESSN Type..... C18		
	DTGN Type / DTFN Type..... C19	<input type="checkbox"/> S	
	PTGN Type / PTTN Type..... C20		
	PTFN Type..... C21		
	ETGN Type / ETAN Type..... C22	<input type="triangle"/> T	
	ETFN Type..... C23		
	ETEN Type / ETXN Type..... C24		
	MTJN Type / MTXN Type..... C25	<input type="checkbox"/> V	
	DVJN Type / DVVN Type / DVQN Type..... C26		
	DWLN Type / PWLN Type / MWLN Type..... C27	<input type="hexagon"/> W	
Positive Insert Holders	RCM <input type="checkbox"/> <input type="checkbox"/> Applicable Insert Holders	PRGC Type / PRDC Type..... C28	
	CC <input type="checkbox"/> <input type="checkbox"/> · DC <input type="checkbox"/> <input type="checkbox"/> · VC <input type="checkbox"/> <input type="checkbox"/> Applicable Insert Holders	SCLC Type / SDJC Type / SVJC Type..... C29	
	SP <input type="checkbox"/> <input type="checkbox"/> Applicable Insert (No Hole) Holders	SVLC Type / SVVC Type / SVPC Type..... C30	
	TP <input type="checkbox"/> <input type="checkbox"/> Applicable Insert (No Hole) Holders	CSRP Type / CSDP Type / CSKP Type (FP11 / 14 / 15 Type)..... C31	
	Aluminium Wheel Turning Holders	CTGP Type / CTFP Type (FP21 / 22 / 25 Type)..... C32	
		Tool Holders for Aluminum Wheel Turning..... C33	
		SEC-MV Type Copying Tool Holders..... C34	
		SEC-GD Type Copying Tool Holders..... C35	
		Double Clamp Tool Holders..... C36	
		Clamp Set Parts..... C36	

Stock Indications and Symbols

- mark: Standard stocked item
- mark: To be replaced by a new item featured on the same page
- ▲ mark: To be replaced by new item (Please confirm stock availability)
- * mark: Semi-standard stock (Please confirm stock availability)
- mark: Stock or planned stock (Please confirm stock availability)
- No mark: Made-to-order item
- mark: We cannot produce

SEC- External Tool Holder Series



General Features

Since the development of the Top-clamp Sec-2 type holders in 1959 and the cam-lock Sec-3 type the following year, Sumitomo Electric Hardmetal has had more than 50 years of experience in producing and developing indexable holders. Presently, Sumitomo Electric Hardmetal provides a wide variety of top quality external turning tools to satisfy any machining need with reliable and consistent performance.

* SEC : Steady & Easy Clamp is the generic code for our indexable holders.

TOOLING SELECTION

Structure	Application Insert Type Series	General Turning & Facing		General Turning & Copying		General Turning			
		80° Diamond Type C		55° Diamond Type D		Triangular Type T			
Double Clamp	SEC-M SEC-D	DCLN C7	DDJN C9	DDHN C9	DDNN C9	DTGN C19	DTFN C19	MTJN C25	MTXN C25
	T-REX	—	—	DTR55C (T-REX) C11	DTR55Q (T-REX) C11	—	—	—	—
Pin Lock	SEC-30	—	—	—	—	ETGN ETAN C22	ETFN C23	ETEN C24	ETXN C24
Lever Lock	SEC-70 ⊗ Side lever locking system	PCLC D17 D24	PCLN C7	PDJC D16 D19	—	PTGN C20	PTTN C20	PTFN C21	PTXN D18
		PCBN C8	PCFN C8	PDJN C10	—	—	—	—	—
Screw-on	Mini Holder	SCLC C29 D17 D24	SCAC D17 D24	SDJC C29 D16 D19	SDAC D16 D19	STGC D29	STAC D29	—	—
		—	—	SDNC D19	SDPC D16	Clamp-on SEC-40	CTGP (FP21/FP22) C32	CTFP (FP25) C32	—

* Symbols in () indicate the previous product types. * Figures in <> indicate the front cutting edge angle of the holder. Be careful of interference during machining.

SEC- External Tool Holder Series

■ Performance Comparison Table

Series	Clamp Mechanism						Rake Angle		Clamp Rigidity	Handing	Index Tolerance	Chip Control	Legend
	P	E	C	M	S	D	Negative	Positive					
SumiTurn T-REX Tool Holders						○	○		◎	◎	◎	○	<Clamp Mechanism> P : Lever Lock
SEC-D Type Tool Holders						○	○		◎	◎	◎	○	E : Pin Lock
SEC-70 Type Tool Holders	○						○		◎	◎	◎	◎	C : Top Clamp
SEC-30 Type Tool Holders		○					○		△	○	△	◎	M : Pin & Top Clamp
SEC-M Copying Holders				○			○		◎	◎	○	○	S : Screw Lock
SUMIBORON PR Type Holders	○								◎	◎	◎	◎	D : Double Lock

◎: Excellent ○: Good △: Good
◎: Most strongly recommended

■ TOOLING SELECTION

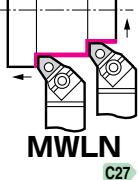
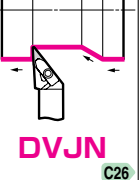
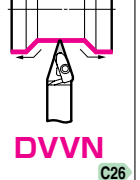
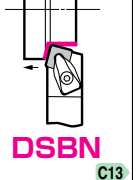
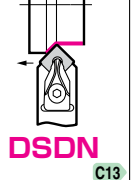
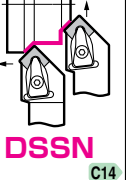
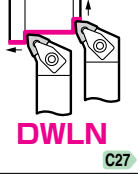
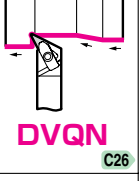
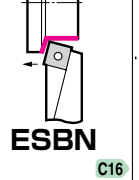
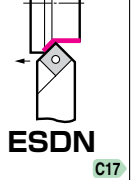
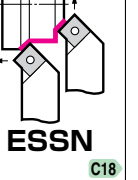
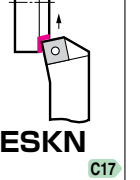
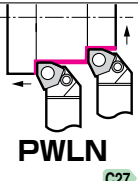
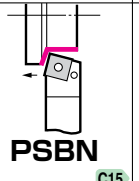
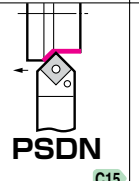
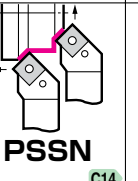
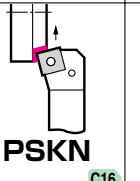
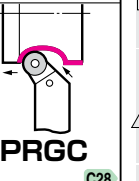
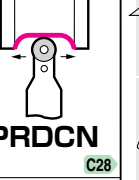
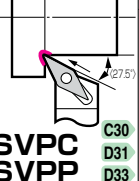
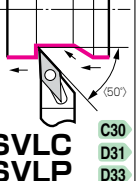
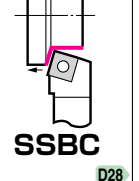
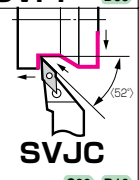
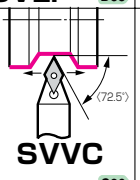
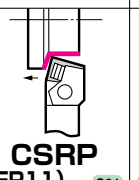
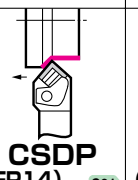
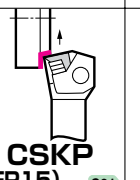
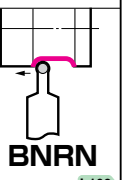
Structure	Application Insert Type Series	General Turning	General Turning & Copying		General Turning				Special Turning
		Hexagon Type W	35° Diamond Type V		Square Type S				Round Type R
Double Clamp	SEC-M SEC-D	 MWLN C27	 DVJN C26	 DVVN C26	 DSBN C13	 DSDN C13	 DSSN C14	—	—
		 DWLN C27	 DVQN C26	—	—	—	—	—	—
Pin Lock	SEC-30	—	—	—	 ESBN C16	 ESDN C17	 ESSN C18	 ESKN C17	—
Lever Lock	SEC-70	 PWLN C27	—	—	 PSBN C15	 PSDN C15	 PSSN C14	 PSKN C16	 PRGC C28
		—	—	—	—	—	—	—	 PRDCN C28
Screw-on	Mini Holder	—	 SVPC C30 D31 D33	 SVLC C30 D31 D33	 SSBC D28	—	—	—	—
	SEC-SV	—	 SVJC C29 D18	 SVVC C30	Clamp-on SEC-40 SEC-R	 CSRP (FP11) C31	 CSDP (FP14) C31	 CSKP (FP15) C31	 BNRN L108

* Symbols in () indicate the previous product types * Figures in <> indicate the front cutting edge angle of the holder. Be careful of interference during machining.

Catalogue Classification System For SEC-Tool Holders

■ Catalogue Classification System For SEC-Tool Holders

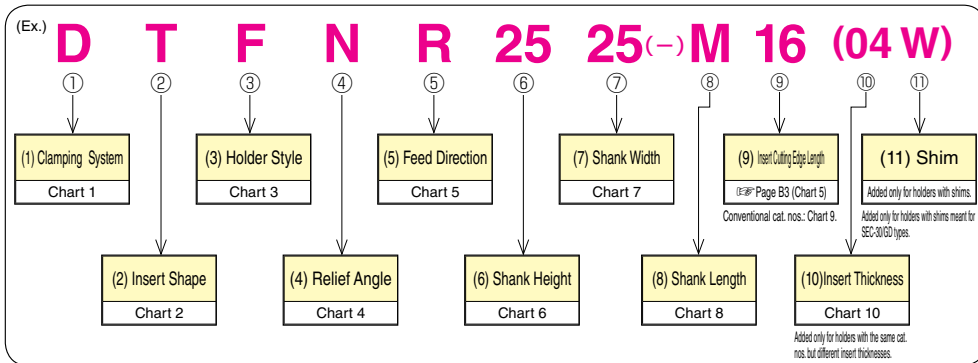

● Identification Example

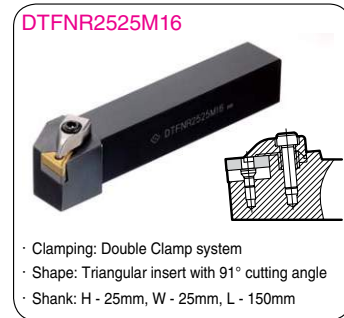

Chart 1

(1) Clamping System					
Symbol	System	Structure	Symbol	System	Structure
C	Top Clamp		M	Top Clamp + Pin Lock	
D	Double Clamp		P	Lever Lock (Insert is supported by 2 faces)	
E	Pin Lock (Insert is supported by 1 face)		S	Screw Lock	

Chart 2

(2) Insert Shape			
Symbol	Insert Shape	Symbol	Insert Shape
A	Parallelogram 85° Apex Angle	M	Diamond 86°
B	Parallelogram 82° Apex Angle	O	Octagonal
C	Diamond 80°	P	Pentagonal
D	Diamond 55°	R	Round
E	Diamond 75°	S	Square
F	Diamond 50°	T	Triangle
H	Hexagon	V	Diamond 35°
K	Parallelogram 55° Apex Angle	W	Trigon
L	Rectangular		

Chart 4

(4) Relief Angle	
Symbol	Relief Angle
A	3°
B	5°
C	7°
D	15°
E	20°
F	25°
G	30°
N	0°
P	11°
O	Special Angle

Chart 5

(5) Feed Direction					
Symbol	Right Hand	Symbol	Left Hand	Symbol	Neutral
R		L		N	

Chart 3

(3) Holder Style (— Indicates major cutting edge)					
Symbol	Shaped	Off-set	Symbol	Shaped	Off-set
A*		None	L		Yes
B		None	N		None
D		None	R		Yes
E		None	S		Yes
F*		Yes	T		Yes
G*		Yes	U		Yes
J		Yes	W		Yes
K		Yes	Y		Yes

Chart 6

(6) Shank Height		(7) Shank Width	
Symbol	Height (mm)	Symbol	Width (mm)
12	12	12	12
16	16	16	16
20	20	20	20
25	25	25	25
32	32	32	32
40	40	40	40
50	50	50	50

2 digits are used for each dimension in mm.

Chart 7

Chart 10

(10) Insert Thickness			
Symbol	Thickness (mm)	Symbol	Thickness (mm)
X1	1.40/1.80*	04	4.76
01	1.59	05	5.56
02	2.38	06	6.35
T2	2.78	07	7.94
03	3.18	09	9.52
T3	3.97		

Chart 8

(8) Shank Length	
Symbol	Length (mm)
F	80
H	100
K	125
M	150
N	160
P	170
Q	180
S	250
T	300
U	350

For some previous cat. nos., a hyphen (-) is used instead of a letter.

Chart 9* Applicable for conventional cat. nos. only.

Inscribed Circle		Insert Thickness	
Symbol	Inscribed Circle (mm)	Symbol	Thickness (mm)
3	9.525	2	3.18
4	12.70	3	4.76
5	15.875	4	6.35
6	19.05	5	7.94
8	25.40	6	9.52

Conventional cat. nos. combine the I.C. number and the insert thickness number to form a two-digit indication.

For round inserts:

Symbol	Inscribed Circle (mm)
10	10
12	12
16	16
20	20
25	25
32	32

*91° on our products

*CCET03X1→1.40, CCET04X1→1.80

Position of Cutting Point

Position of Cutting Point and Nose Radius

● Cutting point position in relation to the nose radius (ISO Standard)

Values for X and Y indicated in the table below are given when lateral rake angle and cutting edge angle are 0°.

Tool Shapes			Dimensions (mm)			Tool Shapes			Dimensions (mm)		
Symbol	Shapes	Close-up of Cutting Edge	r_ϵ	X	Y	Symbol	Shapes	Close-up of Cutting Edge	r_ϵ	X	Y
A			0.4	0.291	—	K			0.4	0.024	0.089
			0.8	0.581	—				0.8	0.048	0.178
			1.2	0.872	—				1.2	0.072	0.268
			1.6	1.162	—				1.6	0.096	0.357
			2.4	1.743	—				2.4	0.143	0.535
B			0.4	0.089	0.024	L			0.4	0.040	0.040
			0.8	0.178	0.048				0.8	0.079	0.079
			1.2	0.268	0.072				1.2	0.119	0.119
			1.6	0.357	0.096				1.6	0.159	0.159
			2.4	0.535	0.143				2.4	0.238	0.238
D			0.4	0.164	0.164	N			0.4	0.463	0.263
			0.8	0.329	0.329				0.8	0.925	0.471
			1.2	0.493	0.493				1.2	1.388	0.707
			1.6	0.658	0.658				1.6	1.850	0.943
			2.4	0.986	0.986				2.4	2.776	1.414
E			0.4	0.396	0.229	S			0.4	0.164	0.164
			0.8	0.793	0.458				0.8	0.329	0.329
			1.2	1.190	0.687				1.2	0.493	0.493
			1.6	1.587	0.916				1.6	0.658	0.658
			2.4	2.381	1.374				2.4	0.986	0.986
F			0.4	—	0.291	T			0.4	0.396	0.229
			0.8	—	0.581				0.8	0.793	0.458
			1.2	—	0.872				1.2	1.190	0.687
			1.6	—	1.162				1.6	1.587	0.916
			2.4	—	1.743				2.4	2.381	1.374
G			0.4	0.291	—	U			0.4	0.253	0.058
			0.8	0.581	—				0.8	0.506	0.116
			1.2	0.872	—				1.2	0.759	0.175
			1.6	1.162	—				1.6	1.013	0.233
			2.4	1.743	—				2.4	1.519	0.350
J			0.4	0.344	0.033	Y			0.4	0.002	0.033
			0.8	0.687	0.079				0.8	0.005	0.066
			1.2	1.031	0.118				1.2	0.008	0.099
			1.6	1.375	0.157				1.6	0.011	0.132
			2.4	2.062	0.236				2.4	0.017	0.198

● Nose radius position calculation

Calculation Formula		(mm)	Values of "d" and "r _ε " for the calculation of "B" (mm)				
Shaped	Formula		Inscribed Circle Dimension	"d" Value	Nose R Code	Dimension	"r _ε " Value
	Triangle	$B=3/2d-r_\epsilon$	3.97	3.9688	02	0.2	0.203
	Square	$B=(\sqrt{2}-1)\times(d/2-r_\epsilon)$	4.76	4.7625	04	0.4	0.397
	Diamond	$B=(1/\sin(\theta/2)-1)\times(d/2-r_\epsilon)$	5.56	5.5562	08	0.8	0.794
			6.35	6.3500	12	1.2	1.191
			7.94	7.9375	16	1.6	1.588
			9.525	9.5250	24	2.4	2.381
			12.70	12.7000			
			15.875	15.8750			
			19.05	19.0500			
			25.40	25.4000			

Double Clamp D Type Tool Holders

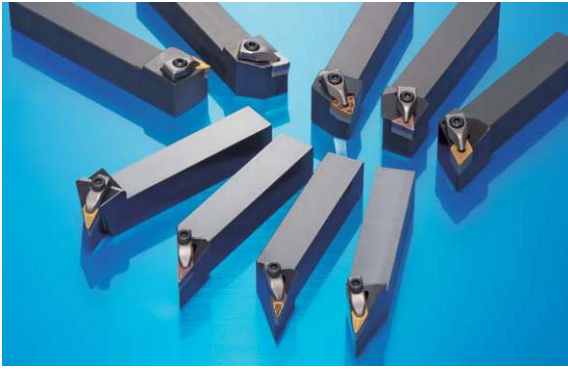

Characteristics

- Insert is clamped firmly for improved fracture resistance.
- High indexing accuracy improves machining accuracy.
- Insert can be changed from below the holder.
- Suitable for high efficiency machining and interrupted cutting in hardened steel.

Clamp Mechanism

Secured in two directions and supported by two faces

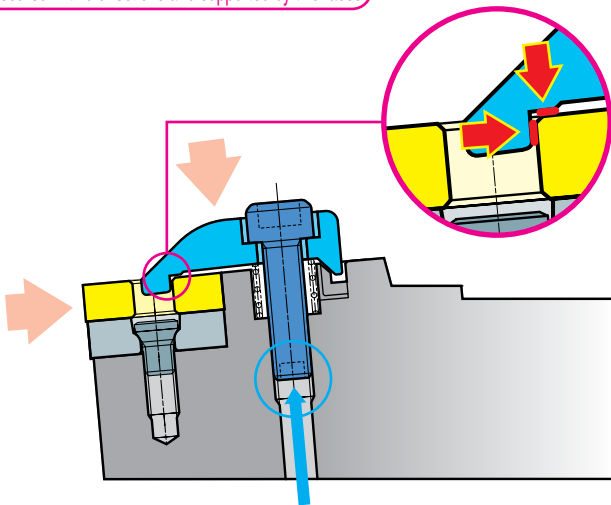

Insert can be changed from below the holder

Index Accuracy Comparison (Length wise)

D Type Tool Holders

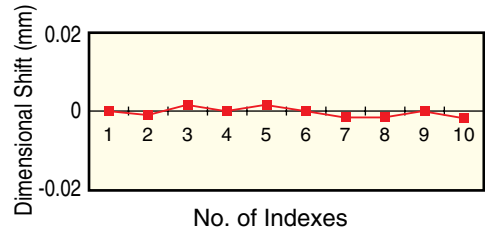

Lever Lock

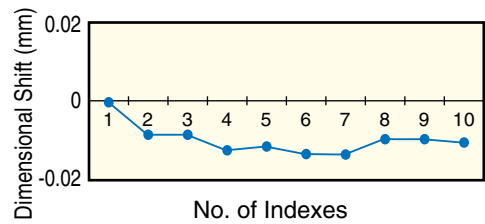

Application Examples

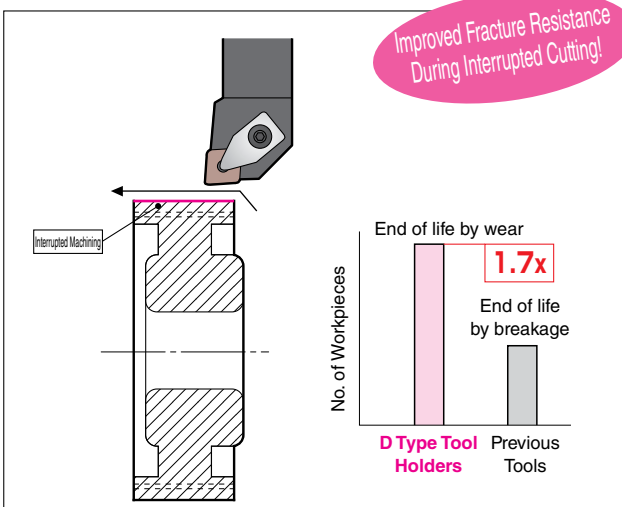

Holder : DCLNL2525M12
 Insert : CNMG 120408N-SU
 Grades : EH510Z(→Changed to AC510U)
 Work Material : Sintered Alloy
 Cutting Conditions : $v_c=150\text{m/min}$ $f=0.3\text{mm/rev}$ $a_p=0.2\text{mm}$ Wet

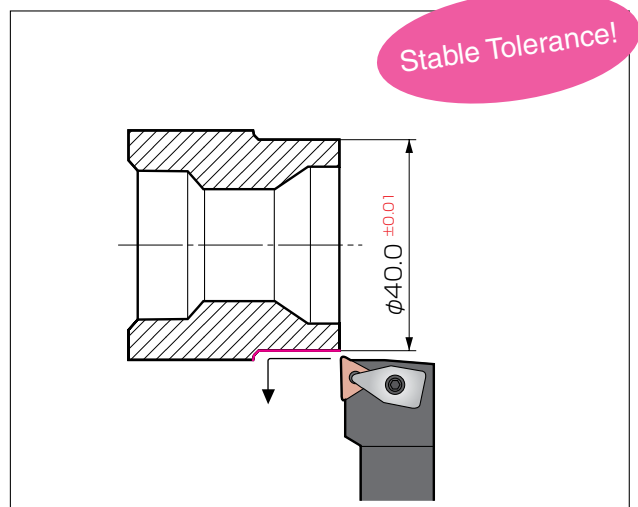

Holder : DTGNR2525M16
 Insert : 6NC-TNGA160408
 Grades : BNC150(→Changed to BNC160)
 Work Material : SCR420H(60HRC)
 Cutting Conditions : $v_c=150\text{m/min}$ $f=0.15\text{mm/rev}$ $a_p=0.1\text{mm}$ Dry

External Holders

Negative Inserts

C

D

R

S

T

V

W

Special

DCLN / PCLN Type

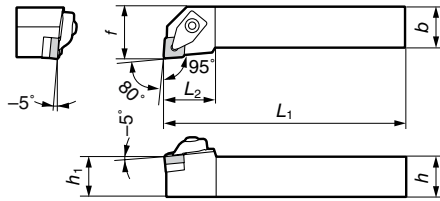
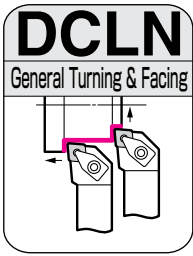
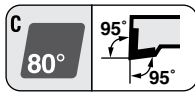

SEC- D Type Tool Holders

General Turning and Copying
Double Clamp

Spare Parts

* Item is sold separately

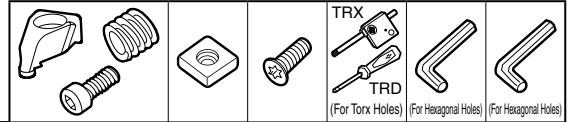

Holdings

Above figures show right hand tools.

Cat. No.	Stock		Dimensions (mm)						Applicable Inserts		Clamp Set	Recommended Tightening Torque (N·m)	Shim	Shim Screw	Shim Spanner	Spanner for Upper Surface	Spanner for Lower Surface
	R	L	h	b	L ₁	f	h ₁	L ₂	Cat. No.	Ref. Page							
DCLN R/L2020K12	●	●	20	20	125	25	20	32	CN□□1204	From B21	SCP-2	5.0	CNS1204	BFTX0409N	TRX15 (*)	LH040	LH025
DCLN R/L2525M12	●	●	25	25	150	32	25	32	CN□□1606	From B24	SCP-3	5.0	CNS1606	BFTX0509N	TRX20 (*)	LH040	LH025
DCLN R/L2525M16	●	●	25	25	150	32	25	32									
DCLN R/L3232P16	●	●	32	32	170	40	32	32	CN□□1906	From B26	SCP-5	5.0	CNS1906	BFTX0511N	TRX20 (*)	LH040	LH025
DCLN R/L3232P19	●	●	32	32	170	40	32	42									
DCLN R/L4040S19	●	●	40	40	250	50	40	42	CN□□2509	B29	SCP-6	6.0	CNS2509	BFTX0615N	TRD25(*)	LH060	—
DCLN R/L4040S25	●	●	40	40	250	50	40	53									

Clamp Set Parts

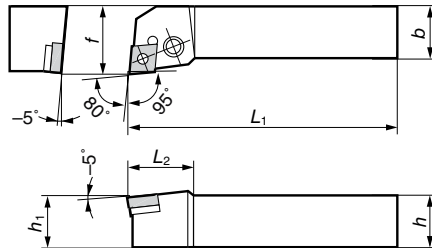
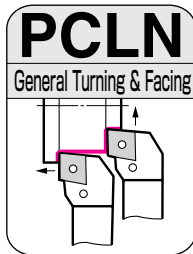

SEC- 70 Type Tool Holders

General Turning and Copying
Lever Lock

Spare Parts

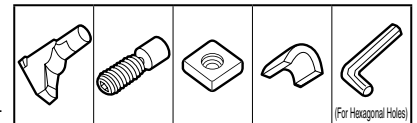

Holdings

Above figures show right hand tools.

Cat. No.	Conventional Cat. No.	Stock		Dimensions (mm)						Applicable Inserts		Lever Pin	Bolt	Shim	Shim Pin	Spanner
		R	L	h	b	L ₁	f	h ₁	L ₂	Cat. No.	Ref. Page					
PCLN R/L1616H0903	PCLN R/L1616-32	●	●	16	16	100	20	16	20	CN□□0903	B20	LCL3	LCS3	LSC32	LSP3	LH025
PCLN R/L2020K0904	PCLN R/L2020-33	●	●	20	20	125	25	20	20	CN□□0904	B21	LCL3	LCS3	LSC317	LSP3	LH025
PCLN R/L2525M0904	PCLN R/L2525-33	●	●	25	25	150	32	25	20							
PCLN R/L2020K12	PCLN R/L2020-43	●	●	20	20	125	25	20	28	CN□□1204	From B21	LCL4	LCS4	LSC42	LSP4	LH030
PCLN R/L2520M12	PCLN R/L2520-43	●	●	25	20	150	25	25	28							
PCLN R/L2525M12	PCLN R/L2525-43	●	●	25	25	150	32	25	28	CN□□1606	From B24	LCL5	LCS5	LSC53	LSP5	LH030
PCLN R/L3225P12	PCLN R/L3225-43	●	●	32	25	170	32	32	28							
PCLN R/L3232P12	PCLN R/L3232-43	●	●	32	32	170	40	32	28	CN□□1906	From B26	LCL6	LCS6	LSC63	LSP6	LH040
PCLN R/L2525M16	PCLN R/L2525-54	●	●	25	25	150	32	25	33							
PCLN R/L3225P16	PCLN R/L3225-54	●	●	32	25	170	32	32	33	CN□□1906	From B26	LCL6	LCS6	LSC63	LSP6	LH040
PCLN R/L3232P16	PCLN R/L3232-54	●	●	32	32	170	40	32	33							
PCLN R/L3225P19	PCLN R/L3225-64	●	●	32	25	170	32	32	38	CN□□1906	From B26	LCL6	LCS6	LSC63	LSP6	LH040
PCLN R/L3232P19	PCLN R/L3232-64	●	●	32	32	170	40	32	38							
PCLN R/L4040R19	PCLN R/L4040-64	●	●	40	40	200	50	40	38							

Applicable Inserts ◀ DCLN / PCLN / PCBN / PCFN Type

Recommended Inserts

- Please also refer to the selection guide for inserts. (from page A8)
- Some combinations need to be made-to-order or cannot be manufactured.

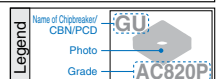

Applications Cutting State	P (Steel)			M (Stainless Steel)			K (Cast Iron)			N (Non-ferrous)	H (Hardened Steel)	
	Finishing	Medium	Rough Cutting	Finishing	Medium	Rough Cutting	High-Speed/Finishing	Finishing to Medium Cutting	Medium to Rough Cutting	—	Coated	Non-coated
Continuous Cutting	SU T1500Z	GU AC810P	MU AC820P	EF AC610M	EG AC6030M	EM AC6030M	SUMIBORON BN7000	UZ AC405K	GZ AC405K	SUMIDIA DA1000	SUMIBORON BNC2010	SUMIBORON BN1000
General Cutting	SU AC810P	GU AC820P	MU AC820P	EF AC6030M	EG AC6030M	EM AC6040M	SUMIBORON BN7000	GZ AC415K	GZ AC415K	SUMIDIA DA1000	SUMIBORON BNC2020	SUMIBORON BN1000
Interrupted Cutting	SX AC820P	UX AC830P	MX AC830P	EF AC6030M	EG AC6040M	EM AC6040M	SUMIBORON BN7000	GZ AC420K	No Breaker AC420K	SUMIDIA DA1000	SUMIBORON BNC300	SUMIBORON BN350
Recommended Cutting Conditions	From A8			From A18			From A22			From A32	From A28	

C External Holders

Negative Inserts

C

D

R

S

T

V

W

PCBN / PCFN Type

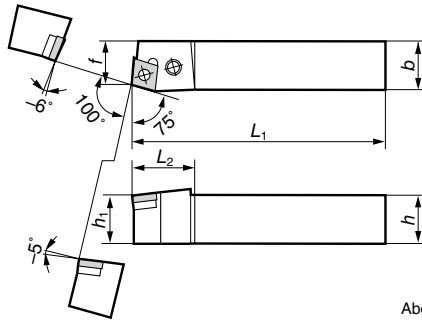
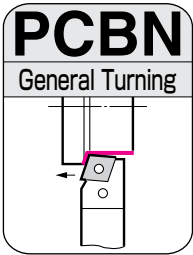
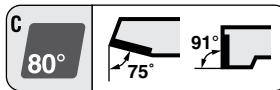

SEC- 70 Type Tool Holders

General Turning and Copying

Lever Lock

Spare Parts

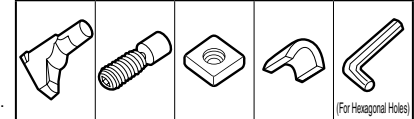

External Holders

Cat. No.	Conventional Cat. No.	Stock		Dimensions (mm)						Applicable Inserts		Lever Pin	Bolt	Shim	Shim Pin	Spanner
		R	L	h	b	L ₁	f	h ₁	L ₂	Cat. No.	Ref. Page					
PCBN R/L2020K12	PCBN R/L2020-43	●	●	20	20	125	17	20	27	CN□□1204	From B21	LCL4	LCS4	LSC42	LSP4	LH030
PCBN R/L2520M12	PCBN R/L2520-43	●	●	25	20	150	17	25	27							
PCBN R/L2525M12	PCBN R/L2525-43	●	●	25	25	150	22	25	27							
PCBN R/L3225P12	PCBN R/L3225-43	●	●	32	25	170	22	32	27	CN□□1606	From B24	LCL5	LCS5	LSC53	LSP5	LH030
PCBN R/L2525M16	PCBN R/L2525-54	●	●	25	25	150	22	25	33							
PCBN R/L3225P16	PCBN R/L3225-54	●	●	32	25	170	22	32	33							
PCBN R/L3232P16	PCBN R/L3232-54	●	●	32	32	170	27	32	33	CN□□1906	From B26	LCL6	LCS6	LSC63	LSP6	LH040
PCBN R/L3232P19	PCBN R/L3232-64	●	●	32	32	170	27	32	38							
PCBN R/L4040R19	PCBN R/L4040-64	●	●	40	40	200	35	40	38							

Above figures show right hand tools.

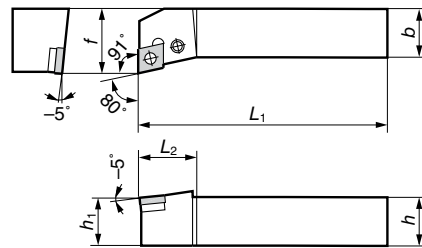
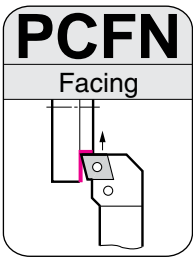

SEC- 70 Type Tool Holders

General Turning and Copying

Lever Lock

Spare Parts

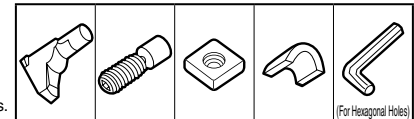

Negative Inserts

Cat. No.	Conventional Cat. No.	Stock		Dimensions (mm)						Applicable Inserts		Lever Pin	Bolt	Shim	Shim Pin	Spanner
		R	L	h	b	L ₁	f	h ₁	L ₂	Cat. No.	Ref. Page					
PCFN R/L2020K12	PCFN R/L2020-43	●	●	20	20	125	25	20	28	CN□□1204	From B21	LCL4	LCS4	LSC42	LSP4	LH030
PCFN R/L2520M12	PCFN R/L2520-43	●	●	25	20	150	25	25	28							
PCFN R/L2525M12	PCFN R/L2525-43	●	●	25	25	150	32	25	28							
PCFN R/L3225P12	PCFN R/L3225-43	●	●	32	25	170	32	32	28	CN□□1906	From B26	LCL6	LCS6	LSC63	LSP6	LH040

Above figures show right hand tools.

Note: When using right/left handed type inserts for facing, holder and insert are opposite handed.

Applicable Inserts ◀ DCLN / PCLN / PCBN / PCFN Type

Recommended Inserts

- Please also refer to the selection guide for inserts. (from page A8)
- Some combinations need to be made-to-order or cannot be manufactured.

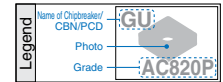

Applications	P (Steel)			M (Stainless Steel)			K (Cast Iron)			N (Non-ferrous)	H (Hardened Steel)	
	Finishing	Medium	Rough Cutting	Finishing	Medium	Rough Cutting	High-Speed/Finishing	Finishing to Medium Cutting	Medium to Rough Cutting	—	Coated	Non-coated
Continuous Cutting	SU T1500Z	GU AC810P	MU AC820P	EF AC610M	EG AC6030M	EM AC6030M	SUMIBORON BN7000	UZ AC405K	GZ AC405K	SUMIDIA DA1000	SUMIBORON BNC2010	SUMIBORON BN1000
General Cutting	SU AC810P	GU AC820P	MU AC820P	EF AC6030M	EG AC6030M	EM AC6040M	SUMIBORON BN7000	GZ AC415K	GZ AC415K	SUMIDIA DA1000	SUMIBORON BNC2020	SUMIBORON BN1000
Interrupted Cutting	SX AC820P	UX AC830P	MX AC830P	EF AC6030M	EG AC6040M	EM AC6040M	SUMIBORON BN7000	GZ AC420K	No Breaker AC420K	SUMIDIA DA1000	SUMIBORON BNC300	SUMIBORON BN350
Recommended Cutting Conditions	From A8			From A18			From A22			From A32	From A28	

DDJN / DDHN / DDNN Type

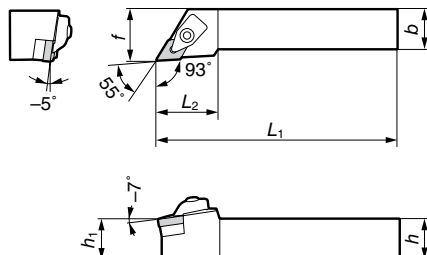
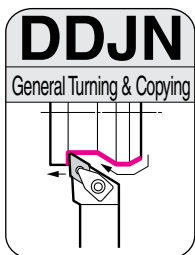
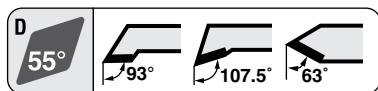

SEC- D Type Tool Holders General Turning and Copying
Double Clamp

■ Holders

Above figures show right hand tools.

Cat. No.	Stock		Dimensions (mm)						Applicable Inserts	
	R	L	h	b	L ₁	f	h ₁	L ₂	Cat. No.	Ref. Page
DDJN R/L2020K15	●	●	20	20	125	25	20	38	DN□□1504	From B31
DDJN R/L2525M15	●	●	25	25	150	32	25	38		
DDJN R/L2525M15E	●	●	25	25	150	32	25	38	DN□□1506	From B34

■ Spare Parts

* Item is sold separately

SCP-2	5.0	DNS1504 DNS1506	BFTX0409N	TRX15 (*)	LH040	LH025

Clamp Set Parts

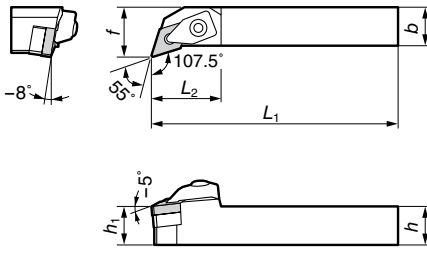
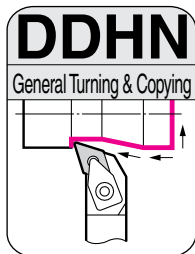

SEC- D Type Tool Holders General Turning and Copying
Double Clamp

■ Holders

Above figures show right hand tools.

Cat. No.	Stock		Dimensions (mm)						Applicable Inserts	
	R	L	h	b	L ₁	f	h ₁	L ₂	Cat. No.	Ref. Page
DDHN R/L2020K15	●	●	20	20	125	25	20	35	DN□□1504	From B31
DDHN R/L2525M15	●	●	25	25	150	32	25	35		

■ Spare Parts

* Item is sold separately

SCP-2	5.0	DNS1504	BFTX0409N	TRX15 (*)	LH040	LH025

Clamp Set Parts

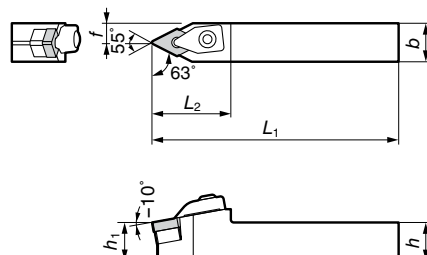
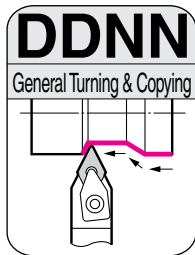

SEC- D Type Tool Holders General Turning and Copying
Double Clamp

■ Holders

Cat. No.	Stock	Dimensions (mm)						Applicable Inserts	
		h	b	L ₁	f	h ₁	L ₂	Cat. No.	Ref. Page
DDNN N2020K15	●	20	20	125	10.5	20	40	DN□□1504	From B31
DDNN N2525M15	●	25	25	150	13.0	25	40		

■ Spare Parts

* Item is sold separately

SCP-2	5.0	DNS1504	BFTX0409N	TRX15 (*)	LH040	LH025

Clamp Set Parts

Applicable Inserts ← DDJN / DDHN / DDNN / PDJN Type

Recommended Inserts

- Please also refer to the selection guide for inserts. (from page A8)
- Some combinations need to be made-to-order or cannot be manufactured.

Applications	P (Steel)			M (Stainless Steel)			K (Cast Iron)			N (Non-ferrous)	H (Hardened Steel)	
	Finishing	Medium	Rough Cutting	Finishing	Medium	Rough Cutting	High-Speed/Finishing	Finishing to Medium Cutting	Medium to Rough Cutting	—	Coated	Non-coated
Continuous Cutting	SU T1500Z	GU AC810P	MU AC820P	EF AC610M	EG AC6030M	EM AC6030M	SUMIBORON BN7000	UZ AC405K	GZ AC405K	SUMIDIA DA1000	SUMIBORON BNC2010	SUMIBORON BN1000
General Cutting	SU AC810P	GU AC820P	MU AC820P	EF AC6030M	EG AC6030M	EM AC6040M	SUMIBORON BN7000	GZ AC415K	GZ AC415K	SUMIDIA DA1000	SUMIBORON BNC2020	SUMIBORON BN2000
Interrupted Cutting	SX AC820P	UX AC830P	MX AC830P	EF AC6030M	EG AC6040M	EM AC6040M	SUMIBORON BN7000	GZ AC420K	No Breaker AC420K	SUMIDIA DA1000	SUMIBORON BNC300	SUMIBORON BN350
Recommended Cutting Conditions	From A8			From A18			From A22			From A32	From A28	

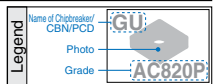

External Holders

Negative Inserts

C

D

R

S

T

V

W

PDJN Type

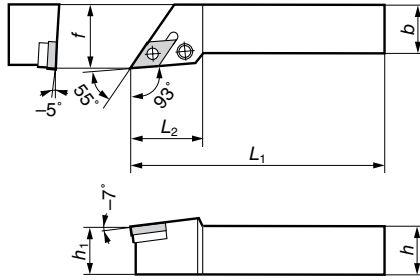
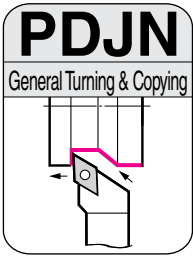

SEC- 70 Type Tool Holders

General Turning and Copying

Lever Lock

■ Spare Parts

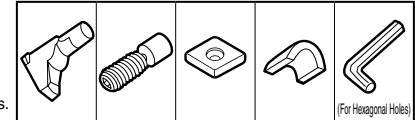

Above figures show right hand tools.

■ Holders

Cat. No.	Conventional Cat. No.	Stock		Dimensions (mm)						Applicable Inserts		Lever Pin	Bolt	Shim	Shim Pin	Spanner
		R	L	h	b	L ₁	f	h ₁	L ₂	Cat. No.	Ref. Page					
PDJN R/L2020K11	PDJN R/L2020-33	●	●	20	20	125	25	20	25	DN□□1104	B30	LCL3	LCS3	LSD317	LSP3	LH025
PDJN R/L2525M11	PDJN R/L2525-33	●	●	25	25	150	32	25	25	DN□□1504	From B31	LCL4	LCS4	LSD42	LSP4	LH030
PDJN R/L2020K1504	PDJN R/L2020-43	●	●	20	20	125	25	20	35							
PDJN R/L2525M1504	PDJN R/L2525-43	●	●	25	25	150	32	25	35							
PDJN R/L3225P1504	PDJN R/L3225-43			32	25	170	32	32	35	DN□□1506	From B34	LCL4	LCS4	LSD42	LSP4	LH030
PDJN R/L3232P1504	PDJN R/L3232-43	●	●	32	32	170	40	32	35							
PDJN R/L2525M1506	PDJN R/L2525-44	●	●	25	25	150	32	25	35	DN□□1506	From B34	LCL4	LCS4	LSD42	LSP4	LH030
PDJN R/L3225P1506	PDJN R/L3225-44			32	25	170	32	32	35							
PDJN R/L3232P1506	PDJN R/L3232-44			32	32	170	40	32	35							

Applicable Inserts ◀ DDJN / DDHN / DDNN / PDJN Type

Recommended Inserts

- Please also refer to the selection guide for inserts. (from page A8)
- Some combinations need to be made-to-order or cannot be manufactured.

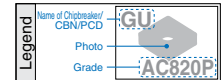

Applications Cutting State	P (Steel)			M (Stainless Steel)			K (Cast Iron)			N (Non-ferrous)	H (Hardened Steel)	
	Finishing	Medium	Rough Cutting	Finishing	Medium	Rough Cutting	High-Speed/Finishing	Finishing to Medium Cutting	Medium to Rough Cutting	—	Coated	Non-coated
Continuous Cutting	SU T1500Z	GU AC810P	MU AC820P	EF AC610M	EG AC6030M	EM AC6030M	SUMIBORON BN7000	UZ AC405K	GZ AC405K	SUMIDIA DA1000	SUMIBORON BNC2010	SUMIBORON BN1000
General Cutting	SU AC810P	GU AC820P	MU AC820P	EF AC6030M	EG AC6030M	EM AC6040M	SUMIBORON BN7000	GZ AC415K	GZ AC415K	SUMIDIA DA1000	SUMIBORON BNC2020	SUMIBORON BN2000
Interrupted Cutting	SX AC820P	UX AC830P	MX AC830P	EF AC6030M	EG AC6040M	EM AC6040M	SUMIBORON BN7000	GZ AC420K	No Breaker AC420K	SUMIDIA DA1000	SUMIBORON BNC300	SUMIBORON BN350
Recommended Cutting Conditions	From A8			From A18			From A22			From A32	From A28	

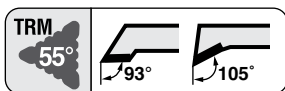

External Copying

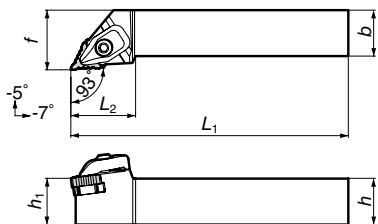
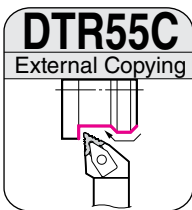

■ Holders

Above figures show right hand tools.

Cat. No.	Stock		Dimensions (mm)					
	R	L	h	b	L ₁	f	h ₁	L ₂
DTR55C R/L2020-K17	●	●	20	20	125	25	20	35
DTR55C R/L2525-M17	●	●	25	25	150	32	25	35

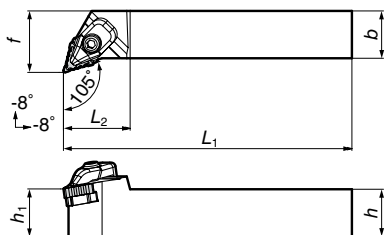

Above figures show right hand tools.

Cat. No.	Stock		Dimensions (mm)					
	R	L	h	b	L ₁	f	h ₁	L ₂
DTR55Q R/L2020-K17	●	●	20	20	125	28.5	20	35
DTR55Q R/L2525-M17	●	●	25	25	150	32.0	25	35

Refer to page E67 for details on the S-DTR55C type for internal copying.

■ Characteristics

- **55° Included Angle**
1.5 times more cutting edges as compared to DNMG inserts!

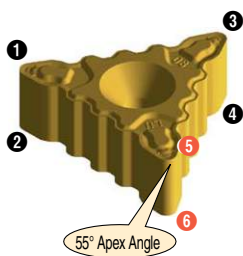

● Extra-Strong Clamping

Extra strong and rigid clamping with unique clamp on lock and serrated insert design.

- Prevents the insert from shifting during copying
- Reliability even in interrupted machining

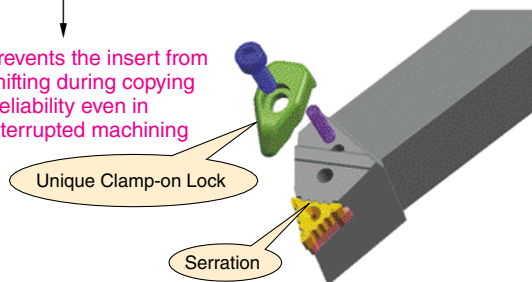

■ Important Note

● Depth of Cut

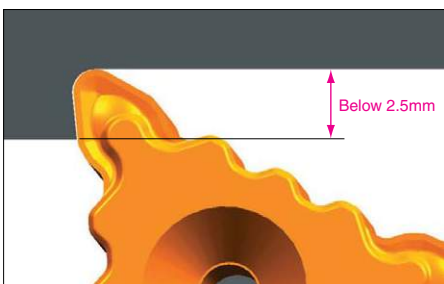

Maximum depth of cut should be 2.5mm

● Cutting Edge Angle

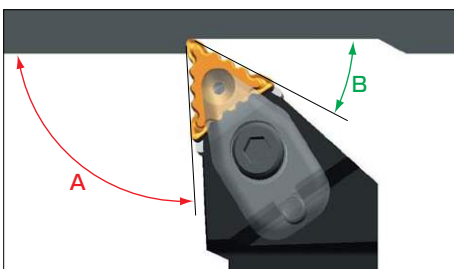

Cat. No.	A	B	Note
DTR55C	93°	27°	Approach angle of major cutting edge is 95.5°.
DTR55Q	105°	15°	Approach angle of major cutting edge is 107.5°.

● Torque

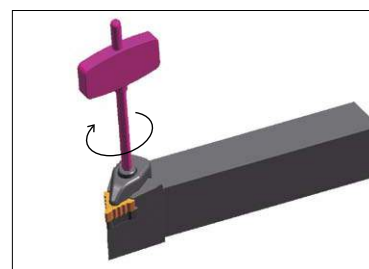

Please use the included special spanner TSW040 (3.5 to 4.5N·m torque is recommended).

SumiTurn T-REX

● T-REX Insert and Holders Identification

Insert

TRM 55 17 08 -GU
 T-REX Angle | Nose Radius | Name of Chipbreaker
 Inserts | Insert Size

External Holder

DTR 55 C R 2525 -M 17
 T-REX Angle | Feed Direction | Shank Length |
 Holders | Approach Angle | Shank Sizes | Insert Size

Note: Approach Angle

C ···· 93° (95.5° for major cutting edge)

Q ···· 105° (107.5° for major cutting edge)

■ Spare Parts (Common)

* Item is sold separately.

			Recommended Tightening Torque (N·m)
TRCP3	S-SP4-20	BX0520	3.5 to 4.5

TRW5505	BFTX0307N	TSW040	TRX10(*)

C External Holders

Negative Inserts

C

D

R

S

T

V

W

Special



■ Insert

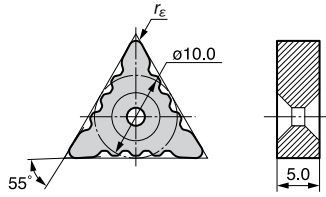

Application P Steel M Stainless Steel

Application	Appearance	Cat. No.	Nose Radius r_n	Coated Carbide						Coated Cermet	
				AC810P	AC820P	AC830P	AC2000	AC610M	AC630M	T3000Z	T2000Z
Fine Finishing	FL	TRM 551704-FL	0.4		●		▲			●	▲
		551708-FL	0.8		●		▲			●	▲
Finishing	LU	TRM 551704-LU	0.4	●	●	●	▲			●	▲
		551708-LU	0.8	●	●	●	▲			●	▲
		551712-LU	1.2	●	●	●	▲			●	▲
Medium	SU	TRM 551704-SU	0.4	●	●		▲	▲	●	●	▲
		551708-SU	0.8	●	●		▲	▲	●	●	▲
		551712-SU	1.2	●	●		▲	▲	●	●	▲
Medium	GU	TRM 551704-GU	0.4	●	●	●	▲		●		
		551708-GU	0.8	●	●	●	▲		●		
		551712-GU	1.2	●	●	●	▲		●		

■ Chipbreaker Application Range

● Main Chipbreakers

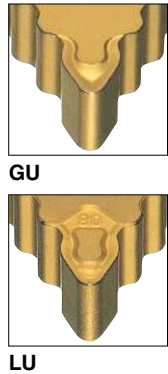
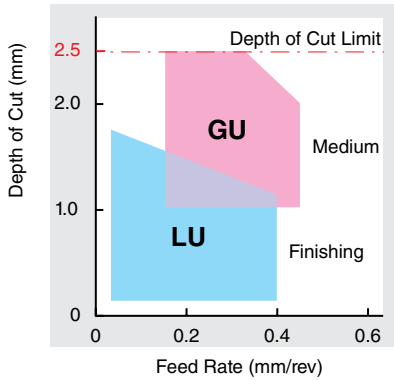

● Finishing Sub-Chipbreakers

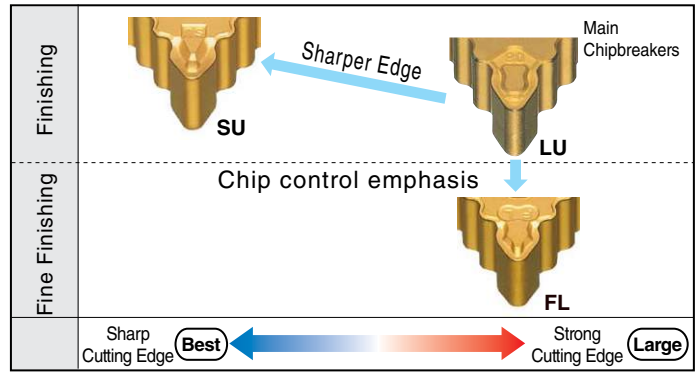

■ Application Range by Grade (The values in the table are recommended cutting speeds. (m/min))

Grades		AC810P	AC820P	AC830P	AC2000	AC610M	AC630M	T3000Z	T2000Z
Grade		Coated Carbide	Coated Carbide	Coated Carbide	Coated Carbide	Coated Carbide	Coated Carbide	Coated Cermet	Coated Cermet
Work Material	P Low Carbon Steel	200 400	150 350	120 300	150 350	180 350	120 300	100 400	100 400
	P General Steel & Alloy Steel	150 300	100 250	80 200	100 250	180 280	80 230	100 250	100 300
	M Stainless Steel			50 150		130 210	100 160		
Applications	Finishing	◎	○	○	○	◎	○	◎	◎
	Medium	○	◎	○	◎	○	◎	○	○
	Interrupted Cutting		○	◎	○		○	○	

◎:Best ○: Good

External Holders

Negative Inserts

C

D

R

S

T

V

W

Special

DSBN / DSDN Type

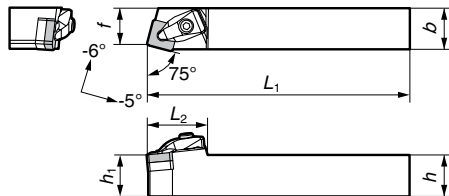
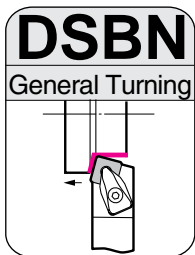
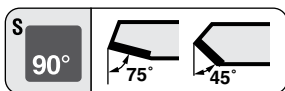

SEC- D Type Tool Holders General Turning and Copying
Double Clamp

■ Holders

Above figures show right hand tools.

Cat. No.	Stock		Dimensions (mm)						Applicable Inserts		Clamp Set	Recommended Tightening Torque (N·m)	Shim	Shim Screw	Shim Spanner	Spanner for Upper Surface	Spanner for Lower Surface
	R	L	h	b	L ₁	f	h ₁	L ₂	Cat. No.	Ref. Page							
DSBN R/L2020K12	●	●	20	20	125	17	20	36	SN□□1204	From B41	SCP-2	5.0	SNS1204	BFTX0409N	TRX15 (*)	LH040	LH025
DSBN R/L2525M12	●	●	25	25	150	22	25	36	SN□□1506	From B44	SCP-3	5.0	SNS1506	BFTX0509N	TRX20 (*)	LH040	LH025
DSBN R/L2525M15	●	●	25	25	150	22	25	36	SN□□1906	From B45	SCP-5	5.0	SNS1906	BFTX0511N	TRX20 (*)	LH040	LH025
DSBN R/L3232P15	●	●	32	32	170	27	32	36	SN□□2507	B47	SCP-6	6.0	SNS2507	BFTX0615N	TRD25 (*)	LH060	—
DSBN R/L3232P19	●	●	32	32	170	27	32	45	SN□□2509	B48	SCP-6	6.0	SNS2509	BFTX0615N	TRD25 (*)	LH060	—
DSBN R/L4040S19	●	●	40	40	250	35	40	45									
DSBN R/L4040S2507	●	●	40	40	250	35	40	58									
DSBN R/L4040S2509	●	●	40	40	250	35	40	58									

Clamp Set Parts

■ Spare Parts

* Item is sold separately

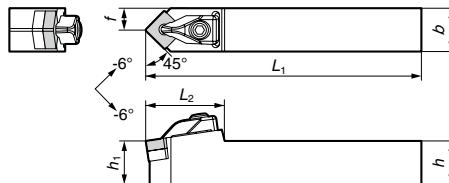
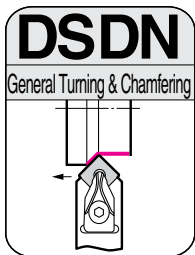
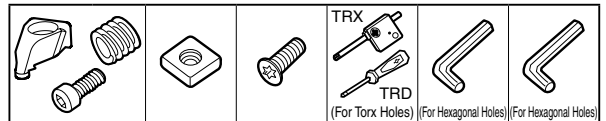

SEC- D Type Tool Holders General Turning and Copying
Double Clamp

■ Holders

Cat. No.	Stock		Dimensions (mm)						Applicable Inserts		Clamp Set	Recommended Tightening Torque (N·m)	Shim	Shim Screw	Shim Spanner	Spanner for Upper Surface	Spanner for Lower Surface
	R	L	h	b	L ₁	f	h ₁	L ₂	Cat. No.	Ref. Page							
DSDN N2020K12	●	●	20	20	125	10.0	20	36	SN□□1204	From B41	SCP-2	5.0	SNS1204	BFTX0409N	TRX15 (*)	LH040	LH025
DSDN N2525M12	●	●	25	25	150	12.5	25	36									

Clamp Set Parts

■ Spare Parts

* Item is sold separately

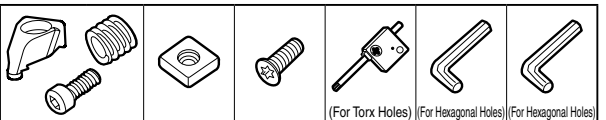

Applicable Inserts ◀ DSBN / DSDN / DSSN / PSSN / PSDN / PSBN / PSKN / ESBN / ESDN / ESKN / ESSN Type

Recommended Inserts

- Please also refer to the selection guide for inserts. (from page A8)
- Some combinations need to be made-to-order or cannot be manufactured.

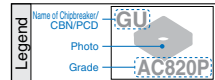

Applications	P (Steel)			M (Stainless Steel)			K (Cast Iron)			H (Hardened Steel)	
	Finishing	Medium	Rough Cutting	Finishing	Medium	Rough Cutting	High-Speed/Finishing	Finishing to Medium Cutting	Medium to Rough Cutting	Coated	Non-coated
Continuous Cutting	SU T1500Z	GU AC810P	MU AC820P	EF AC610M	EG AC6030M	EM AC6030M	SUMIBORON BN7000	UZ AC405K	GZ AC405K	SUMIBORON BNC2010	SUMIBORON BN1000
General Cutting	SU AC810P	GU AC820P	MU AC820P	EF AC6030M	EG AC6030M	EM AC6040M	SUMIBORON BN7000	GZ AC415K	GZ AC415K	SUMIBORON BNC2020	SUMIBORON BN2000
Interrupted Cutting	SX AC820P	UX AC830P	MX AC830P	EF AC6030M	EG AC6040M	EM AC6040M	SUMIBORON BN7000	GZ AC420K	No Breaker AC420K	SUMIBORON BNC300	SUMIBORON BN350
Recommended Cutting Conditions	From A8			From A18			From A22			From A28	

DSSN / PSSN Type

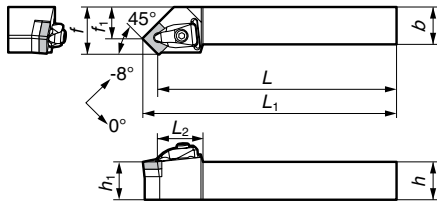
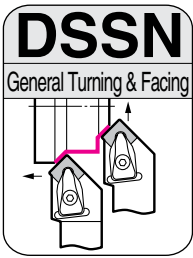
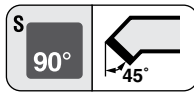

SEC- D Type Tool Holders

General Turning and Copying

Double Clamp

Spare Parts

* Item is sold separately

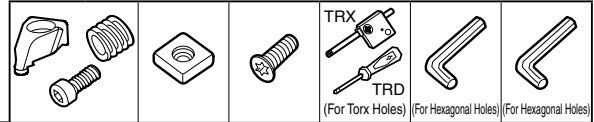

■ Holders

Above figures show right hand tools.

Cat. No.	Stock		Dimensions (mm)								Applicable Inserts		Clamp Set	Recommended Tightening Torque(N·m)	Shim	Shim Screw	Shim Spanner	Spanner for Upper Surface	Spanner for Lower Surface
	R	L	h	b	L ₁	L	f	f ₁	h ₁	L ₂	Cat. No.	Ref. Page							
DSSN R/L2020K12	●	●	20	20	133.3	125	25	16.9	20	30	SN□□1204	From B41	SCP-2	5.0	SNS1204	BFTX0409N	TRX15 (*)	LH040	LH025
DSSN R/L2525M12	●	●	25	25	158.3	150	32	23.9	25	30									
DSSN R/L2525M15	●	●	25	25	160.2	150	32	22.0	25	30	SN□□1506	From B44	SCP-3	5.0	SNS1506	BFTX0509N	TRX20 (*)	LH040	LH025
DSSN R/L3232P15	●	●	32	32	180.2	170	40	30.0	32	30									
DSSN R/L3232P19	●	●	32	32	182.5	170	40	27.8	32	36	SN□□1906	From B45	SCP-5	5.0	SNS1906	BFTX0511N	TRX20 (*)	LH040	LH025
DSSN R/L4040S19	●	●	40	40	262.5	250	50	37.8	40	36									
DSSN R/L4040S2507	●	●	40	40	266.0	250	50	34.3	40	47	SN□□2507	B47	SCP-6	6.0	SNS2507	BFTX0615N	TRD25 (*)	LH060	—
DSSN R/L4040S2509	●	●	40	40	266.0	250	50	34.3	40	47	SN□□2509	B48							

Clamp Set Parts

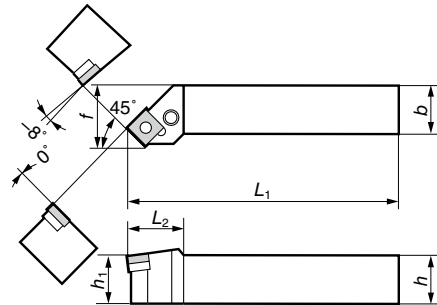
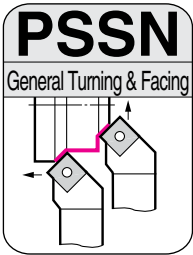

SEC- 70 Type Tool Holders

General Turning and Copying

Lever Lock

■ Spare Parts

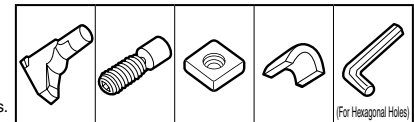

■ Holders

Above figures show right hand tools.

Cat. No.	Conventional Cat. No.	Stock		Dimensions (mm)							Applicable Inserts		Lever Pin	Bolt	Shim	Shim Pin	Spanner
		R	L	h	b	L ₁	f	h ₁	L ₂	Cat. No.	Ref. Page						
PSSN R/L1616H09	PSSN R/L1616-32	●	●	16	16	100	20	16	22	SN□□0903	B40	LCL3	LCS3	LSS32	LSP3	LH025	
PSSN R/L2020K12	PSSN R/L2020-43	●	●	20	20	125	25	20	30								
PSSN R/L2520M12	PSSN R/L2520-43			25	20	150	25	25	30								
PSSN R/L2525M12	PSSN R/L2525-43	●	●	25	25	150	32	25	30	SN□□1204	From B41	LCL4	LCS4	LSS42	LSP4	LH030	
PSSN R/L3225P12	PSSN R/L3225-43			32	25	170	32	32	30								
PSSN R/L3232P12	PSSN R/L3232-43			32	32	170	40	32	30								
PSSN R/L3225P15	PSSN R/L3225-54			32	25	170	32	32	40	SN□□1506	From B44	LCL5	LCS5	LSS53	LSP5	LH030	
PSSN R/L3232P15	PSSN R/L3232-54	●	●	32	32	170	40	32	40								
PSSN R/L3232P19	PSSN R/L3232-64	●	●	32	32	170	40	32	40	SN□□1906	From B45	LCL6	LCS6	LSS63	LSP6	LH040	
PSSN R/L4040R19	PSSN R/L4040-64			40	40	200	50	40	40								

Note: When using right/left handed type inserts for facing, holder and insert are opposite handed.

External Holders

Negative Inserts

C

D

R

S

T

V

W

PSDN / PSBN Type

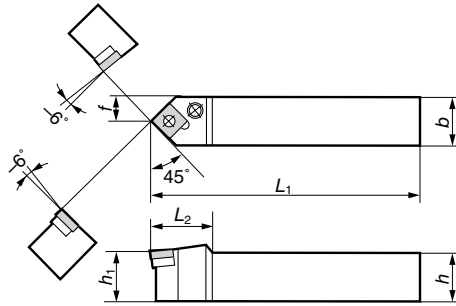
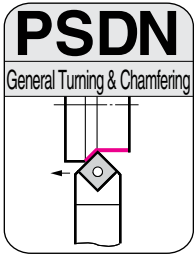
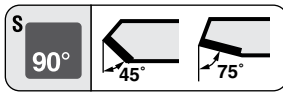

SEC- 70 Type Tool Holders

General Turning and Copying
Lever Lock

■ Holders

Cat. No.	Conventional Cat. No.	Stock	Dimensions (mm)						Applicable Inserts		Lever Pin	Bolt	Shim	Shim Pin	Spanner
			h	b	L ₁	f	h ₁	L ₂	Cat. No.	Ref. Page					
PSDN N1616H09	PSDN N1616-32	●	16	16	100	8.0	16	22	SN□□0903	B40	LCL3	LCS3	LSS32	LSP3	LH025
PSDN N2020K12	PSDN N2020-43	●	20	20	125	10.0	20	30	SN□□1204	From B41	LCL4	LCS4	LSS42	LSP4	LH030
PSDN N2520M12	PSDN N2520-43	●	25	20	150	10.0	25	30							
PSDN N2525M12	PSDN N2525-43	●	25	25	150	12.5	25	30							
PSDN N3225P12	PSDN N3225-43	●	32	25	170	12.5	32	30							
PSDN N3232P12	PSDN N3232-43	●	32	32	170	16.0	32	40	SN□□1506	From B44	LCL5	LCS5	LSS53	LSP5	LH030
PSDN N3225P15	PSDN N3225-54	●	32	25	170	12.5	32	40							
PSDN N3232P15	PSDN N3232-54	●	32	32	170	16.0	32	40	SN□□1906	From B45	LCL6	LCS6	LSS63	LSP6	LH040
PSDN N3232P19	PSDN N3232-64	●	32	32	170	16.0	32	40							
PSDN N4040R19	PSDN N4040-64	●	40	40	200	20.0	40	40							

■ Spare Parts

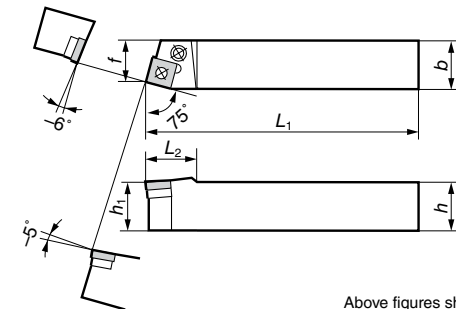
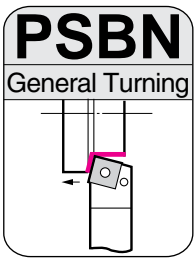
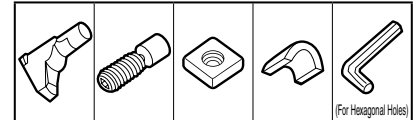

SEC- 70 Type Tool Holders

General Turning and Copying
Lever Lock

■ Holders

Above figures show right hand tools.

Cat. No.	Conventional Cat. No.	Stock		Dimensions (mm)						Applicable Inserts		Lever Pin	Bolt	Shim	Shim Pin	Spanner
		R	L	h	b	L ₁	f	h ₁	L ₂	Cat. No.	Ref. Page					
PSBN R/L1616H09	PSBN R/L1616-32	●	●	16	16	100	13	16	22	SN□□0903	B40	LCL3	LCS3	LSS32	LSP3	LH025
PSBN R/L2020K12	PSBN R/L2020-43	●	●	20	20	125	17	20	28	SN□□1204	From B41	LCL4	LCS4	LSS42	LSP4	LH030
PSBN R/L2520M12	PSBN R/L2520-43	●	●	25	20	150	17	25	28							
PSBN R/L2525M12	PSBN R/L2525-43	●	●	25	25	150	22	25	28							
PSBN R/L3225P12	PSBN R/L3225-43	●	●	32	25	170	22	32	28							
PSBN R/L3232P12	PSBN R/L3232-43	●	●	32	32	170	27	32	35	SN□□1506	From B44	LCL5	LCS5	LSS53	LSP5	LH030
PSBN R/L3225P15	PSBN R/L3225-54	●	●	32	25	170	22	32	35							
PSBN R/L3232P15	PSBN R/L3232-54	●	●	32	32	170	27	32	35	SN□□1906	From B45	LCL6	LCS6	LSS63	LSP6	LH040
PSBN R/L3232P19	PSBN R/L3232-64	●	●	32	32	170	27	32	40							
PSBN R/L4040R19	PSBN R/L4040-64	●	●	40	40	200	35	40	40	SN□□2507	B47	LCL8	LCS8	LSS84	LSP8	LH050
PSBN R/L5050S25	PSBN R/L5050-85	●	●	50	50	250	43	50	50							

■ Spare Parts

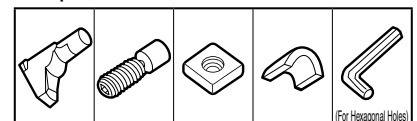

Applicable Inserts ◀ DSBN / DSDN / DSSN / PSSN / PSDN / PSBN / PSKN / ESBN / ESDN / ESKN / ESSN Type

Recommended Inserts

- Please also refer to the selection guide for inserts. (from page A8)
- Some combinations need to be made-to-order or cannot be manufactured.

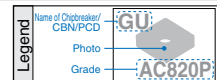

Applications Cutting State	P (Steel)			M (Stainless Steel)			K (Cast Iron)			H (Hardened Steel)	
	Finishing	Medium	Rough Cutting	Finishing	Medium	Rough Cutting	High-Speed/Finishing	Finishing to Medium Cutting	Medium to Rough Cutting	Coated	Non-coated
Continuous Cutting	SU T1500Z	GU AC810P	MU AC820P	EF AC610M	EG AC6030M	EM AC6030M	SUMIBORON BN7000	UZ AC405K	GZ AC405K	SUMIBORON BNC2010	SUMIBORON BN1000
General Cutting	SU AC810P	GU AC820P	MU AC820P	EF AC6030M	EG AC6030M	EM AC6040M	SUMIBORON BN7000	GZ AC415K	GZ AC415K	SUMIBORON BNC2020	SUMIBORON BN2000
Interrupted Cutting	SX AC820P	UX AC830P	MX AC830P	EF AC6030M	EG AC6040M	EM AC6040M	SUMIBORON BN7000	GZ AC420K	No Breaker AC420K	SUMIBORON BNC300	SUMIBORON BN350
Recommended Cutting Conditions	From A8			From A18			From A22			From A28	

C External Holders

Negative Inserts

C

D

R

S

T

V

W

PSKN / ESBN Type

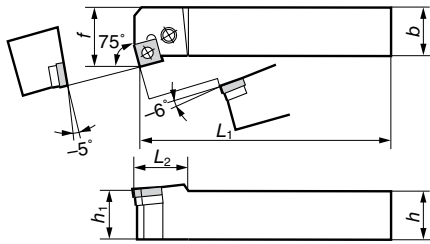
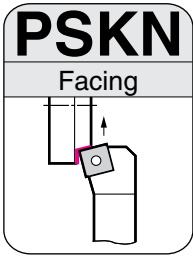

SEC- 70 Type Tool Holders

General Turning and Copying

Lever Lock

■ Spare Parts

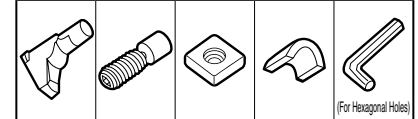

■ Holders

Above figures show right hand tools.

Cat. No.	Conventional Cat. No.	Stock		Dimensions (mm)						Applicable Inserts		Lever Pin	Bolt	Shim	Shim Pin	Spanner
		R	L	h	b	L ₁	f	h ₁	L ₂	Cat. No.	Ref. Page					
PSKN R/L1616H09	PSKN R/L1616-32	●	●	16	16	100	20	16	20	SN□□0903	B40	LCL3	LCS3	LSS32	LSP3	LH025
PSKN R/L2020K12	PSKN R/L2020-43	●	●	20	20	125	25	20	26	SN□□1204	From B41	LCL4	LCS4	LSS42	LSP4	LH030
PSKN R/L2520M12	PSKN R/L2520-43			25	20	150	25	25	26							
PSKN R/L2525M12	PSKN R/L2525-43	●	●	25	25	150	32	25	26							
PSKN R/L3225P12	PSKN R/L3225-43			32	25	170	32	32	26	SN□□1506	From B44	LCL5	LCS5	LSS53	LSP5	LH030
PSKN R/L3232P12	PSKN R/L3232-43			32	32	170	32	32	26							
PSKN R/L3225P15	PSKN R/L3225-54			32	25	170	32	32	32	SN□□1906	From B45	LCL6	LCS6	LSS63	LSP6	LH040
PSKN R/L3232P15	PSKN R/L3232-54			32	32	170	32	32	32							
PSKN R/L3232P19	PSKN R/L3232-64	●	●	32	32	170	40	32	36	SN□□2507	B47	LCL8	LCS8	LSS84	LSP8	LH050
PSKN R/L4040R19	PSKN R/L4040-64			40	40	200	50	40	36							
PSKN R/L5050S25	PSKN R/L5050-85			50	50	250	60	50	44							

Note: When using right/left handed type inserts for facing, holder and insert are opposite handed.

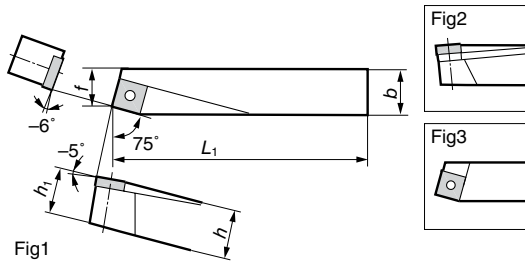
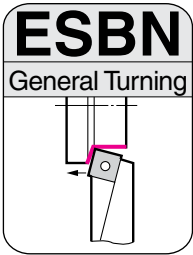

SEC- 30 Type Tool Holders

General Turning and Copying

Pin Lock

■ Spare Parts

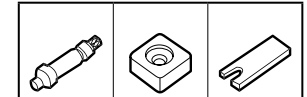

■ Holders

Above figures show right hand tools.

Cat. No.	Conventional Cat. No.	Stock		Dimensions (mm)						Fig	Applicable Inserts		Pin	Shim	Spanner
		R	L	h	b	L ₁	f	h ₁	Cat. No.		Ref. Page				
ESBN R/L1212F09	ESBN R/L1212	●	●	12	12	80	9.5	11.5		1	SN□□0903	B40	P321US	-	KY40
ESBN R/L1616H09	ESBN R/L1616H32			16	16	100	13.0	15.5		1					
ESBN R/L1616H12	ESBN R/L1616H43			16	16	100	13.0	15.5		3	SN□□1204	From B41	P432U	-	
ESBN R/L2020K12	ESBN R/L2020			20	20	125	17.0	19.5		1					
ESBN R/L2020K12W	ESBN R/L2020W	●	●	20	20	125	17.0	19.5		2					
ESBN R/L2520M12	ESBN R/L2520			25	20	150	17.0	24.5		3	SN□□1204	From B41	P433U	-	
ESBN R/L2520M12W	ESBN R/L2520W			25	20	150	17.0	24.5		2					
ESBN R/L2525M12	ESBN R/L2525			25	25	150	22.0	24.5		1	SN□□1204	From B41	P433W	ESS42	
ESBN R/L2525M12W	ESBN R/L2525W	●		25	25	150	22.0	24.5		2					

ESDN / ESKN Type

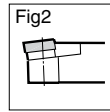
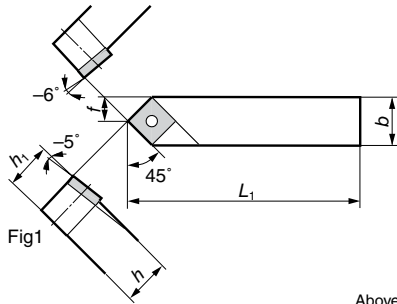
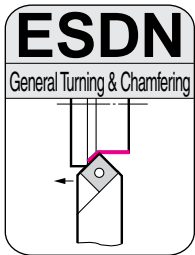
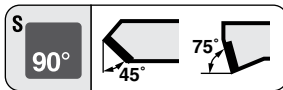

SEC- 30 Type Tool Holders

General Turning and Copying

Pin Lock

■ Holders

Above figures show right hand tools.

Cat. No.	Conventional Cat. No.	Stock		Dimensions (mm)					Fig	Applicable Inserts		Pin	Shim	Spanner
		R	L	h	b	L ₁	f	h ₁		Cat. No.	Ref. Page			
ESDN R/L1212F09	ESDN R/L1212	●	●	12	12	80	6.0	11.5	1	SN□□0903	B40	P321US	-	KY40
ESDN R/L1616H09	ESDN R/L1616H32	●	●	16	16	100	8.0	15.5	1			P322US	-	
ESDN R/L2020K12	ESDN R/L2020			20	20	125	10.0	19.5	1	SN□□1204	From B41	P433U	-	
ESDN R/L2020K12W	ESDN R/L2020W	●	●	20	20	125	10.0	19.5	2			P433W	ESS42	
ESDN R/L2520M12	ESDN R/L2520			25	20	150	10.0	24.5	1			P434U	-	
ESDN R/L2520M12W	ESDN R/L2520W			25	20	150	10.0	24.5	2			P434W	ESS42	
ESDN R/L2525M12	ESDN R/L2525			25	25	150	12.5	24.5	1			P434U	-	
ESDN R/L2525M12W	ESDN R/L2525W	●	●	25	25	150	12.5	24.5	2			P434W	ESS42	

■ Spare Parts

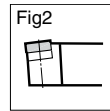
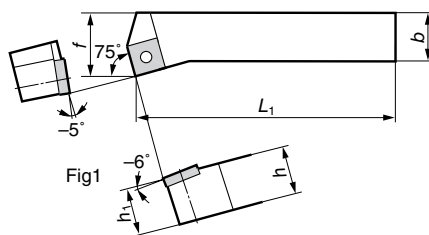
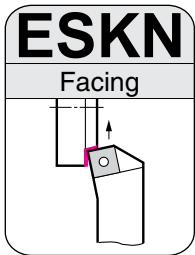
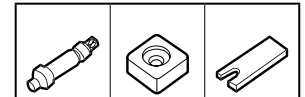

SEC- 30 Type Tool Holders

General Turning and Copying

Pin Lock

■ Holders

Above figures show right hand tools.

Cat. No.	Conventional Cat. No.	Stock		Dimensions (mm)					Fig	Applicable Inserts		Pin	Shim	Spanner
		R	L	h	b	L ₁	f	h ₁		Cat. No.	Ref. Page			
ESKN R/L1212F09	ESKN R/L1212	●	●	12	12	80	16	11.5	1	SN□□0903	B40	P321US	-	KY40
ESKN R/L1616H09	ESKN R/L1616H32	●	●	16	16	100	20	15.5	1			P322US	-	
ESKN R/L1616H12	ESKN R/L1616H43			16	16	100	20	15.5	1	SN□□1204	From B41	P432U	-	
ESKN R/L2020K12	ESKN R/L2020			20	20	125	25	19.5	1			P433U	-	
ESKN R/L2020K12W	ESKN R/L2020W	●	●	20	20	125	25	19.5	2			P433W	ESS42	
ESKN R/L2520M12	ESKN R/L2520			25	20	150	25	24.5	1			P434U	-	
ESKN R/L2520M12W	ESKN R/L2520W			25	20	150	25	24.5	2			P434W	ESS42	
ESKN R/L2525M12	ESKN R/L2525			25	25	150	32	24.5	1			P434U	-	
ESKN R/L2525M12W	ESKN R/L2525W	●	●	25	25	150	32	24.5	2	P434W	ESS42			

■ Spare Parts

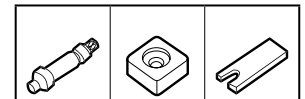

Note: When using right/left handed type inserts for facing, holder and insert are opposite handed.

Applicable Inserts ◀ DSBN / DSDN / DSSN / PSSN / PSDN / PSBN / PSKN / ESBN / ESDN / ESKN / ESSN Type

Recommended Inserts

- Please also refer to the selection guide for inserts. (from page A8)
- Some combinations need to be made-to-order or cannot be manufactured.

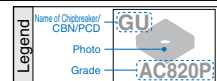

Applications	P (Steel)			M (Stainless Steel)			K (Cast Iron)			H (Hardened Steel)	
	Finishing	Medium	Rough Cutting	Finishing	Medium	Rough Cutting	High-Speed/Finishing	Finishing to Medium Cutting	Medium to Rough Cutting	Coated	Non-coated
Continuous Cutting	SU T1500Z	GU AC810P	MU AC820P	EF AC610M	EG AC6030M	EM AC6030M	SUMIBORON BN7000	UZ AC405K	GZ AC405K	SUMIBORON BNC2010	SUMIBORON BN1000
General Cutting	SU AC810P	GU AC820P	MU AC820P	EF AC6030M	EG AC6030M	EM AC6040M	SUMIBORON BN7000	GZ AC415K	GZ AC415K	SUMIBORON BNC2020	SUMIBORON BN2000
Interrupted Cutting	SX AC820P	UX AC830P	MX AC830P	EF AC6030M	EG AC6040M	EM AC6040M	SUMIBORON BN7000	GZ AC420K	No Breaker AC420K	SUMIBORON BNC300	SUMIBORON BN350
Recommended Cutting Conditions	From A8			From A18			From A22			From A28	

C External Holders

Negative Inserts

C

D

R

S

T

V

W

ESSN Type

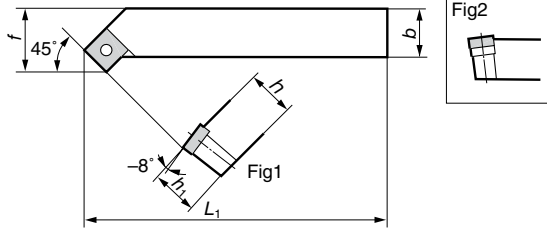
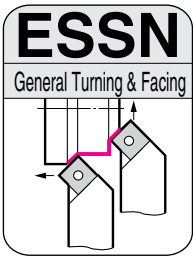
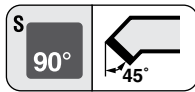

SEC- 30 Type Tool Holders

General Turning

Pin Lock

■ Spare Parts

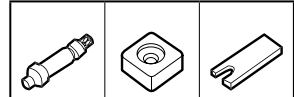

■ Holders

Above figures show right hand tools.

Cat. No.	Conventional Cat. No.	Stock		Dimensions (mm)						Fig	Applicable Inserts		Pin	Shim	Spanner
		R	L	h	b	L ₁	f	h ₁	Cat. No.		Ref. Page				
ESSN R/L1212F09	ESSN R/L1212	●	●	12	12	80	16	11.5		1	SN□□0903	B40	P321US	-	KY40
ESSN R/L1616H09	ESSN R/L1616H32	●	●	16	16	100	20	15.5		1			P322US	-	
ESSN R/L1616H12	ESSN R/L1616H43			16	16	100	20	15.5		1	SN□□1204	From B41	P432U	-	
ESSN R/L2020K12	ESSN R/L2020	●	●	20	20	125	25	19.5		1			P433U	-	
ESSN R/L2020K12W	ESSN R/L2020W	●	●	20	20	125	25	19.5		2			P433W	ESS42	
ESSN R/L2520M12	ESSN R/L2520			25	20	150	25	24.5		1			P434U	-	
ESSN R/L2520M12W	ESSN R/L2520W			25	20	150	25	24.5		2			P434W	ESS42	
ESSN R/L2525M12	ESSN R/L2525			25	25	150	32	24.5		1			P434U	-	
ESSN R/L2525M12W	ESSN R/L2525W	●	●	25	25	150	32	24.5		2			P434W	ESS42	

Note: When using right/left handed type inserts for facing, holder and insert are opposite handed.

Applicable Inserts ◀ DSBN/DSDN/DSSN/PSSN/PSDN/PSBN/PSKN/ESBN/ESDN/ESKN/ESSN Type

Recommended Inserts

- Please also refer to the selection guide for inserts. (from page A8)
- Some combinations need to be made-to-order or cannot be manufactured.

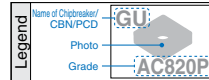

Applications	P (Steel)			M (Stainless Steel)			K (Cast Iron)			H (Hardened Steel)	
	Finishing	Medium	Rough Cutting	Finishing	Medium	Rough Cutting	High-Speed/Finishing	Finishing to Medium Cutting	Medium to Rough Cutting	Coated	Non-coated
Continuous Cutting	SU T1500Z	GU AC810P	MU AC820P	EF AC610M	EG AC6030M	EM AC6030M	SUMIBORON BN7000	UZ AC405K	GZ AC405K	SUMIBORON BNC2010	SUMIBORON BN1000
General Cutting	SU AC810P	GU AC820P	MU AC820P	EF AC6030M	EG AC6030M	EM AC6040M	SUMIBORON BN7000	GZ AC415K	GZ AC415K	SUMIBORON BNC2020	SUMIBORON BN2000
Interrupted Cutting	SX AC820P	UX AC830P	MX AC830P	EF AC6030M	EG AC6040M	EM AC6040M	SUMIBORON BN7000	GZ AC420K	No Breaker AC420K	SUMIBORON BNC300	SUMIBORON BN350
Recommended Cutting Conditions	From A8			From A18			From A22			From A28	

DTGN / DTFN Type

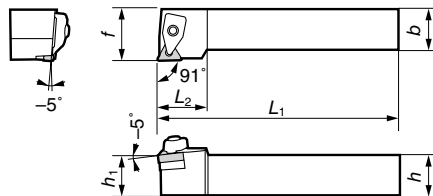
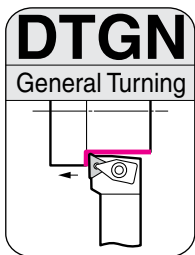
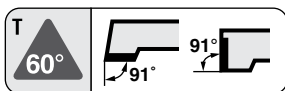

SEC- D Type Tool Holders General Turning and Copying
Double Clamp

■ Holders

Above figures show right hand tools.

Cat. No.	Stock		Dimensions (mm)						Applicable Inserts		Clamp Set	Recommended Tightening Torque (N·m)	Shim	Shim Screw	Shim Spanner	Spanner for Upper Surface	Spanner for Lower Surface
	R	L	h	b	L ₁	f	h ₁	L ₂	Cat. No.	Ref. Page							
DTGN R/L2020K16	●	●	20	20	125	25	20	31	TN□□1604	From B54	SCP-1	5.0	TNS1604	BFTX0307N	TRX10 (*)	LH040	LH025
DTGN R/L2525M16	●	●	25	25	150	32	25	31									

Clamp Set Parts C36

■ Spare Parts

* Item is sold separately.

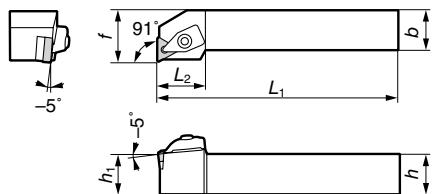
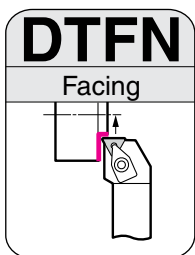
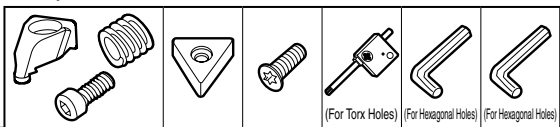

SEC- D Type Tool Holders General Turning and Copying
Double Clamp

■ Holders

Above figures show right hand tools.

Cat. No.	Stock		Dimensions (mm)						Applicable Inserts		Clamp Set	Recommended Tightening Torque (N·m)	Shim	Shim Screw	Shim Spanner	Spanner for Upper Surface	Spanner for Lower Surface
	R	L	h	b	L ₁	f	h ₁	L ₂	Cat. No.	Ref. Page							
DTFN R/L2020K16	●	●	20	20	125	25	20	30	TN□□1604	From B54	SCP-1	5.0	TNS1604	BFTX0307N	TRX10 (*)	LH040	LH025
DTFN R/L2525M16	●	●	25	25	150	32	25	30									

Note: When using right/left handed type inserts for facing, holder and insert are opposite handed.

Clamp Set Parts C36

■ Spare Parts

* Item is sold separately.

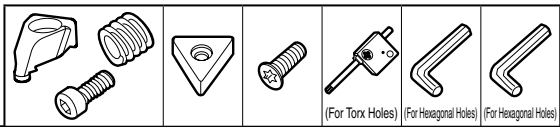

Applicable Inserts ← DTGN/DTFN/PTGN/PTTN/PTFN/ETGN/ETAN/ETFN/ETEN/ETXN/MTJN/MTXN Type

Recommended Inserts

- Please also refer to the selection guide for inserts. (from page A8)
- Some combinations need to be made-to-order or cannot be manufactured.

Applications	P (Steel)			M (Stainless Steel)			K (Cast Iron)			N (Non-ferrous)	H (Hardened Steel)	
	Finishing	Medium	Rough Cutting	Finishing	Medium	Rough Cutting	High-Speed/Finishing	Finishing to Medium Cutting	Medium to Rough Cutting	—	Coated	Non-coated
Continuous Cutting	SU T1500Z	GU AC810P	MU AC820P	EF AC610M	EG AC6030M	EM AC6030M	SUMIBORON BN7000	UZ AC405K	GZ AC405K	SUMIDIA DA1000	SUMIBORON BNC2010	SUMIBORON BN1000
General Cutting	SU AC810P	GU AC820P	MU AC820P	EF AC6030M	EG AC6030M	EM AC6040M	SUMIBORON BN7000	GZ AC415K	GZ AC415K	SUMIDIA DA1000	SUMIBORON BNC2020	SUMIBORON BN2000
Interrupted Cutting	SX AC820P	UX AC830P	MX AC830P	EF AC6030M	EG AC6040M	EM AC6040M	SUMIBORON BN7000	GZ AC420K	No Breaker	SUMIDIA DA1000	SUMIBORON BNC300	SUMIBORON BN350
Recommended Cutting Conditions	From A8			From A18			From A22			From A32	From A28	

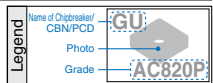

PTGN / PTTN Type

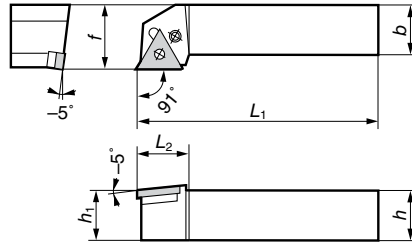
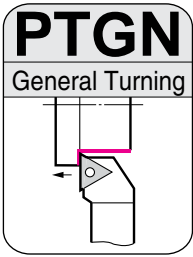
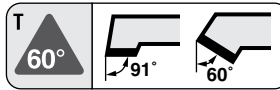

SEC- 70 Type Tool Holders

General Turning and Copying

Lever Lock

■ Spare Parts

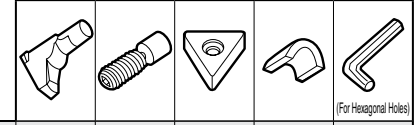

■ Holders

Above figures show right hand tools.

Cat. No.	Conventional Cat. No.	Stock		Dimensions (mm)						Applicable Inserts		Lever Pin	Bolt	Shim	Shim Pin	Spanner
		R	L	h	b	L ₁	f	h ₁	L ₂	Cat. No.	Ref. Page					
PTGN R/L1616H16	PTGN R/L1616-33	●	●	16	16	100	20	16	20	TN□□1604	From B54	LCL3	LCS3	LST317	LSP3	LH025
PTGN R/L2020K16	PTGN R/L2020-33	●	●	20	20	125	25	20	20							
PTGN R/L2520M16	PTGN R/L2520-33			25	20	150	25	25	20							
PTGN R/L2525M16	PTGN R/L2525-33	●	●	25	25	150	32	25	20							
PTGN R/L3225P16	PTGN R/L3225-33			32	25	170	32	32	20							
PTGN R/L2525M22	PTGN R/L2525-43	●	●	25	25	150	32	25	28	TN□□2204	B59	LCL4	LCS4	LST42	LSP4	LH030
PTGN R/L3225P22	PTGN R/L3225-43			32	25	170	32	32	28							
PTGN R/L3232P22	PTGN R/L3232-43			32	32	170	40	32	28							
PTGN R/L3232P27	PTGN R/L3232-54			32	32	170	40	32	33							
PTGN R/L4040R27	PTGN R/L4040-54			40	40	200	50	40	33							

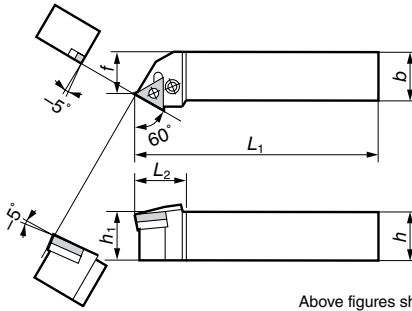
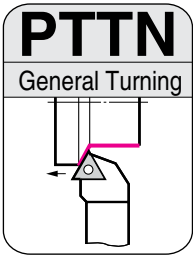

SEC- 70 Type Tool Holders

General Turning and Copying

Lever Lock

■ Spare Parts

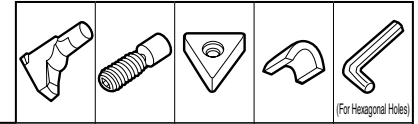

■ Holders

Above figures show right hand tools.

Cat. No.	Conventional Cat. No.	Stock		Dimensions (mm)						Applicable Inserts		Lever Pin	Bolt	Shim	Shim Pin	Spanner
		R	L	h	b	L ₁	f	h ₁	L ₂	Cat. No.	Ref. Page					
PTTN R/L1616H16	PTTN R/L1616-33	●	●	16	16	100	13	16	25	TN□□1604	From B54	LCL3	LCS3	LST317	LSP3	LH025
PTTN R/L2020K16	PTTN R/L2020-33	●	●	20	20	125	17	20	25							
PTTN R/L2520M16	PTTN R/L2520-33			25	20	150	17	25	25							
PTTN R/L2525M16	PTTN R/L2525-33	●	●	25	25	150	22	25	25							
PTTN R/L3225P16	PTTN R/L3225-33			32	25	170	22	32	25							
PTTN R/L2525M22	PTTN R/L2525-43			25	25	150	22	25	25	TN□□2204	B59	LCL4	LCS4	LST42	LSP4	LH030
PTTN R/L3225P22	PTTN R/L3225-43			32	25	170	22	32	25							

External Holders

Negative Inserts

C

D

R

S

T

V

W

PTFN Type

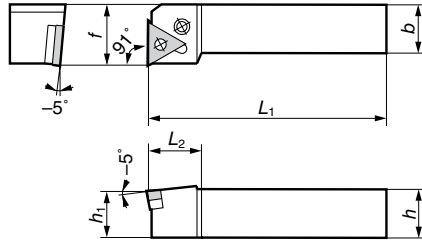
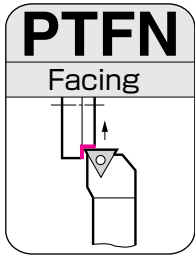
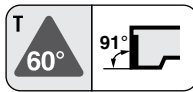

SEC- 70 Type Tool Holders

General Turning and Copying
Lever Lock

Spare Parts

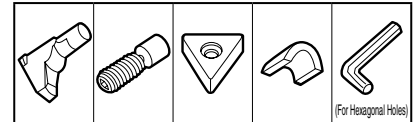

Holdings

Above figures show right hand tools.

Cat. No.	Conventional Cat. No.	Stock		Dimensions (mm)						Applicable Inserts		Lever Pin	Bolt	Shim	Shim Pin	Spanner
		R	L	h	b	L ₁	f	h ₁	L ₂	Cat. No.	Ref. Page					
PTFN R/L1616H16	PTFN R/L1616-33	●	●	16	16	100	20	16	20	TN□□1604	From B54	LCL3	LCS3	LST317	LSP3	LH025
PTFN R/L2020K16	PTFN R/L2020-33	●	●	20	20	125	25	20	20							
PTFN R/L2520M16	PTFN R/L2520-33			25	20	150	25	25	20							
PTFN R/L2525M16	PTFN R/L2525-33	●	●	25	25	150	32	25	20							
PTFN R/L3225P16	PTFN R/L3225-33			32	25	170	32	32	20	TN□□2204	B59	LCL4	LCS4	LST42	LSP4	LH030
PTFN R/L2525M22	PTFN R/L2525-43	●	●	25	25	150	32	25	25							
PTFN R/L3225P22	PTFN R/L3225-43			32	25	170	32	32	25	TN□□2706	B61	LCL5	LCS5	LST53	LSP5	LH030
PTFN R/L3232P22	PTFN R/L3232-43	●	●	32	32	170	40	32	25							
PTFN R/L3232P27	PTFN R/L3232-54			32	32	170	40	32	34							
PTFN R/L4040R27	PTFN R/L4040-54			40	40	200	50	40	34							

Note: When using right/left handed type inserts for facing, holder and insert are opposite handed.

Applicable Inserts ← DTGN/DTFN/PTGN/PTTN/PTFN/ETGN/ETAN/ETFN/ETEN/ETXN/MTJN/MTXN Type

Recommended Inserts

- Please also refer to the selection guide for inserts. (from page A8)
- Some combinations need to be made-to-order or cannot be manufactured.

Applications	P (Steel)			M (Stainless Steel)			K (Cast Iron)			N (Non-ferrous)	H (Hardened Steel)	
	Finishing	Medium	Rough Cutting	Finishing	Medium	Rough Cutting	High-Speed/Finishing	Finishing to Medium Cutting	Medium to Rough Cutting	—	Coated	Non-coated
Continuous Cutting	SU T1500Z	GU AC810P	MU AC820P	EF AC610M	EG AC6030M	EM AC6030M	SUMIBORON BN7000	UZ AC405K	GZ AC405K	SUMIDIA DA1000	SUMIBORON BNC2010	SUMIBORON BN1000
General Cutting	SU AC810P	GU AC820P	MU AC820P	EF AC6030M	EG AC6030M	EM AC6040M	SUMIBORON BN7000	GZ AC415K	GZ AC415K	SUMIDIA DA1000	SUMIBORON BNC2020	SUMIBORON BN2000
Interrupted Cutting	SX AC820P	UX AC830P	MX AC830P	EF AC6030M	EG AC6040M	EM AC6040M	SUMIBORON BN7000	GZ AC420K	No Breaker AC420K	SUMIDIA DA1000	SUMIBORON BNC300	SUMIBORON BN350
Recommended Cutting Conditions	👉 From A8			👉 From A18			👉 From A22			👉 From A32	👉 From A28	

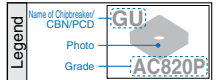

C

External Holders

Negative Inserts

C

D

R

S

T

V

W

ETGN / ETAN Type

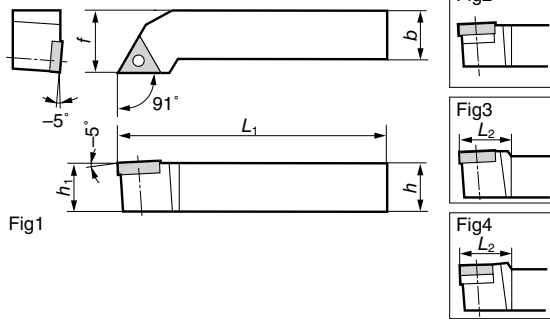
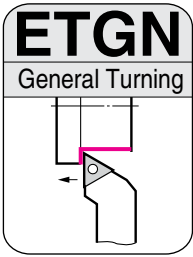
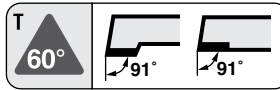

SEC- 30 Type Tool Holders General Turning
Pin Lock

Spare Parts

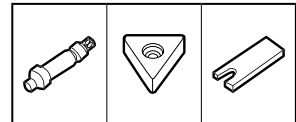

External Holders

Above figures show right hand tools.

Cat. No.	Conventional Cat. No.	Stock		Dimensions (mm)						Fig	Applicable Inserts		Pin	Shim	Spanner
		R	L	h	b	L ₁	f	h ₁	L ₂		Cat. No.	Ref. Page			
ETGN R/L1212F11	ETGN R/L1212	●	●	12	12	80	16	11.5	-	1	TN□□1103	B52	P221US	-	KY25
ETGN R/L1616H1603	ETGN R/L1616H32	●	●	16	16	100	20	15.5	-	1	TN□□1603	B53	P322US	-	KY40
ETGN R/L1616H1604	ETGN R/L1616H33	●	●	16	16	100	20	15.5	-	1	TN□□1604	From B54	P332US	-	
ETGN R/L2020K1603	ETGN R/L2020K32			20	20	125	25	19.5	-	1	TN□□1603	B53	P323US	-	
ETGN R/L2020K1603W	ETGN R/L2020K32W			20	20	125	25	19.5	-	2			P323WS	EST32	
ETGN R/L2020K1604	ETGN R/L2020K33	●	●	20	20	125	25	19.5	-	1	TN□□1604	From B54	P333US	-	
ETGN R/L2020K1604W	ETGN R/L2020K33W	●	●	20	20	125	25	19.5	-	2			P333WS	EST32	
ETGN R/L2520M1604	ETGN R/L2520			25	20	150	25	24.5	-	1			P334US	-	
ETGN R/L2520M1604W	ETGN R/L2520W			25	20	150	25	24.5	-	2			P334WS	EST32	
ETGN R/L2525M1604	ETGN R/L2525M33			25	25	150	32	24.5	-	1			P334US	-	
ETGN R/L2525M1604W	ETGN R/L2525M33W	●	●	25	25	150	32	24.5	-	2			P334WS	EST32	
ETGN R/L2525M22	ETGN R/L2525M43			25	25	150	32	24.5	30	3	TN□□2204	B59	P434U	-	
ETGN R/L2525M22W	ETGN R/L2525M43W	●	●	25	25	150	32	24.5	30	4			P434W	EST43	

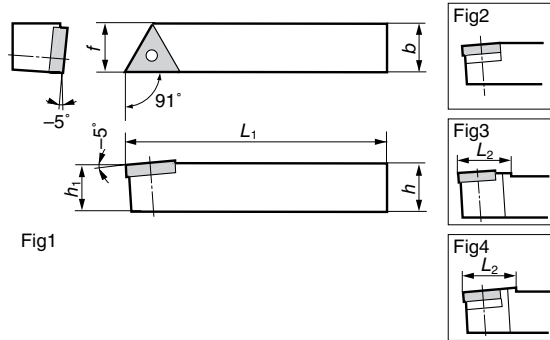
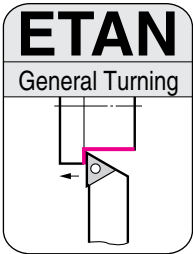

SEC- 30 Type Tool Holders General Turning
Pin Lock

Spare Parts

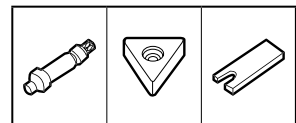

Negative Inserts

Above figures show right hand tools.

Cat. No.	Conventional Cat. No.	Stock		Dimensions (mm)						Fig	Applicable Inserts		Pin	Shim	Spanner
		R	L	h	b	L ₁	f	h ₁	L ₂		Cat. No.	Ref. Page			
ETAN R/L1212F11	ETAN R/L1212	●	●	12	12	80	12	11.5	-	1	TN□□1103	B52	P221US	-	KY25
ETAN R/L1616H1603	ETAN R/L1616H32			16	16	100	16	15.5	-	1	TN□□1603	B53	P322US	-	KY40
ETAN R/L1616H1604	ETAN R/L1616H33	●	●	16	16	100	16	15.5	-	1	TN□□1604	From B54	P332US	-	
ETAN R/L2020K1603	ETAN R/L2020K32			20	20	125	20	19.5	-	1	TN□□1603	B53	P323US	-	
ETAN R/L2020K1603W	ETAN R/L2020K32W			20	20	125	20	19.5	-	2			P323WS	EST32	
ETAN R/L2020K1604	ETAN R/L2020K33			20	20	125	20	19.5	-	1	TN□□1604	From B54	P333US	-	
ETAN R/L2020K1604W	ETAN R/L2020K33W	●	●	20	20	125	20	19.5	-	2			P333WS	EST32	
ETAN R/L2520M1604	ETAN R/L2520			25	20	150	20	24.5	-	1			P334US	-	
ETAN R/L2520M1604W	ETAN R/L2520W			25	20	150	20	24.5	-	2			P334WS	EST32	
ETAN R/L2525M1604	ETAN R/L2525M33			25	25	150	25	24.5	-	1			P334US	-	
ETAN R/L2525M1604W	ETAN R/L2525M33W	●	●	25	25	150	25	24.5	-	2			P334WS	EST32	
ETAN R/L2525M22	ETAN R/L2525M43			25	25	150	25	24.5	30	3	TN□□2204	B59	P434U	-	
ETAN R/L2525M22W	ETAN R/L2525M43W	●	●	25	25	150	25	24.5	30	4			P434W	EST43	

SEC-External Holders ETFN Type

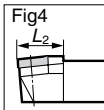
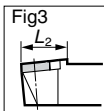
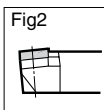
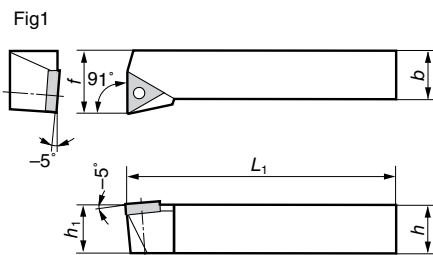
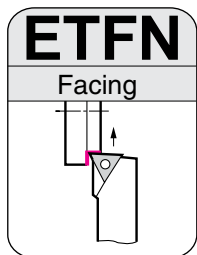
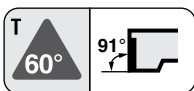

SEC- 30 Type Tool Holders General Turning
Pin Lock

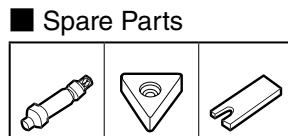

■ Holders

Above figures show right hand tools.

Cat. No.	Conventional Cat. No.	Stock		Dimensions (mm)							Fig	Applicable Inserts		Pin	Shim	Spanner
		R	L	h	b	L ₁	f	h ₁	L ₂	Cat. No.		Ref. Page				
ETFN R/L1212F11	ETFN R/L1212	●	●	12	12	80	16	11.5	-	1	TN□□1103	B52	P221US	-	KY25	
ETFN R/L1616H1603	ETFN R/L1616H32			16	16	100	20	15.5	-	1	TN□□1603	B53	P322US	-		
ETFN R/L1616H1604	ETFN R/L1616H33	●	●	16	16	100	20	15.5	-	1	TN□□1604	From B54	P332US	-		
ETFN R/L2020K1603	ETFN R/L2020K32			20	20	125	25	19.5	-	1	TN□□1603	B53	P323US	-		
ETFN R/L2020K1603W	ETFN R/L2020K32W			20	20	125	25	19.5	-	2			P323WS	EST32		
ETFN R/L2020K1604	ETFN R/L2020K33			20	20	125	25	19.5	-	1			P333US	-		
ETFN R/L2020K1604W	ETFN R/L2020K33W	●	●	20	20	125	25	19.5	-	2			P333WS	EST32	KY40	
ETFN R/L2520M1604	ETFN R/L2520			25	20	150	25	24.5	-	1	TN□□1604	From B54	P334US	-		
ETFN R/L2520M1604W	ETFN R/L2520W			25	20	150	25	24.5	-	2			P334WS	EST32		
ETFN R/L2525M1604	ETFN R/L2525M33			25	25	150	32	24.5	-	1			P334US	-		
ETFN R/L2525M1604W	ETFN R/L2525M33W	●	●	25	25	150	32	24.5	-	2			P334WS	EST32		
ETFN R/L2525M22	ETFN R/L2525M43			25	25	150	32	24.5	30	3	TN□□2204	B59	P434U	-		
ETFN R/L2525M22W	ETFN R/L2525M43W	●	●	25	25	150	32	24.5	30	4			P434W	EST43		

Note: When using right/left handed type inserts for facing, holder and insert are opposite handed.

Applicable Inserts ← DTGN/DTFN/PTGN/PTTN/PTFN/ETGN/ETAN/ETFN/ETEN/ETXN/MTJN/MTXN Type

Recommended Inserts

- Please also refer to the selection guide for inserts. (from page A8)
- Some combinations need to be made-to-order or cannot be manufactured.

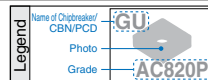

Applications	P (Steel)			M (Stainless Steel)			K (Cast Iron)			N (Non-ferrous)	H (Hardened Steel)	
	Finishing	Medium	Rough Cutting	Finishing	Medium	Rough Cutting	High-Speed/ Finishing	Finishing to Medium Cutting	Medium to Rough Cutting	—	Coated	Non-coated
Continuous Cutting	SU T1500Z	GU AC810P	MU AC820P	EF AC610M	EG AC6030M	EM AC6030M	SUMIBORON BN7000	UZ AC405K	GZ AC405K	SUMIDIA DA1000	SUMIBORON BNC2010	SUMIBORON BN1000
General Cutting	SU AC810P	GU AC820P	MU AC820P	EF AC6030M	EG AC6030M	EM AC6040M	SUMIBORON BN7000	GZ AC415K	GZ AC415K	SUMIDIA DA1000	SUMIBORON BNC2020	SUMIBORON BN2000
Interrupted Cutting	SX AC820P	UX AC830P	MX AC830P	EF AC6030M	EG AC6040M	EM AC6040M	SUMIBORON BN7000	GZ AC420K	No Breaker AC420K	SUMIDIA DA1000	SUMIBORON BNC300	SUMIBORON BN350
Recommended Cutting Conditions	From A8			From A18			From A22			From A32	From A28	

C External Holders
 Negative Inserts
 C
 D
 R
 S
 T
 V
 W

ETEN / ETXN Type

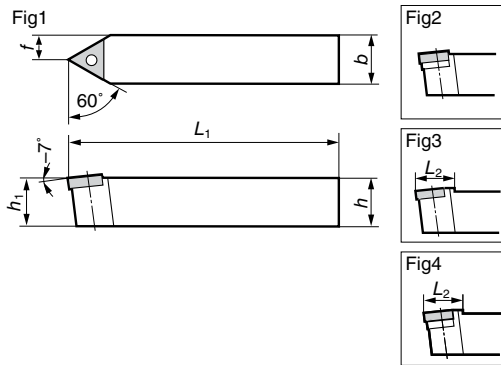
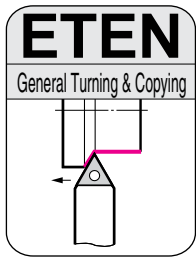
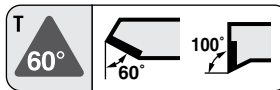

SEC- 30 Type Tool Holders

General Turning
Pin Lock

■ Spare Parts

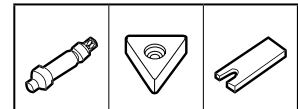

■ Holders

Cat. No.	Conventional Cat. No.	Stock	Dimensions (mm)							Fig	Applicable Inserts		Pin	Shim	Spanner
			h	b	L ₁	f	h ₁	L ₂	Cat. No.		Ref. Page				
ETEN N1212F11	ETEN N1212	●	12	12	80	6.0	11.5	-	1	TN□□1103	B52	P221US	-	KY25	
ETEN N1616H1603	ETEN N1616H32	●	16	16	100	8.0	15.5	-	1	TN□□1603	B53	P322US	-	KY40	
ETEN N1616H1604	ETEN N1616H33	●	16	16	100	8.0	15.5	-	1	TN□□1604	From B54	P332US	-		
ETEN N2020K1603	ETEN N2020K32	●	20	20	125	10.0	19.5	-	1	TN□□1603	B53	P323US	-		
ETEN N2020K1603W	ETEN N2020K32W	●	20	20	125	10.0	19.5	-	2	TN□□1603	B53	P323WS	EST32		
ETEN N2020K1604	ETEN N2020K33	●	20	20	125	10.0	19.5	-	1	TN□□1604	From B54	P333US	-		
ETEN N2020K1604W	ETEN N2020K33W	●	20	20	125	10.0	19.5	-	2			P333WS	EST32		
ETEN N2520M1604	ETEN N2520	●	25	20	150	10.0	24.5	-	1			P334US	-		
ETEN N2520M1604W	ETEN N2520W	●	25	20	150	10.0	24.5	-	2			P334WS	EST32		
ETEN N2525M1604	ETEN N2525M33	●	25	25	150	12.5	24.5	-	1	TN□□1604	From B54	P334US	-		
ETEN N2525M1604W	ETEN N2525M33W	●	25	25	150	12.5	24.5	-	2	TN□□1604	From B54	P334WS	EST32		
ETEN N2525M22	ETEN N2525M43	●	25	25	150	12.5	24.5	30	3	TN□□2204	B59	P434U	-		
ETEN N2525M22W	ETEN N2525M43W	●	25	25	150	12.5	24.5	30	4	TN□□2204	B59	P434W	EST43		

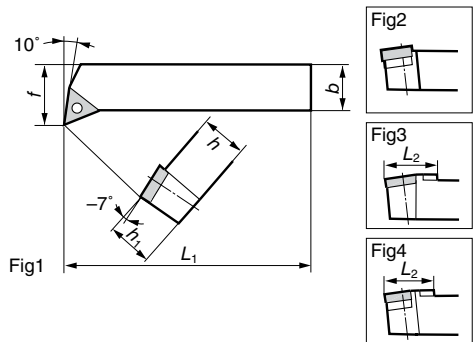
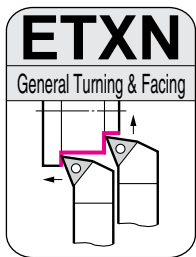

SEC- 30 Type Tool Holders

General Turning
Pin Lock

■ Spare Parts

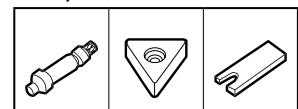

■ Holders

Above figures show right hand tools.

Cat. No.	Conventional Cat. No.	Stock		Dimensions (mm)							Fig	Applicable Inserts		Pin	Shim	Spanner
		R	L	h	b	L ₁	f	h ₁	L ₂	Cat. No.		Ref. Page				
ETXN R/L1212F11	ETXN R/L1212	●	●	12	12	80	16	11.5	-	1	TN□□1103	B52	P221US	-	KY25	
ETXN R/L1616H1603	ETXN R/L1616H32	●	●	16	16	100	20	15.5	-	1	TN□□1603	B53	P322US	-	KY40	
ETXN R/L1616H1604	ETXN R/L1616H33	●	●	16	16	100	20	15.5	-	1	TN□□1604	From B54	P332US	-		
ETXN R/L2020K1603	ETXN R/L2020K32	●	●	20	20	125	25	19.5	-	1	TN□□1603	B53	P323US	-		
ETXN R/L2020K1603W	ETXN R/L2020K32W	●	●	20	20	125	25	19.5	-	2	TN□□1603	B53	P323WS	EST32		
ETXN R/L2020K1604	ETXN R/L2020K33	●	●	20	20	125	25	19.5	-	1	TN□□1604	From B54	P333US	-		
ETXN R/L2020K1604W	ETXN R/L2020K33W	●	●	20	20	125	25	19.5	-	2			P333WS	EST32		
ETXN R/L2520M1604	ETXN R/L2520	●	●	25	20	150	25	24.5	-	1			P334US	-		
ETXN R/L2520M1604W	ETXN R/L2520W	●	●	25	20	150	25	24.5	-	2			P334WS	EST32		
ETXN R/L2525M1604	ETXN R/L2525M33	●	●	25	25	150	32	24.5	-	1	TN□□1604	From B54	P334US	-		
ETXN R/L2525M1604W	ETXN R/L2525M33W	●	●	25	25	150	32	24.5	-	2	TN□□1604	From B54	P334WS	EST32		
ETXN R/L2525M22	ETXN R/L2525M43	●	●	25	25	150	32	24.5	30	3	TN□□2204	B59	P434U	-		
ETXN R/L2525M22W	ETXN R/L2525M43W	●	●	25	25	150	32	24.5	30	4	TN□□2204	B59	P434W	EST43		

Note: When using right/left handed type inserts for facing, holder and insert are opposite handed.

MTJN / MTXN Type

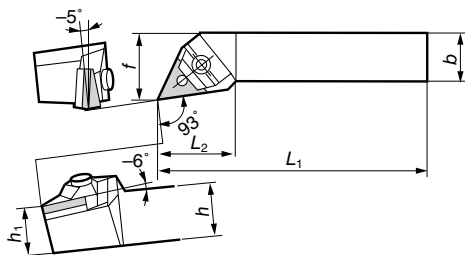
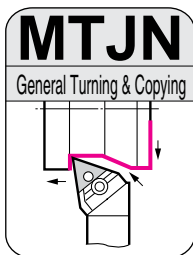
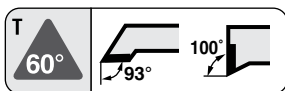

SEC- M Type Tool Holders

General Turning and Copying
Top Clamp + Pin Lock

Spare Parts

Clamp	Pin	Shim	Bolt	Recommended Tightening Torque (N·m)	Nut	Ring	Screw Spanner	Nut Spanner
MMW30	MP317S MP320S MP320S	STW323	BHA0525	4.0	CPM32N	ER04	LH030	LH030
MMW40	MP420 MP420	STW434	BHA0625	4.5	CPM43N	ER05	LH040	LH030

Holders

Above figures show right hand tools.

Cat. No.	Conventional Cat. No.	Stock		Dimensions (mm)						Applicable Inserts		Clamp	Pin	Shim	Bolt	Recommended Tightening Torque (N·m)	Nut	Ring	Screw Spanner	Nut Spanner
		R	L	h	b	L ₁	f	h ₁	L ₂	Cat. No.	Ref. Page									
* MTJN R/L2020K16	MTJN R/L2020-33	●	●	20	20	125	25	20	32	TN□□1604	From B54	MMW30	MP317S MP320S MP320S	STW323	BHA0525	4.0	CPM32N	ER04	LH030	LH030
** MTJN R/L2520M16	MTJN R/L2520-33	●	●	25	20	150	25	25	32	TN□□1604	From B54	MMW30	MP317S MP320S MP320S	STW323	BHA0525	4.0	CPM32N	ER04	LH030	LH030
** MTJN R/L2525M16	MTJN R/L2525-33	●	●	25	25	150	32	25	32	TN□□1604	From B54	MMW30	MP317S MP320S MP320S	STW323	BHA0525	4.0	CPM32N	ER04	LH030	LH030
MTJN R/L2525M22	MTJN R/L2525-43	●	●	25	25	150	32	25	38	TN□□2204	B59	MMW40	MP420 MP420	STW434	BHA0625	4.5	CPM43N	ER05	LH040	LH030
MTJN R/L3225P22	MTJN R/L3225-43	●	●	32	25	170	32	32	38	TN□□2204	B59	MMW40	MP420 MP420	STW434	BHA0625	4.5	CPM43N	ER05	LH040	LH030

When using CIS standard inserts, Pin for holders marked * is MP317 and for holders marked ** is MP320.

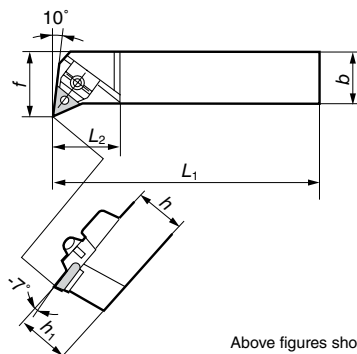
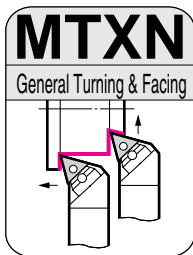

SEC- M Type Tool Holders

General Turning and Copying
Top Clamp + Pin Lock

Spare Parts

Clamp	Pin	Shim	Bolt	Recommended Tightening Torque (N·m)	Nut	Ring	Screw Spanner	Nut Spanner
MMW30	MP317S MP320S	STW323	BHA0525	4.0	CPM32N	ER04	LH030	LH030
MMW40	MP420	STW434	BHA0625	4.5	CPM43N	ER05	LH040	LH030

Holders

Above figures show right hand tools.

Cat. No.	Conventional Cat. No.	Stock		Dimensions (mm)						Applicable Inserts		Clamp	Pin	Shim	Bolt	Recommended Tightening Torque (N·m)	Nut	Ring	Screw Spanner	Nut Spanner
		R	L	h	b	L ₁	f	h ₁	L ₂	Cat. No.	Ref. Page									
* MTXN R/L2020K16	MTXN R/L2020-33	●	●	20	20	125	25	20	32	TN□□1604	From B54	MMW30	MP317S MP320S	STW323	BHA0525	4.0	CPM32N	ER04	LH030	LH030
** MTXN R/L2525M16	MTXN R/L2525-33	●	●	25	25	150	32	25	32	TN□□1604	From B54	MMW30	MP317S MP320S	STW323	BHA0525	4.0	CPM32N	ER04	LH030	LH030
MTXN R/L2525M22	MTXN R/L2525-43	●	●	25	25	150	32	25	38	TN□□2204	B59	MMW40	MP420	STW434	BHA0625	4.5	CPM43N	ER05	LH040	LH030

When using CIS standard inserts, Pin for holders marked * is MP317 and for holders marked ** is MP320.

Note: When using right/left handed type inserts for facing, holder and insert are opposite handed.

Applicable Inserts ← DTGN/DTFN/PTGN/PTTN/PTFN/ETGN/ETAN/ETFN/ETEN/ETXN/MTJN/MTXN Type

Recommended Inserts

- Please also refer to the selection guide for inserts. (from page A8)
- Some combinations need to be made-to-order or cannot be manufactured.

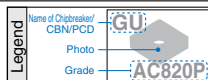

Applications	P (Steel)			M (Stainless Steel)			K (Cast Iron)			N (Non-ferrous)	H (Hardened Steel)	
	Finishing	Medium	Rough Cutting	Finishing	Medium	Rough Cutting	High-Speed / Finishing	Finishing to Medium Cutting	Medium to Rough Cutting	—	Coated	Non-coated
Continuous Cutting	SU	GU	MU	EF	EG	EM	SUMIBORON	UZ	GZ	SUMIDIA	SUMIBORON	SUMIBORON
General Cutting	T1500Z	AC810P	AC820P	AC610M	AC6030M	AC6030M	BN7000	AC405K	AC405K	DA1000	BNC2010	BN1000
		AC810P	AC820P	AC820P	AC6030M	AC6030M	AC6040M	BN7000	AC415K	AC415K	DA1000	BNC2020
Interrupted Cutting	SX	UX	MX	EF	EG	EM	SUMIBORON	GZ	No Breaker	SUMIDIA	SUMIBORON	SUMIBORON
Recommended Cutting Conditions	From A8			From A18			From A22			From A32	From A28	

DVJN / DVVN / DVQN Type

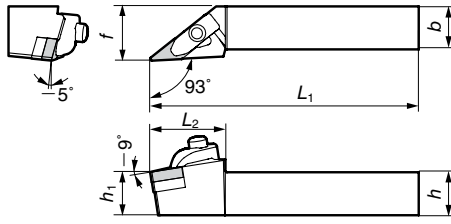
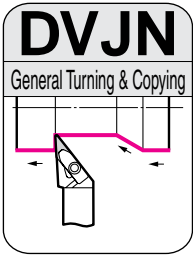
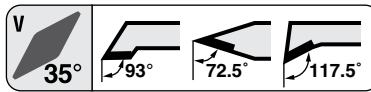

■ Holders

Above figures show right hand tools.

Cat. No.	Stock		Dimensions (mm)						Applicable Inserts	
	R	L	h	b	L ₁	f	h ₁	L ₂	Cat. No.	Ref. Page
DVJN R/L2020K16	●	●	20	20	125	25	20	35	VN□□1604	From B64
DVJN R/L2525M16	●	●	25	25	150	32	25	35		

SEC- D Type Tool Holders

General Turning and Copying

Double Clamp

■ Spare Parts

* Item is sold separately.

SCP-4	5.0	VNS1604	BFTX0307N	TRX10 (*)	LH040	LH025

Clamp Set Parts

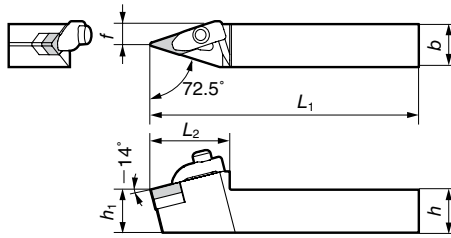
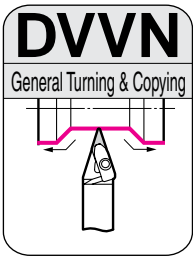

■ Holders

Cat. No.	Stock		Dimensions (mm)						Applicable Inserts	
	R	L	h	b	L ₁	f	h ₁	L ₂	Cat. No.	Ref. Page
DVVN N2020K16	●	●	20	20	125	10.0	20	37	VN□□1604	From B64
DVVN N2525M16	●	●	25	25	150	12.5	25	37		

SEC- D Type Tool Holders

General Turning and Copying

Double Clamp

■ Spare Parts

* Item is sold separately.

SCP-4	5.0	VNS1604	BFTX0307N	TRX10 (*)	LH040	LH025

Clamp Set Parts

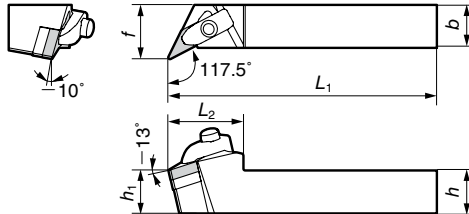
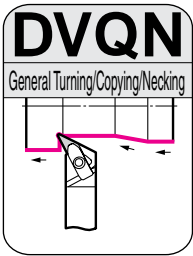

■ Holders

Above figures show right hand tools.

Cat. No.	Stock		Dimensions (mm)						Applicable Inserts	
	R	L	h	b	L ₁	f	h ₁	L ₂	Cat. No.	Ref. Page
DVQN R/L2020K16	●	●	20	20	125	25	20	35	VN□□1604	From B64
DVQN R/L2525M16	●	●	25	25	150	32	25	35		

SEC- D Type Tool Holders

General Turning and Copying

Double Clamp

■ Spare Parts

* Item is sold separately.

SCP-4	5.0	VNS1604	BFTX0307N	TRX10 (*)	LH040	LH025

Clamp Set Parts

Applicable Inserts ◀ DVJN/DVVN/DVQN Type

Recommended Inserts

- Please also refer to the selection guide for inserts. (from page A8)
- Some combinations need to be made-to-order or cannot be manufactured.

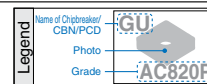

Applications	P (Steel)		M (Stainless Steel)		K (Cast Iron)		N (Non-ferrous)	H (Hardened Steel)	
	Finishing	Medium	Finishing	Medium	High-Speed/Finishing	Finishing to Medium Cutting	—	Coated	Non-coated
Continuous Cutting	SU T1500Z	GU AC810P	EF AC610M	EG AC6030M	SUMIBORON BN700	UZ AC405K	SUMIDIA DA1000	SUMIBORON BNC2010	SUMIBORON BN1000
General Cutting	SU AC810P	GU AC820P	EF AC6030M	EG AC6030M	SUMIBORON BN700	GZ AC415K	SUMIDIA DA1000	SUMIBORON BNC2020	SUMIBORON BN2000
Interrupted Cutting	SX AC820P	UX AC830P	EF AC6030M	EG AC6040M	SUMIBORON BN700	GZ AC420K	SUMIDIA DA1000	SUMIBORON BNC300	SUMIBORON BN350
Recommended Cutting Conditions	From A8		From A18		From A22		From A32	From A28	

DWLN / PWLN / MWLN Type

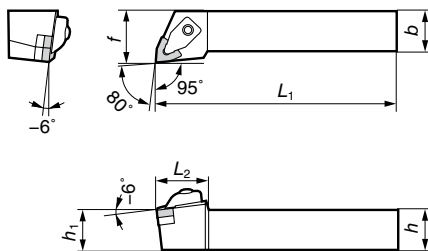
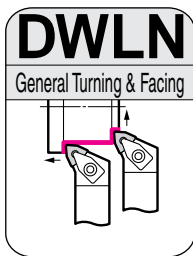
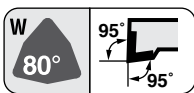

SEC- D Type Tool Holders

General Turning and Copying
Double Clamp

■ Holders

Above figures show right hand tools.

Cat. No.	Stock		Dimensions (mm)						Applicable Inserts	
	R	L	h	b	L ₁	f	h ₁	L ₂	Cat. No.	Ref. Page
DWLN R/L2020K08	●	●	20	20	125	25	20	32	WN□□0804	From B68
DWLN R/L2525M08	●	●	25	25	150	32	25	32		

Note: When using right/left handed type inserts for facing, holder and insert are opposite handed.

Clamp Set Parts **C36**

■ Spare Parts

* Item is sold separately.

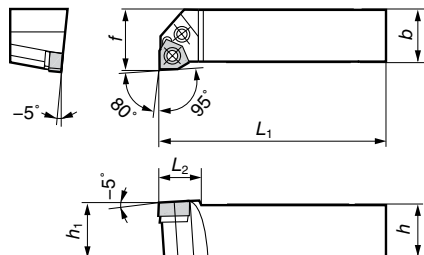
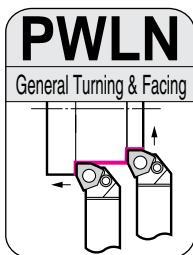
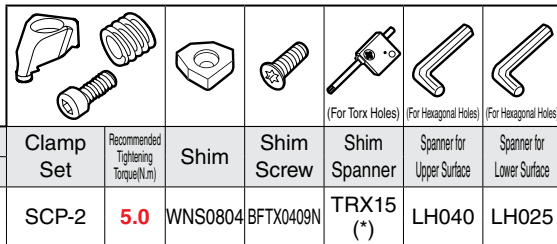

SEC- 70 Type Tool Holders

General Turning and Copying
Lever Lock

■ Holders

Above figures show right hand tools.

Cat. No.	Conventional Cat. No.	Stock		Dimensions (mm)						Applicable Inserts		Lever Pin	Bolt	Shim	Shim Pin	Spanner
		R	L	h	b	L ₁	f	h ₁	L ₂	Cat. No.	Ref. Page					
PWLN R/L2020K06	PWLN R/L2020-33	●	●	20	20	125	25	20	17	WN□□0604	B67	LCL3	LCS3	LSW317	LSP3	LH025
PWLN R/L2525M06	PWLN R/L2525-33	●	●	25	25	150	32	25	17							

Note: When using right/left handed type inserts for facing, holder and insert are opposite handed.

■ Spare Parts

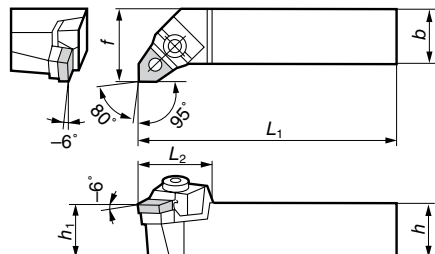
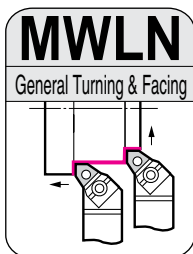
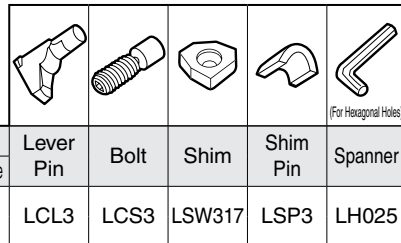

SEC- M Type Tool Holders

General Turning and Copying
Top Clamp + Pin Lock

■ Holders

Above figures show right hand tools.

Cat. No.	Conventional Cat. No.	Stock		Dimensions (mm)						Applicable Inserts	
		R	L	h	b	L ₁	f	h ₁	L ₂	Cat. No.	Ref. Page
MWLN R/L2020K08	MWLN R/L2020-43	●	●	20	20	125	25	20	32	WN□□0804	From B68
MWLN R/L2525M08	MWLN R/L2525-43	●	●	25	25	150	32	25	32		
MWLN R/L3225P08	MWLN R/L3225-43	●	●	32	25	170	32	32	32		

Note: When using right/left handed type inserts for facing, holder and insert are opposite handed.

■ Spare Parts

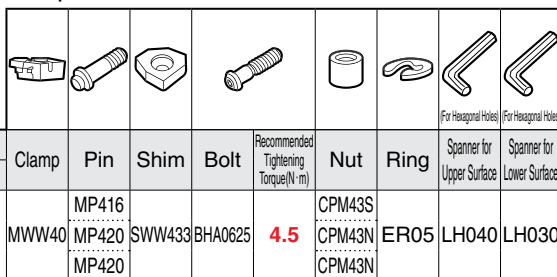

Applicable Inserts ← DWLN / PWLN / MWLN Type

Recommended Inserts

- Please also refer to the selection guide for inserts. (from page A8)
- Some combinations need to be made-to-order or cannot be manufactured.

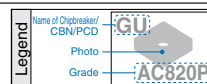

Applications	P (Steel)			M (Stainless Steel)			K (Cast Iron)			H (Hardened Steel)	
	Finishing	Medium	Rough Cutting	Finishing	Medium	Rough Cutting	High-Speed Finishing	Finishing to Medium Cutting	Medium to Rough Cutting	Coated	Non-coated
Continuous Cutting	SU T1500Z	GU AC810P	MU AC820P	EF AC610M	EG AC6030M	EM AC6030M	SUMIBORON BN7000	UZ AC405K	GZ AC405K	SUMIBORON BNC2010	SUMIBORON BN1000
General Cutting	SU AC810P	GU AC820P	MU AC820P	EF AC6030M	EG AC6030M	EM AC6040M	SUMIBORON BN7000	GZ AC415K	GZ AC415K	SUMIBORON BNC2020	SUMIBORON BN2000
Interrupted Cutting	SX AC820P	UX AC830P	MX AC830P	EF AC6030M	EG AC6040M	EM AC6040M	SUMIBORON BN7000	GZ AC420K	No Breaker AC420K	SUMIBORON BNC300*	SUMIBORON BN350
Recommended Cutting Conditions	From A8			From A18			From A22			From A28	

* Made-to-order item

PRGC / PRDC Type

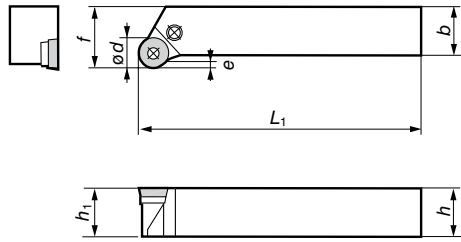
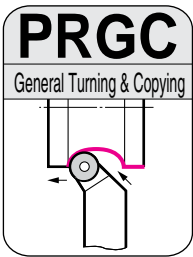

SEC- 70 Type Tool Holders

General Turning and Copying

Lever Lock

Spare Parts

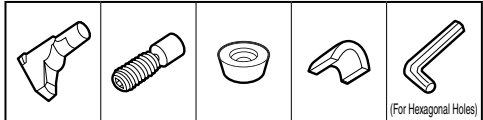

External Holders

Above figures show right hand tools.

Cat. No.	Stock		Dimensions (mm)							Applicable Inserts		Lever Pin	Bolt	Shim	Shim Pin	Spanner
	R	L	h	b	L ₁	f	h ₁	e	od	Cat. No.	Ref. Page					
PRGC R/L2020K10	●	●	20	20	125	25	20	1.5	10	RCM□1003M0	B91	LCL10	LCS10	LSR10	LSP10	LH020
PRGC R/L2525M10	●	●	25	25	150	32	25	1.5	10							
PRGC R/L2020K12	●	●	20	20	125	25	20	2.5	12							
PRGC R/L2525M12	●	●	25	25	150	32	25	2.5	12	RCM□1204M0	B91	LCL12	LCS12	LSR12	LSP10	LH025
PRGC R/L3225P12	●	●	32	25	170	32	32	2.5	12							
PRGC R/L2525M16			25	25	150	32	25	3.0	16	RCM□1606M0	B91	LCL16	LCS16	LSR16	LSP16	LH025
PRGC R/L3225P16			32	25	170	32	32	3.0	16							
PRGC R/L3232P20			32	32	170	40	32	4.0	20	RCM□2006M0	B91	LCL20	LCS20	LSR20	LSP20	LH030
PRGC R/L4040S25			40	40	250	50	40	4.5	25							
PRGC R/L5050T32			50	50	300	63	50	5.5	32	RCM□3209M0	B91	LCL32	LCS32	LSR32	LSP32	LH050

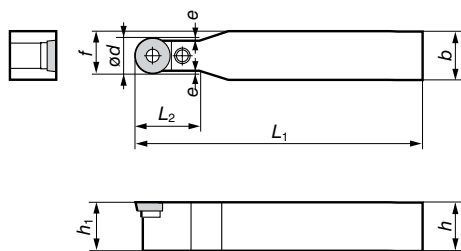
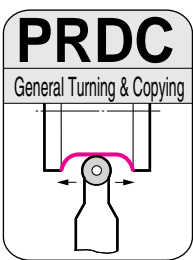

SEC- 70 Type Tool Holders

General Turning and Copying

Lever Lock

Spare Parts

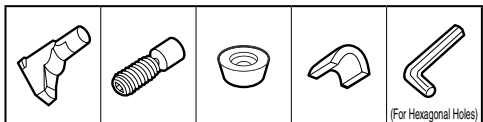

Positive Inserts

Cat. No.	Stock	Dimensions (mm)							Applicable Inserts		Lever Pin	Bolt	Shim	Shim Pin	Spanner	
		h	b	L ₁	f	h ₁	L ₂	e	od	Cat. No.						Ref. Page
PRDC N2020M10	●	20	20	150	15.0	20	22	1.0	10	RCM□1003M0	B91	LCL10	LCS10	LSR10	LSP10	LH020
PRDC N2525M10	●	25	25	150	17.5	25	22	1.0	10							
PRDC N2525M12	●	25	25	150	18.5	25	24	1.2	12							
PRDC N3225Q12	●	32	25	180	18.5	32	24	1.2	12	RCM□1204M0	B91	LCL12	LCS12	LSR12	LSP10	LH025
PRDC N3225Q16	●	32	25	180	20.5	32	28	1.5	16							
PRDC N3232Q20	●	32	32	180	26.0	32	32	1.7	20	RCM□1606M0	B91	LCL16	LCS16	LSR16	LSP16	LH025
										RCM□2006M0	B91	LCL20	LCS20	LSR20	LSP20	LH030
PRDC N4040T25		40	40	300	32.5	40	42	2.0	25	RCM□2507M0	B91	LCL25	LCS25	LSR25	LSP25	LH040
PRDC N5050U32		50	50	350	41.0	50	52	2.5	32	RCM□3209M0	B91	LCL32	LCS32	LSR32	LSP32	LH050



SEC-External Holders SCLC / SDJC / SVJC Type

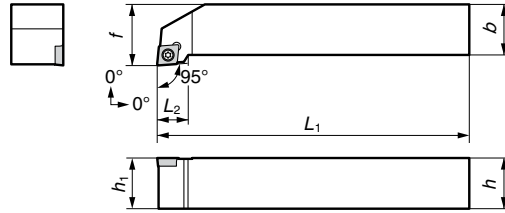
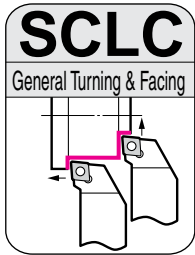

SEC- SC Type Tool Holders

General Turning and Face Grooving

Screw-on



■ Spare Parts

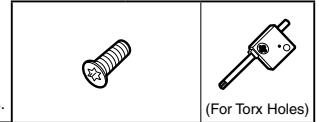

■ Holders

Above figures show right hand tools.

Cat. No.	Conventional Cat. No.	Stock		Dimensions (mm)						Applicable Inserts		Screw	Recommended Tightening Torque(N.m)	Spanner
		R	L	h	b	L ₁	f	h ₁	L ₂	Cat. No.	Ref. Page			
SCLC R/L0808H06	SCLC R/L0808-06	●	●	8	8	100	10	8	-	CC□□0602	From B72	BFTX02506N	1.5	TRX08
SCLC R/L1010H06	SCLC R/L1010-06	●	●	10	10	100	12	10	15	CC□□09T3	From B75	BFTX0409N	3.4	TRX15
SCLC R/L1212H09	SCLC R/L1212-09	●	●	12	12	100	16	12	15					
SCLC R/L1616H09	SCLC R/L1616-09	●	●	16	16	100	20	16	15					
SCLC R/L2020K09	SCLC R/L2020-09	●	●	20	20	125	24	20	15					
SCLC R/L2525M09	SCLC R/L2525M09	●	●	25	25	150	30	25	15					

Note: When using right/left handed type inserts for facing, holder and insert are opposite handed.

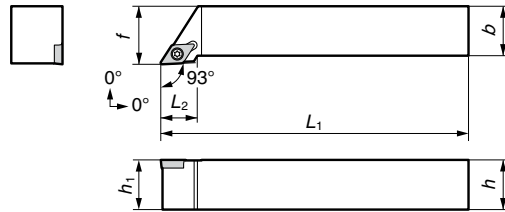
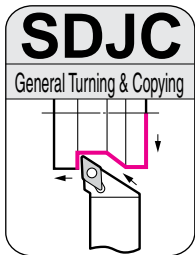

SEC- SD Type Copying Tool Holders

General Turning and Copying

Screw-on



■ Spare Parts

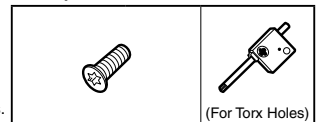

■ Holders

Above figures show right hand tools.

Cat. No.	Conventional Cat. No.	Stock		Dimensions (mm)						Applicable Inserts		Screw	Recommended Tightening Torque(N.m)	Spanner
		R	L	h	b	L ₁	f	h ₁	L ₂	Cat. No.	Ref. Page			
SDJC R/L0808H07	SDJC R/L0808-07	●		8	8	100	10	8	15	DC□□0702	From B82	BFTX02506N	1.5	TRX08
SDJC R/L1010H07	SDJC R/L1010-07	●	●	10	10	100	12	10	18					
SDJC R/L1212H11	SDJC R/L1212-11	●	●	12	12	100	16	12	18	DC□□11T3	From B85	BFTX0409N	3.4	TRX15
SDJC R/L1616H11	SDJC R/L1616-11	●	●	16	16	100	20	16	18					
SDJC R/L2020K11	SDJC R/L2020-11	●	●	20	20	125	24	20	18					
SDJC R/L2525M11	SDJC R/L2525M11	●	●	25	25	150	29	25	18					

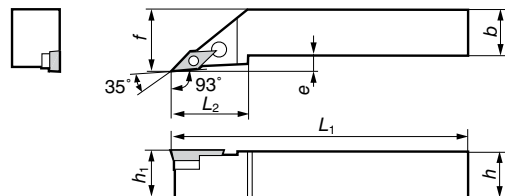
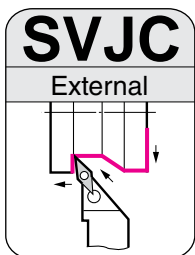

SEC- SV Type Copying Tool Holders

External Copying

Screw-on

■ Spare Parts

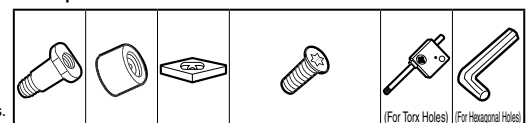

■ Holders

Above figures show right hand tools.

Cat. No.	Conventional Cat. No.	Stock		Dimensions (mm)						Applicable Inserts		Pin	Nut	Shim	Screw	Recommended Tightening Torque(N.m)	Spanner	Nut Spanner	
		R	L	h	b	L ₁	f	h ₁	L ₂	e	Cat. No.								Ref. Page
SVJC R/L2020K16	SVJC R/L2020-33	●	●	20	20	125	25	20	41	5	VC□□1604	B118	VP20	CPV33N	SVP32	BFTX03508	2.0	TRX10	LH025
SVJC R/L2525M16	SVJC R/L2525-33	●	●	25	25	150	32	25	41	7									
SVJC R/L3225P16	SVJC R/L3225-33	●	●	32	25	170	32	32	41	7									

C

External Holders

Positive Inserts

C

D

R

S

T

V

W

SVLC / SVVC / SVPC Type

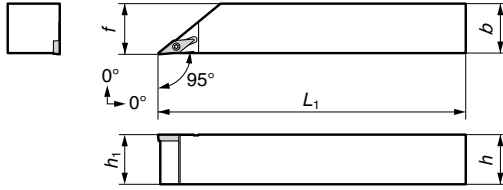
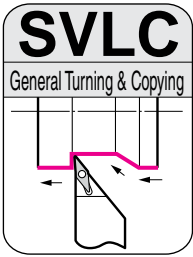
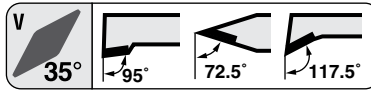

SEC- SV Type MINI Tool Holders

General Turning and Copying
Screw-on

Spare Parts

Screw	Spanner (For Torx Holes)
VC□□1103	From B119
BFTX2508NV	1.5
	TRX08

■ Holders

Above figures show right hand tools.

Cat. No.	Stock		Dimensions (mm)					Applicable Inserts	
	R	L	h	b	L ₁	f	h ₁	Cat. No.	Ref. Page
SVLC R/L1010-H11	●	●	10	10	100	10.5	10	VC□□1103	From B119
SVLC R/L1212-H11	●	●	12	12	100	12.5	12		
SVLC R/L1616-H11	●	●	16	16	100	16.5	16		
SVLC R/L2020-K11*	●	●	20	20	125	20.5	20		
SVLC R/L2525-M11	●	●	25	25	150	25.5	25		

* Previous Cat. No. SVLC R/L 2020-H11

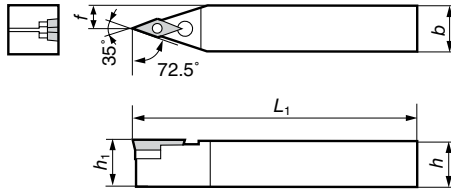
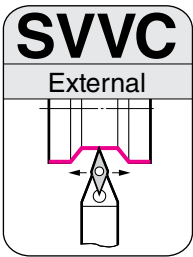

SEC- SV Type Copying Tool Holders

Necking
Screw-on

■ Spare Parts

Pin	Nut	Shim	Screw	Spanner (For Torx Holes)	Nut Spanner (For Hexagonal Holes)
VP20	CPV33N	SVP32	BFTX03508	2.0	TRX10
VP25					
VP32					

■ Holders

Cat. No.	Conventional Cat. No.	Stock		Dimensions (mm)					Applicable Inserts	
		R	L	h	b	L ₁	f	h ₁	Cat. No.	Ref. Page
SVVC N2020K16	SVVC N2020-33	●	●	20	20	125	10.0	20	VC□□1604	From B120
SVVC N2525M16	SVVC N2525-33	●	●	25	25	150	12.5	25		
SVVC N3225P16	SVVC N3225-33	●	●	32	25	170	12.5	32		

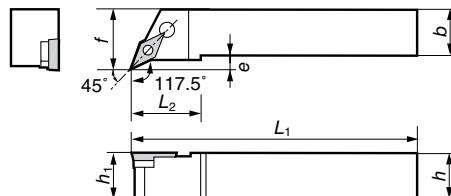
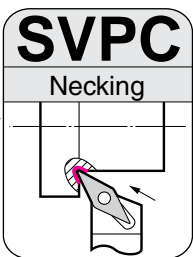

SEC- SV Type Copying Tool Holders

Necking
Screw-on

■ Spare Parts

Pin	Nut	Shim	Screw	Spanner (For Torx Holes)	Nut Spanner (For Hexagonal Holes)
—	—	—	BFTX2508NV	1.5	TRX08
VP20	CPV33N	SVP32	BFTX03508	2.0	TRX10
VP25					
VP32					

■ Holders

Above figures show right hand tools.

Cat. No.	Conventional Cat. No.	Stock		Dimensions (mm)								Applicable Inserts	
		R	L	h	b	L ₁	f	h ₁	L ₂	e	Cat. No.	Ref. Page	
SVPC R/L1010-H11	—	●	●	10	10	100	14.5	10	—	4.5	VC□□1103	From B119	
SVPC R/L1212-H11	—	●	●	12	12	100	16.5	12	—	4.5			
SVPC R/L1616-H11	—	●	●	16	16	100	20.5	16	—	4.5			
SVPC R/L2020K16	SVPC R/L2020-33	●	●	20	20	125	25	20	35	5.0	VC□□1604	From B120	
SVPC R/L2525M16	SVPC R/L2525-33	●	●	25	25	150	32	25	35	7.0			
SVPC R/L3225P16	SVPC R/L3225-33	●	●	32	25	170	32	32	35	7.0			

External Holders

Positive Inserts

C

D

R

S

T

V

W

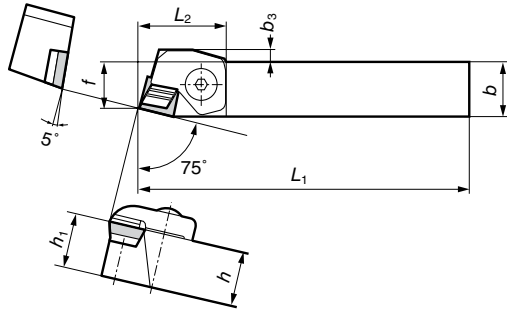
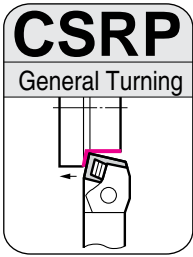
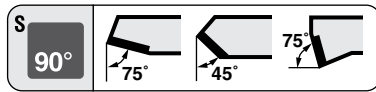

SEC- 40 Type Tool Holders

General Turning

Clamp-on

■ Holders

Above figures show right hand tools.

Cat. No.	Conventional Cat. No.	Stock		Dimensions (mm)							Applicable Inserts		Clamp	Chipbreaker	Bolt	Shim	Shim Pin	Spring	Spanner	
		R	L	h	b	L ₁	f	h ₁	L ₂	b ₃	Cat. No.	Ref. Page								
CSRP R/L1919-L12	FP11 R/L-33	●		19	19	140	15.5	19	34.5	5.0										
CSRP R/L2525-N12	FP11 R/L-44A	●		25	25	160	21.5	25	34.5	-	SP□□1203	B99	DCR/L1	CBD4R/L	BH0824R/L BH0830R/L	SSPD422			LH040	
CSRP R/L3225-N12	FP11 R/L-45A			32	25	160	21.5	32	34.5	-					BH0830R/L	SPP3	DSP5			
CSRP R/L2525-N15	FP11 R/L-44B	●		25	25	160	21.5	25	40.0	4.5	SP□□1504	B100	DCR/L3	CBD5R/L	BH1030R/L BH1036R/L	SSPD522		LH050		
CSRP R/L3232-N15	FP11 R/L-55			32	32	180	26.0	32	40.0	-										

■ Spare Parts

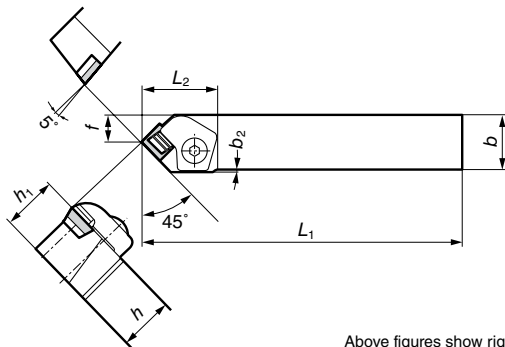
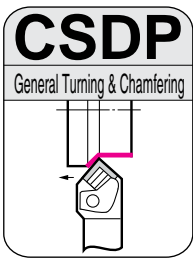
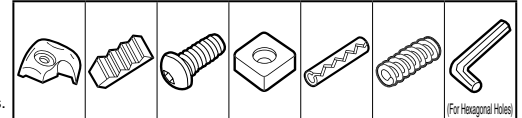

SEC- 40 Type Tool Holders

General Turning

Clamp-on

■ Holders

Above figures show right hand tools.

Cat. No.	Conventional Cat. No.	Stock		Dimensions (mm)							Applicable Inserts		Clamp	Chipbreaker	Bolt	Shim	Shim Pin	Spring	Spanner	
		R	L	h	b	L ₁	f	h ₁	L ₂	b ₂	Cat. No.	Ref. Page								
CSDP R/L1919-L12	FP14 R/L-33	●		19	19	140	10.5	19	35	6										
CSDP R/L2525-N12	FP14 R/L-44A	●		25	25	160	12.5	25	35	2	SP□□1203	B99	DCR/L1	CBD4R/L	BH0824R/L BH0830R/L	SSPD422	SPP3	DSP5	LH040	
CSDP R/L3225-N12	FP14 R/L-45A			32	25	160	12.5	32	35	2					BH0830R/L					

■ Spare Parts

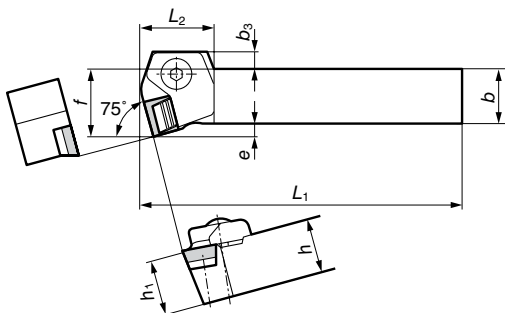
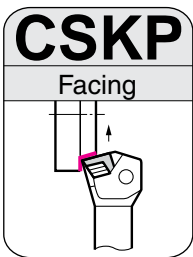
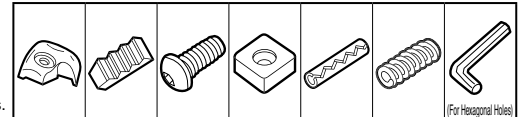

SEC- 40 Type Tool Holders

General Turning

Clamp-on

■ Holders

Above figures show right hand tools.

Cat. No.	Conventional Cat. No.	Stock		Dimensions (mm)							Applicable Inserts		Clamp	Chipbreaker	Bolt	Shim	Shim Pin	Spring	Spanner	
		R	L	h	b	L ₁	f	h ₁	L ₂	e	b ₃	Cat. No.								Ref. Page
CSKP R/L1919-L12	FP15 R/L-33			19	19	140	25	19	22	6	7									
CSKP R/L2525-N12	FP15 R/L-44A	●		25	25	160	32	25	22	7	-	SP□□1203	B99	DCL/R1	CBD4L/R	BH0830L/R BH0830L/R	SSPD422		LH040	
CSKP R/L3225-N12	FP15 R/L-45A			32	25	160	32	32	22	7	-						SPP3	DSP5		
CSKP R/L2525-N15	FP15 R/L-44B	●		25	25	160	31	25	28	6	7	SP□□1504	B100	DCL/R3	CBD5L/R	BH1030L/R BH1036L/R	SSPD522		LH050	
CSKP R/L3232-Q15	FP15 R/L-55			32	32	180	38	32	28	6	-									

■ Spare Parts

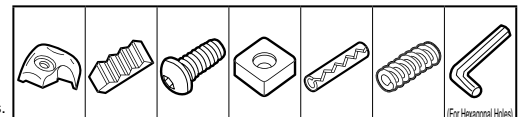

Note: When using right/left handed type inserts for facing, holder and insert are opposite handed.

C External Holders

Positive Inserts

C

D

R

S

T

V

W

CTGP / CTFP Type

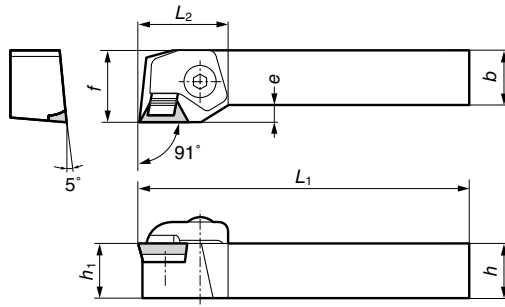
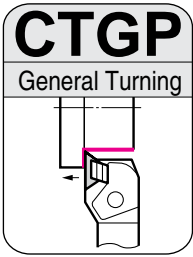
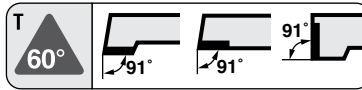

SEC- 40 Type Tool Holders

General Turning

Clamp-on

■ Spare Parts

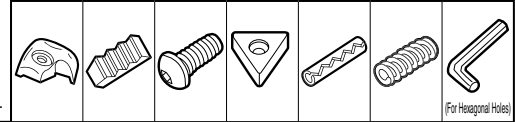

■ Holders

Above figures show right hand tools.

Cat. No.	Conventional Cat. No.	Stock		Dimensions (mm)							Applicable Inserts		Clamp	Chipbreaker	Bolt	Shim	Shim Pin	Spring	Spanner
		R	L	h	b	L ₁	f	h ₁	L ₂	e	Cat. No.	Ref. Page							
CTGP R/L2525-N16	FP21 R/L-44A	●		25	25	160	25	25	34.5	-	TP□□1603	B113	DCR/L2	CBD4R/L	BH0830R/L	STPD322			LH040
CTGP R/L3225-N16	FP21 R/L-45A			32	25	160	25	32	34.5	-			DCR/L2	CBD4R/L	BH0830R/L	STPD322		LH040	
CTGP R/L3232-Q22	FP21 R/L-55			32	32	180	32	32	41.0	-	TP□□2204	B114	DCR/L3	CBD5R/L	BH1036R/L	STPD422	SPP3	DSP5	LH050
CTGP R/L1919-L16	FP22 R/L-33	●		19	19	140	25	19	34.5	6	TP□□1603	B113	DCR/L2	CBD4R/L	BH0824R/L	STPD322		LH040	
CTGP R/L2525-N22	FP22 R/L-44B	●		25	25	160	32	25	41.0	7	TP□□2204	B114	DCR/L3	CBD5R/L	BH1030R/L	STPD422		LH050	

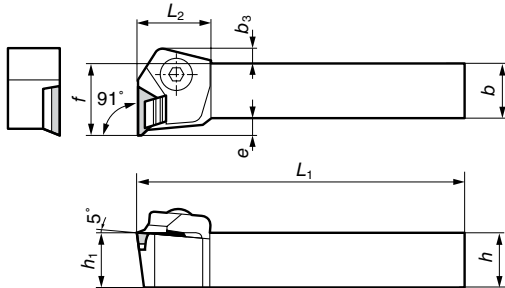
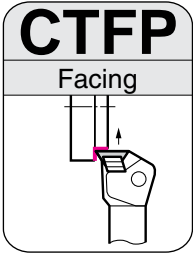

SEC- 40 Type Tool Holders

General Turning

Clamp-on

■ Spare Parts

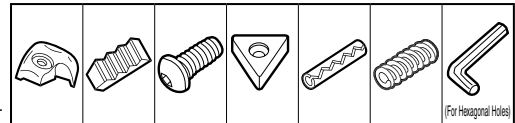

■ Holders

Above figures show right hand tools.

Cat. No.	Conventional Cat. No.	Stock		Dimensions (mm)								Applicable Inserts		Clamp	Chipbreaker	Bolt	Shim	Shim Pin	Spring	Spanner
		R	L	h	b	L ₁	f	h ₁	L ₂	e	b ₃	Cat. No.	Ref. Page							
CTFP R/L1919-L16	FP25 R/L-33	●		19	19	140	25	19	26	6	8			DCL/R2	CBD4L/R	BH0824L/R				
CTFP R/L2525-N16	FP25 R/L-44A	●		25	25	160	32	25	26	7	-	TP□□1603	B113	DCL/R2	CBD4L/R	BH0830L/R	STPD322		LH040	
CTFP R/L3225-N16	FP25 R/L-45A			32	25	160	32	32	26	7	-			DCL/R2	CBD4L/R	BH0830L/R		SPP3	DSP5	LH040
CTFP R/L2525-N22	FP25 R/L-44B	●		25	25	160	32	25	33	7	7	TP□□2204	B114	DCL/R3	CBD5L/R	BH1030L/R	STPD422		LH040	
CTFP R/L3232-Q22	FP25 R/L-55			32	32	180	39	32	33	7	-			DCL/R3	CBD5L/R	BH1036L/R			LH040	

Note: When using right/left handed type inserts for facing, holder and insert are opposite handed.

External Holders

Positive Inserts

C

D

R

S

T

V

W

MV / GD Type Copying Tool Holders

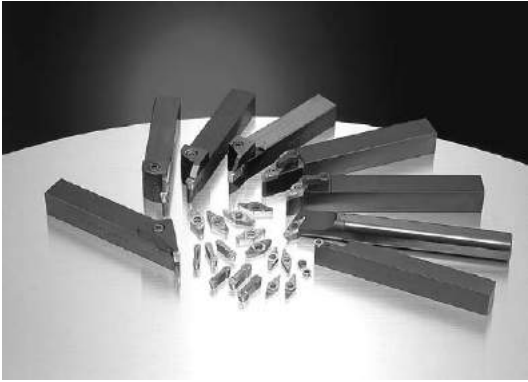

General Features

With a wide range of insert geometries (35° diamond shaped type, Dogbone type and Round type) available in both cemented carbide and diamond grades, we are able to provide superior performance for a vast variety of applications and cutting conditions.

Characteristics and Application

- 35° diamond shaped type chipbreakers for a wide range of applications from roughing to finishing process
AW type chipbreakers enable a stable roughing process with lower cutting force and a newly designed holder with high clamp rigidity.
- Wide variety of dogbone type chipbreakers
AW type chipbreakers feature a high rake design and newly designed special holders to support a variety of applications. Straight, 15° and 45° shapes are available.
- AW type chipbreakers for smooth chip control
- AG type chipbreakers for mirror finish and anti-adhesion

AW Type Chipbreaker

- 35° Diamond shaped Type
VCGT220520N-AW (H1)
- Dogbone Type
MDE4R-AW (H1)
MDE4R-AW (DA2200)

AG Type Chipbreaker

- 35° Diamond shaped Type
VCGT160408N-AG (H1)

Series

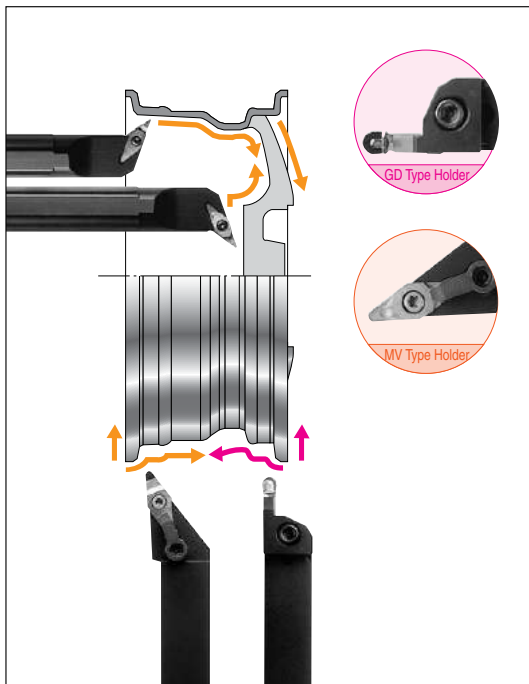

Description	Type	Page
SEC-GD Type	GDE R/L2525-600W/S	C35
	GDE R/L2525-800W/S	
	GDE R/L2525-615W/S	
	GDE R/L2525-815W/S	
	GDE R/L2525-645W/S	
	GDE R/L2525-845W/S	
SEC-SV Type	SVJC R/L2525M16	C29
	SVVC N2525M16	C30
	SVPC R/L2525M16	
SEC-MV Type	MVXC R/L2525-22-20	C34
	MVXC R/L2525-22-30	
	MVPC R/L2525-22-20	
	MVPC R/L2525-22-30	
SEC-D Type	DVJN R/L2525 M16	C26
	DVVN N2525 M16	
	DVQN R/L2525 M16	
SEC-Boring Bar	S25R-SVQC R/L1604-35	E56
	S32S-SVQC R/L1604-40	E57
	S40T-SVQC R/L1604-50	
	S25R-SVUC R/L1604-35	
	S32S-SVUC R/L1604-40	E58
S40T-SVUC R/L1604-50		

Application Examples

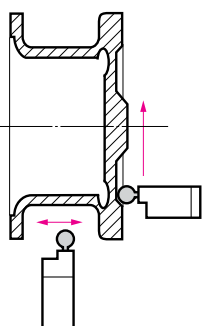

● **Cutting Conditions**
 Cat. No. : GDER2525-800W
 Cutter Insert : MDE4R-AW
 Grades : H1
 $n=2,000\text{min}^{-1}$
 $f=0.4 \text{ to } 0.6\text{mm/rev}$
 $a_p=2.0\text{mm Wet}$

● **Results**
 Excellent chip control of AW type chipbreaker guarantees an increase in productivity.

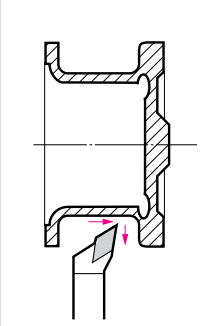

● **Cutting Conditions**
 Cat. No. : SVJCR2525-33
 Cutter Insert : VCMT160412
 Grades : DA1000
 $v_c=2,500\text{m/min}$
 $f=0.35\text{mm/rev}$
 $a_p=0.2\text{mm Wet}$

● **Results**
 DA1000 has excellent toughness, and provides over 17 times tool life when compared to competitor's PCD.

DA1000 3,500pcs
 Comp.PCD 200pcs

Tool Life

C

External Holders

Positive Inserts

C

D

R

S

T

V

W

Special

SEC- MV Type MINI Tool Holders

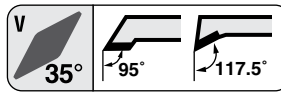

35° Diamond Type

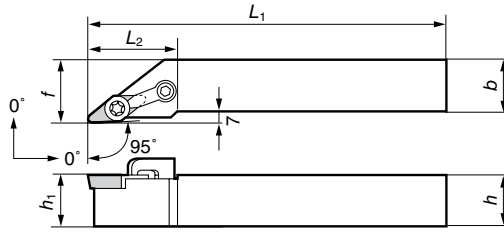
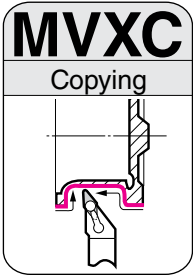

Spare Parts

CCM8-LONG	WB8-24	BFTX0515N	TRX20	LH040

Holders

Above figures show right hand tools.

Cat. No.	Conventional Cat. No.	Stock		Dimensions (mm)						Clamp	Double Screw	Screw	Spanner	Spanner for Clamp Screws
		R	L	h	b	L ₁	f	h ₁	L ₂					
★ MVXC R/L2525-22-20	MVXC R/L2525-2220	●	●	25	25	180	32	25	45	CCM8-LONG	WB8-24	BFTX0515N	TRX20	LH040
☆ MVXC R/L2525-22-30	MVXC R/L2525-2230	●	●	25	25	180	32	25	45					

★ : For nose radius 2.0mm insert. ☆ : For nose radius 3.0mm insert.

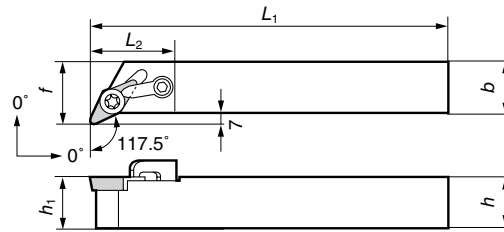
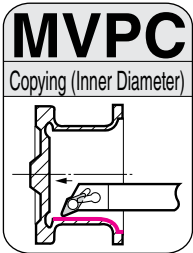

Spare Parts

CCM8-LONG	WB8-24	BFTX0515N	TRX20	LH040

Holders

Above figures show right hand tools.

Cat. No.	Conventional Cat. No.	Stock		Dimensions (mm)						Clamp	Double Screw	Screw	Spanner	Spanner for Clamp Screws
		R	L	h	b	L ₁	f	h ₁	L ₂					
★ MVPC R/L2525-22-20	MVPC R/L2525-2220	●	●	25	25	180	32	25	41	CCM8-LONG	WB8-24	BFTX0515N	TRX20	LH040
☆ MVPC R/L2525-22-30	MVPC R/L2525-2230	●	●	25	25	180	32	25	41					

★ : For nose radius 2.0mm insert. ☆ : For nose radius 3.0mm insert.

Inserts (Coated Carbide/ Carbide/ SUMIDIA)

● 35° Diamond Type

Shape	Cat. No.	Stock					Dimensions (mm)			Applicable Holder
		EH10Z	G10E	H1	DA1000	DA2200	Inscribed Circle	Thickness	Nose Radius	
	VCGT220520N-AW	-	-	●	-	-	12.70	5.56	2.0	MVXC Type MVPC Type
	VCGT220530N-AW	-	-	●	-	-	12.70	5.56	3.0	
	VCGT220530N-AG	-	-	●	-	-	12.70	5.56	3.0	MVXC Type MVPC Type
	VCGT220530N-AG	-	-	●	-	-	12.70	5.56	3.0	
	VCMT220520	-	-	-	●	▲	12.70	5.56	2.0	SVJC Type (→ C29) SVVC Type (→ C30) SVPC Type (→ C30)
	VCMT220530	-	-	-	●	▲	12.70	5.56	3.0	
	VCGT160408N-AW	-	-	●	-	-	9.525	4.76	0.8	DVVN Type (→ C26) DVJN Type (→ C26) DVQN Type (→ C26)
	VCGT160412N-AW	-	-	●	-	-	9.525	4.76	1.2	
	VCGT160408N-AG	-	-	●	-	-	9.525	4.76	0.8	DVVN Type (→ C26) DVJN Type (→ C26) DVQN Type (→ C26)
	VCGT160412N-AG	-	-	●	-	-	9.525	4.76	1.2	
	NF-VCMT160404	-	-	-	●	▲	9.525	4.76	0.4	DVVN Type (→ C26) DVJN Type (→ C26) DVQN Type (→ C26)
	NF-VCMT160408	-	-	-	●	▲	9.525	4.76	0.8	
	NF-VCMT160412	-	-	-	●	▲	9.525	4.76	1.2	DVVN Type (→ C26) DVJN Type (→ C26) DVQN Type (→ C26)
	VCMT160408	-	-	-	●	▲	9.525	4.76	0.8	
	VCMT160412	-	-	-	●	▲	9.525	4.76	1.2	DVVN Type (→ C26) DVJN Type (→ C26) DVQN Type (→ C26)
	VCMT160412	-	-	-	●	▲	9.525	4.76	1.2	
	VCMT160412-WF	-	-	-	●	▲	9.525	4.76	1.2	DVVN Type (→ C26) DVJN Type (→ C26) DVQN Type (→ C26)
	VCMT160412-WF	-	-	-	●	▲	9.525	4.76	1.2	
	VNMG160404N-UP	-	●	-	-	-	9.525	4.76	0.4	DVVN Type (→ C26) DVJN Type (→ C26) DVQN Type (→ C26)
	VNMG160408N-UP	-	●	-	-	-	9.525	4.76	0.8	
	NF-VNMX160404	-	-	-	●	▲	9.525	4.76	0.4	DVVN Type (→ C26) DVJN Type (→ C26) DVQN Type (→ C26)
	NF-VNMX160408	-	-	-	●	▲	9.525	4.76	0.8	
	NF-VNMX160412	-	-	-	●	▲	9.525	4.76	1.2	DVVN Type (→ C26) DVJN Type (→ C26) DVQN Type (→ C26)
	NF-VNMX160412	-	-	-	●	▲	9.525	4.76	1.2	
	VNMX160404	-	-	-	●	▲	9.525	4.76	0.4	DVVN Type (→ C26) DVJN Type (→ C26) DVQN Type (→ C26)
	VNMX160408	-	-	-	●	▲	9.525	4.76	0.8	
	VNMX160412	-	-	-	●	▲	9.525	4.76	1.2	DVVN Type (→ C26) DVJN Type (→ C26) DVQN Type (→ C26)
	VNMX160412	-	-	-	●	▲	9.525	4.76	1.2	

VNMG160404N-UP (UP Type Chipbreaker) is available in AC820P and AC830P grades.

External Holders

Positive Inserts

C

D

R

S

T

V

W

Dogbone Insert

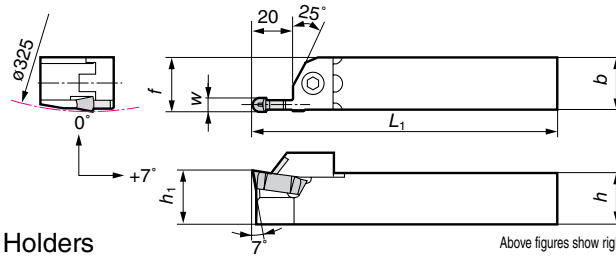
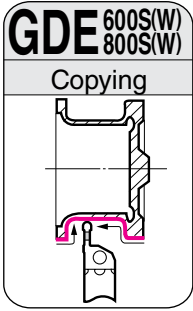

■ Holders

Cat. No.	Stock		Dimensions (mm)						Carbide Piece Clamp	Special Steel Clamp	Cap Screw	Spanner
	R	L	h	b	L ₁	f	h ₁	w				
◆ GDE R/L2525-600S	●	●	25	25	150	26	25	6	—	GDS600R/L	BX0625	LH050
◇ GDE R/L2525-800S	●	●	25	25	150	26	25	8	—	GDS800R/L		
◆ GDE R/L2525-600W	●	●	25	25	150	26	25	6	GDW600R/L	—		
◇ GDE R/L2525-800W	●	●	25	25	150	26	25	8	GDW800R/L	—		

■ Spare Parts

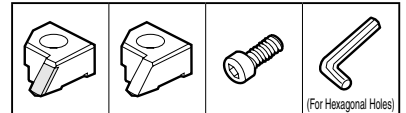

◆ : For nose radius 3.0mm insert. ◇ : For nose radius 4.0mm insert.

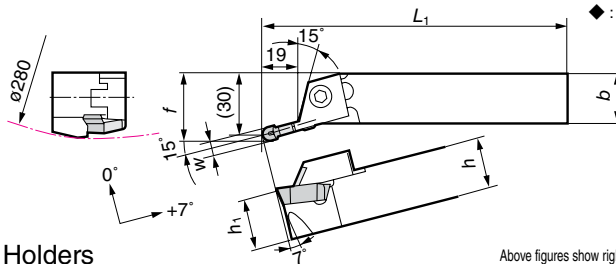
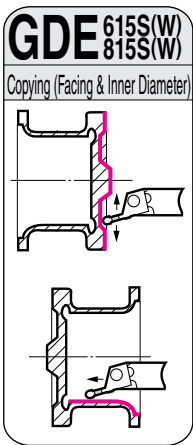

■ Holders

Cat. No.	Stock		Dimensions (mm)						Carbide Piece Clamp	Special Steel Clamp	Cap Screw	Spanner
	R	L	h	b	L ₁	f	h ₁	w				
◆ GDE R/L2525-615S	●	●	25	25	150	32.2	25	6	—	GDS615R/L	BX0625	LH050
◇ GDE R/L2525-815S	●	●	25	25	150	33.2	25	8	—	GDS815R/L		
◆ GDE R/L2525-615W	●	●	25	25	150	32.2	25	6	GDW615R/L	—		
◇ GDE R/L2525-815W	●	●	25	25	150	33.2	25	8	GDW815R/L	—		

■ Spare Parts

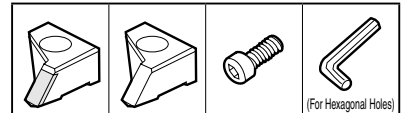

◆ : For nose radius 3.0mm insert. ◇ : For nose radius 4.0mm insert.

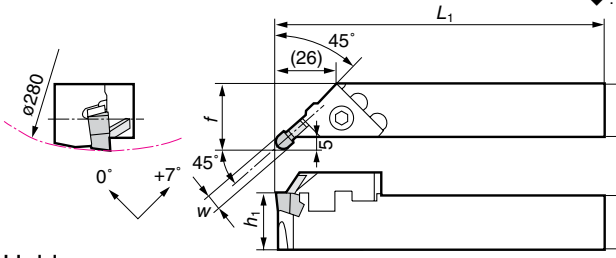
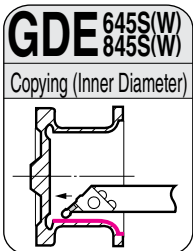

■ Holders

Cat. No.	Stock		Dimensions (mm)						Carbide Piece Clamp	Special Steel Clamp	Cap Screw	Spanner
	R	L	h	b	L ₁	f	h ₁	w				
◆ GDE R/L2525-645S	●	●	25	25	150	30	25	6	—	GDS645R/L	BX0625	LH050
◇ GDE R/L2525-845S	●	●	25	25	150	30	25	8	—	GDS845R/L		
◆ GDE R/L2525-645W	●	●	25	25	150	30	25	6	GDW645R/L	—		
◇ GDE R/L2525-845W	▲	▲	25	25	150	30	25	8	GDW845R/L	—		

■ Spare Parts

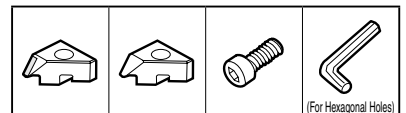

◆ : For nose radius 3.0mm insert. ◇ : For nose radius 4.0mm insert.

■ Inserts (Coated Carbide / Carbide / SUMIDIA)

● Dogbone Type

Shape	Cat. No.	Stock				Dimension (mm)			Applicable Holder	Fig	Fig
		EH10Z	G10E	H1	DA2200	Total Length (ℓ)	Thickness (s)	Nose Radius (r _ε)			
	MDE3R-AW	—	—	—	●	26	8.5	3.0	6	◆	1
	MDE4R-AW	—	—	—	●	30	8.5	4.0	8	◇	
	MDE3R	—	—	—	●	26	8.5	3.0	6	◆	2
	MDE4R	—	—	—	●	30	8.5	4.0	8	◇	
	MDE3R-AW	—	—	—	●	26	8.5	3.0	6	◆	3
	MDE4R-AW	—	—	—	●	30	8.5	4.0	8	◇	

▲ mark : To be replaced by new item (Please confirm stock availability)

C External Holders

Positive Inserts

C

D

R

S

T

V



W

Special

Double Clamp Tool Holders

Clamp Set Parts

■ Spare Parts

Applicable Clamp Sets Cat. No.	Clamp		Spring		Cap Screw		Recommended Tightening Torque(N.m)
					 (Screw can be turned from both ends.)		
	Cat. No.	Stock	Cat. No.	Stock	Cat. No.	Stock	
SCP-1	CP1	●	CSP08	●	CP-M5-20-1	●	5.0
SCP-2	CP2	●	CSP08	●	CP-M5-20-1	●	
SCP-3	CP3	●	CSP08	●	CP-M5-20-1	●	
SCP-4	CP4	●	CSP08	●	CP-M5-20-1	●	
SCP-5	CP5	●	CSP08	●	CP-M5-20-1	●	
SCP-6	CP6	●	CSP12	●	CP-M8-30-1	●	6.0

External Holders

C

D

R

S

T

V

W