

Milling Cutters (Special Purpose)

H133 to H147

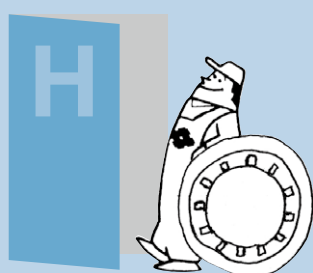
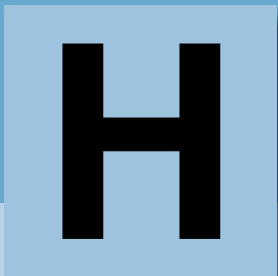

H

Milling Cutters
(Special Purpose)

GOAL
MILL

HIGH
FEED

Quick
Change

High Feed Finishing of Cast Iron	SEC-GOALMILL Series.....	H134
	GFX13000 Type/16000 Type	H138
	GFS13000 Type	H139
	GSV16000 Type	H140
	GRV16000 Type	H141
High Feed Finishing of Cast Iron	SEC-High-Feed Facemills	H142
	Cutting Edge Reference System	H143
	NRV4000 Type/5000 Type, DPV4000 Type/5000 Type	H144
	NFV4000 Type/5000 Type	H145
High Feed Finishing of Non-Ferrous Alloy/Thin Work Pieces	APV5000 Type	H145
QC System	Quick Change System	H146
	Applicable Cutter for QC-system	H147

Stock Indications and Symbols

- mark: Standard stocked item
- mark: To be replaced by a new item featured on the same page
- ▲ mark: To be replaced by new item
(Please confirm stock availability)

- * mark: Semi-standard stock (Please confirm stock availability)
- mark: Stock or planned stock (Please confirm stock availability)
- No mark: Made-to-order item
- mark: We cannot produce

H133

GFX/GFS/GSV/GRV Type



General Features

SEC-Goal Mill cutters use tangentially-mounted screw-locking inserts developed for high efficiency machining and finishing of cast iron parts such as engine cylinder blocks, transmission cases, etc.

Characteristics

- Special cutters for high feed machining of cast iron
- Highly reliable shoulder milling cutter with tangential inserts
- Multi-edged design (approx. 3 edges per inch)
- Finishing models feature an easy-to-use edge runout fine adjustment
- Chipbreaker type inserts for low cutting force

Series

Series Code	GFX Type	GFS Type	GSV Type	GRV Type
Application	Finishing	Finishing/Shoulder Milling	Medium Finishing	Roughing
Surface Roughness	< Ra3.2	< Ra3.2	< Ra6.3	< Ra 12.5
Appearance				

Refer to pages H146 and H147 for details and specifications on the two piece mounting system and adapter.

H
 Milling Cutters
 (Special Purpose)
 GOAL MILL
 HIGH FEED
 Quick Change

	Finishing to General Machining	Heavy Interrupted Machining
	ACK260	ACK280

Characteristic Values of Grades

Classification	Grade	Hardness(HRA)	Toughness(GPa)	Main Coating Components	Coating Thickness(μm)	Characteristics
	ACK260	92.6	2.6	Super ZX Coat	3	<ul style="list-style-type: none"> • For finishing to general machining of cast iron and ductile cast iron. • Employs new PVD coating consisting of multiple nanometre-thin layers of TiAlN and AlCrN, coupled with a tough, heat-resistant substrate for long and stable tool life.
	ACK280	91.7	3.0	Super ZX Coat	3	<ul style="list-style-type: none"> • For heavy interrupted cutting and wet cutting of cast iron and ductile cast iron. • Employs new PVD coating consisting of multiple nanometre-thin layers of TiAlN and AlCrN, coupled with an ultra-tough substrate for superior fracture resistance, and thermal crack resistance during wet cutting.

SEC-Goal Mill GFX/GFS/GSV/GRV Type

Application Examples

Application : Rough Cutting

● Work : Top Face Of Cylinder Block		SEC-Goal Mill	Current Tool					
Work Material : FC250 Roughness Standard : Ra 6.3 μm Equipment : Special Machine 	Tool	GRV16250R	ø250 (Special)					
	Grade	ACK100	PVD					
	Tool Shape	Tangential Screw Locked	Wedge Type					
	No. of Teeth	30	30					
	V_c (m/min)	80	80					
	V_f (mm/min)	611	611					
	f_z (mm/t)	0.20	0.20					
	a_p (mm)	3.0 (Some Areas 6.0)	3.0 (Some Areas 6.0)					
	Coolant	Remainder Wet	Remainder Wet					
	Results	<table border="1"> <tr> <th>Tool</th> <th>Workpieces/Corner</th> </tr> <tr> <td>GRV</td> <td>300 Units</td> </tr> <tr> <td>Current Tool</td> <td>100 Units</td> </tr> </table>	Tool	Workpieces/Corner	GRV	300 Units	Current Tool	100 Units
Tool	Workpieces/Corner							
GRV	300 Units							
Current Tool	100 Units							
Evaluation	Eliminates breakage for extended tool life.							

Application : Finishing to Rough Cutting

● Work : Top Face Of Cylinder Block		SEC-Goal Mill	Competitor's Product
Work Material : FC250 Roughness Standard : Ra 3.2 μm Equipment : Special Machine 	Tool	GSV ø265	ø250
	Grade	ACK260 / ACK200 (Finishing / Roughing)	PVD
	Tool Shape	Tangential Screw Locked	Tangential Screw Locked
	No. of Teeth	24	24
	V_c (m/min)	265	250
	V_f (mm/min)	763	509
	f_z (mm/t)	0.10/0.60	0.10
	a_p (mm)	3.0	3.0
	Coolant	Wet	Wet
	Results	Initial Roughness Ra: 0.3 μm Finished surface equivalent to CBN.	

Application : One-Pass Finishing

● Work : Front Face Of Cylinder Block		SEC-Goal Mill
Work Material : FC250 Roughness Standard : Ra 6.3 μm Equipment : Special Machine 	Tool	GSV16315R
	Grade	ACK260
	Tool Shape	Tangential Screw Locked
	No. of Teeth	36
	V_c (m/min)	136
	V_f (mm/min)	693
	f_z (mm/t)	0.14
	a_p (mm)	Max. 6.0
	Coolant	Dry
	Results	What would normally require two processes (roughing and finishing) was finished in a single process, reducing process time.

Application : Finishing

● Work : Side Face Of Cylinder Block		SEC-Goal Mill	Competitor's Product
Work Material : FC250 Roughness Standard : Rz 12.5 μm Equipment : Horizontal Machining Centre 	Tool	GFXC13100R	ø100
	Grade	BN7000	CVD
	Tool Shape	Tangential Screw Locked	Wedge Type
	No. of Teeth	4	10
	V_c (m/min)	1,200	251
	V_f (mm/min)	10,000	500
	f_z (mm/t)	0.65	0.063
	a_p (mm)	0.5	0.5
	Coolant	Dry	Dry
	Results	<ul style="list-style-type: none"> $V_f = 10,000$ mm/min Achieves a V_f value that is 20 times larger than our competitors' products. 	

Application : Finishing

● Work : Side Face Of Cylinder Block		SEC-Goal Mill	Competitor's Product
Work Material : FC250 Roughness Standard : Rz 12.5 μm Equipment : Horizontal Screw Locked 	Tool	GFXC13125R	ø125
	Grade	BN7000	PVD
	Tool Shape	Tangential Screw Locked	Horizontal Screw Locked
	No. of Teeth	4	12
	V_c (m/min)	1,000	216
	V_f (mm/min)	6,000	376
	f_z (mm/t)	0.59	0.057
	a_p (mm)	0.5	1.0
	Coolant	Dry	Dry
	Results	<ul style="list-style-type: none"> $V_f = 6,000$ mm/min Improves efficiency by 16 times and provides better surface roughness than our competitors' products. 	

Application : Finishing

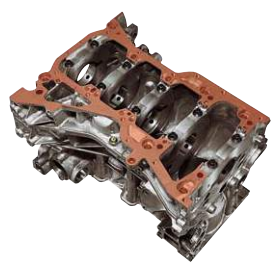
● Work : Bottom Face Of Cylinder Block		SEC-Goal Mill	Conventional Grade
Work Material : FC250 Roughness Standard : Ra 6.3 μm Equipment : Horizontal Machining Centre 	Tool	GFXC13125R	ø125
	Grade	ACK260	CBN
	Tool Shape	Tangential Screw Locked	Wedge Type
	No. of Teeth	10	4
	V_c (m/min)	250	510
	V_f (mm/min)	1,020	1,020
	f_z (mm/t)	0.16	0.20
	a_p (mm)	0.5	0.5
	Coolant	Remainder Wet	Remainder Wet
	Results	<ul style="list-style-type: none"> Carbide tools providing a tool life as long as CBN cutters. Reduces costs. 	

Application : Finishing

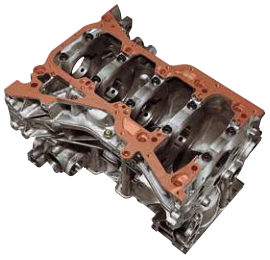
● Work : Bottom Face Of Cylinder Block		SEC-Goal Mill	Competitor's Product					
Work Material : FC250 Roughness Standard : Ra 3.2 μm Equipment : Special Machine 	Tool	GFX16315R (Special)	ø315					
	Grade	ACK260	PVD					
	Tool Shape	Tangential Screw Locked	Wedge Type					
	No. of Teeth	44 (effective)	40					
	V_c (m/min)	148	148					
	V_f (mm/min)	720	720					
	f_z (mm/t)	0.11	0.12					
	a_p (mm)	0.5	0.5					
	Coolant	Dry	Dry					
	Results	<table border="1"> <tr> <th>Tool</th> <th>Workpieces/Corner</th> </tr> <tr> <td>GSV</td> <td>3,500 Units</td> </tr> <tr> <td>Competitor's Product</td> <td>2,300 Units</td> </tr> </table>	Tool	Workpieces/Corner	GSV	3,500 Units	Competitor's Product	2,300 Units
Tool	Workpieces/Corner							
GSV	3,500 Units							
Competitor's Product	2,300 Units							
Evaluation	Provides a tool life that is approximately 1.5 times longer than our competitors' products.							

Application : Finishing

● Work : Lathe Bed		SEC-Goal Mill	Competitor's Product
Work Material : FC250 Roughness Standard : Ra 6.3 μm Equipment : Double Column Machining Centre 	Tool	GFX16125R	ø125
	Grade	ACK260	Ceramics
	Tool Shape	Tangential Screw Locked	—
	No. of Teeth	16	10
	V_c (m/min)	300	785
	V_f (mm/min)	3,057	3,000
	f_z (mm/t)	0.25	0.15
	a_p (mm)	0.3	0.3
	Coolant	Dry	Dry
	Results	Equivalent v_f value to ceramics achieved with carbide	
Evaluation	Reduced running costs		

Milling Cutters
(Special Purpose)

GOAL MILL
HIGH FEED
Quick Change

GFX/GFS/GSV/GRV Type

Application Examples

Application : Finishing

● Work : Housing		SEC-Goal Mill	Competitor's Product
Work Material : FC250 Roughness Standard : Ra 1.6μm Equipment : Horizontal Machining Centre	Tool	GFX13100R	ø100
	Grade	ACK260	CVD
	Tool Shape	Tangential Screw Locked	Horizontal Screw Locked
	No. of Teeth	8	10
	V _c (m/min)	250	250
	V _f (mm/min)	960	530
	f _z (mm/t)	0.15	0.066
	a _p (mm)	0.1	0.1
	Coolant	Dry	Dry
	Results	· Provides higher efficiency, accuracy, and visibility compared to our competitors' products. · Achieves a tool life that is over 2.5 times longer than our competitors' products.	



Application : Finishing

● Work : Large Diesel Engine (Base Plate)		SEC-Goal Mill	Current Tool
Work Material : FC250-FC300 Roughness Standard : Ra 3.2μm Size : 1,600mm×1,800mm Equipment : Horizontal Machining Centre	Tool	GFX16160R	ø160
	Grade	ACK260	CBN
	Tool Shape	Tangential Screw Locked	Blade Type
	No. of Teeth	20	10
	V _c (m/min)	300	980
	V _f (mm/min)	2,980	1,950
	f _z (mm/t)	0.25	0.10
	a _p (mm)	0.3	0.3
	Coolant	Dry	Dry
	Results	Carbide tools achieve 1.5 times the efficiency of CBN and provides machined surfaces equivalent to those machined with CBN on visual inspection.	



Application : Finishing

● Work : Side of Lathe Bed (11m Long)		SEC-Goal Mill	Competitor's Product					
Work Material : FC300 Roughness Standard : Ra 3.2μm Equipment : Horizontal Machining Centre	Tool	GFX16160R	ø160					
	Grade	ACK260	CVD					
	Tool Shape	Tangential Screw Locked	Horizontal Screw Locked					
	No. of Teeth	20	8					
	V _c (m/min)	120	125					
	V _f (mm/min)	477	400					
	f _z (mm/t)	0.10	0.20					
	a _p (mm)	0.3	0.3					
	Coolant	Dry	Dry					
	Results	<table border="1"> <tr> <td>Tool</td> <td>Cutting Length/Corner</td> </tr> <tr> <td>GFX</td> <td>40m</td> </tr> <tr> <td>Competitor's Product</td> <td>10m</td> </tr> </table> Provides a cutting length that is 4 times longer than our competitors' products.		Tool	Cutting Length/Corner	GFX	40m	Competitor's Product
Tool	Cutting Length/Corner							
GFX	40m							
Competitor's Product	10m							
Evaluation	<table border="1"> <tr> <td>Tool</td> <td>Workpieces/Corner</td> </tr> <tr> <td>GFX</td> <td>148 Units</td> </tr> <tr> <td>Competitor's Product</td> <td>100 Units</td> </tr> </table> Provides higher efficiency, accuracy, and visibility compared to our competitors' products.		Tool	Workpieces/Corner	GFX	148 Units	Competitor's Product	100 Units
Tool	Workpieces/Corner							
GFX	148 Units							
Competitor's Product	100 Units							



Application : Finishing

● Work : Angle Plate		SEC-Goal Mill
Work Material : FC300 Roughness Standard : Ra 3.2μm Equipment : Horizontal Machining Centre	Tool	GFS13125R
	Grade	ACK260
	Tool Shape	Tangential Screw Locked
	No. of Teeth	6
	V _c (m/min)	137
	V _f (mm/min)	1,000
	f _z (mm/t)	0.47
	a _p (mm)	0.015
	Coolant	Dry
	Results	Surface roughness: Ra 1.0μm No level differences. Final grinding process eliminated.

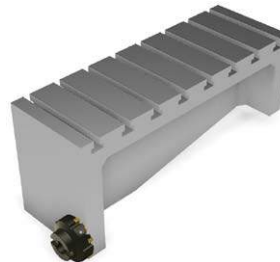

Application : Finishing

● Work : Hydraulic Component		SEC-Goal Mill	Competitor's Product					
Work Material : FCD450 Roughness Standard : Ra 3.2μm Equipment : Double Column Machining Centre	Tool	GFX13080R	ø80					
	Grade	ACK260	PVD					
	Tool Shape	Tangential Screw Locked	Horizontal Screw Locked					
	No. of Teeth	8	6					
	V _c (m/min)	218	180					
	V _f (mm/min)	1,600	650					
	f _z (mm/t)	0.23	0.15					
	a _p (mm)	0.1	0.1					
	Coolant	Wet	Wet					
	Results	<table border="1"> <tr> <td>Tool</td> <td>Workpieces/Corner</td> </tr> <tr> <td>GFX</td> <td>148 Units</td> </tr> <tr> <td>Competitor's Product</td> <td>100 Units</td> </tr> </table> Provides higher efficiency, accuracy, and visibility compared to our competitors' products.		Tool	Workpieces/Corner	GFX	148 Units	Competitor's Product
Tool	Workpieces/Corner							
GFX	148 Units							
Competitor's Product	100 Units							
Evaluation	Provides higher efficiency, accuracy, and visibility compared to our competitors' products.							



Application : Finishing

● Work : Rear Hub Carrier		SEC-Goal Mill	Current Tool
Work Material : FCD450 Roughness Standard : Rz 25μm Equipment : Horizontal Machining Centre	Tool	GFX16100R	ø100
	Grade	ACK260	CVD
	Tool Shape	Tangential Screw Locked	Wedge Type
	No. of Teeth	12	14
	V _c (m/min)	250	150
	V _f (mm/min)	3,150	800
	f _z (mm/t)	0.33	0.12
	a _p (mm)	0.5-1.0	0.5-1.0
	Coolant	Wet	Wet
	Results	· Current tools make level differences in machined surfaces. · Efficiency improved.	



Application : Finishing

● Work : Hydraulic Component		SEC-Goal Mill	Conventional					
Work Material : FCD600 Roughness Standard : Ra 1.6μm Equipment : Horizontal Machining Centre	Tool	GFX16125R (Special)	ø125					
	Grade	ACK260	PVD					
	Tool Shape	Tangential Screw Locked	Wedge Type					
	No. of Teeth	6	6					
	V _c (m/min)	160	150					
	V _f (mm/min)	733	110					
	f _z (mm/t)	0.30/1.20	0.05					
	a _p (mm)	0.25	0.25					
	Coolant	Wet	Wet					
	Results	<table border="1"> <tr> <td>Tool</td> <td>Life Time/Corner</td> </tr> <tr> <td>GFX</td> <td>350 min</td> </tr> <tr> <td>Competitor's Product</td> <td>150 min</td> </tr> </table> Provides a tool life that is approximately 2.3 times longer than our Conventional		Tool	Life Time/Corner	GFX	350 min	Competitor's Product
Tool	Life Time/Corner							
GFX	350 min							
Competitor's Product	150 min							
Evaluation	Provides a tool life that is approximately 2.3 times longer than our Conventional							

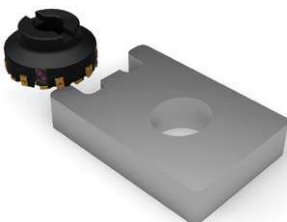

Application : Simultaneous Finishing

● Work : Crankcase		SEC-Goal Mill	Competitor's Product					
Work Material : AI + FC250 Roughness Standard : Ra 3.2μm Equipment : Vertical Machining Centre	Tool	GFX13100R	ø100					
	Grade	ACK260	PVD					
	Tool Shape	Tangential Screw Locked	Vertical Drawing Pins					
	No. of Teeth	12	12					
	V _c (m/min)	400	314					
	V _f (mm/min)	1,529	1,440					
	f _z (mm/t)	0.10	0.12					
	a _p (mm)	0.3	0.3					
	Coolant	Wet	Wet					
	Results	<table border="1"> <tr> <td>Tool</td> <td>Workpieces/Corner</td> </tr> <tr> <td>GFX</td> <td>250 Units</td> </tr> <tr> <td>Competitor's Product</td> <td>100 Units</td> </tr> </table> Provides a tool life that is approximately 2.5 times longer than our competitors' products.		Tool	Workpieces/Corner	GFX	250 Units	Competitor's Product
Tool	Workpieces/Corner							
GFX	250 Units							
Competitor's Product	100 Units							
Evaluation	Provides a tool life that is approximately 2.5 times longer than our competitors' products.							



■ GFX Type Features

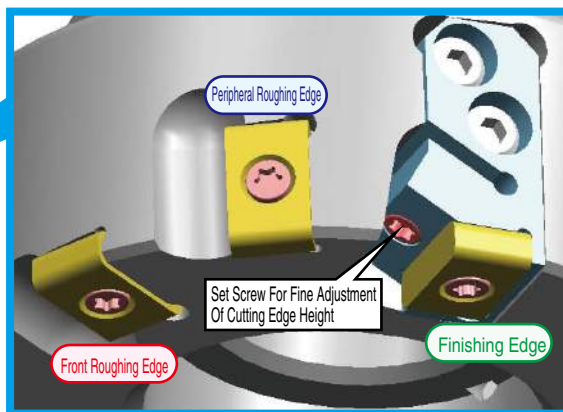
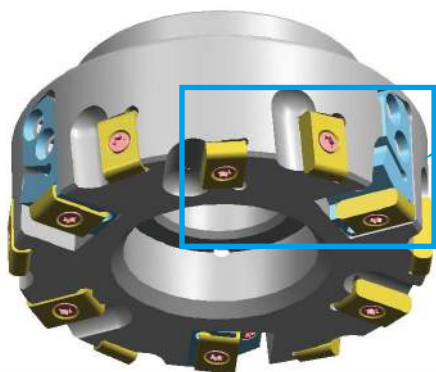

Finishing edge run-out can be adjusted by $5\mu\text{m}$ or less simply by turning set screw.

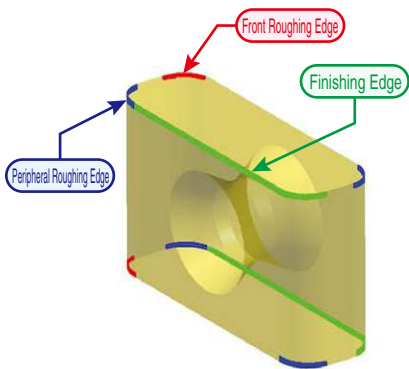

Arranging the same number of vertical and horizontal inserts allows 8-corner configuration.

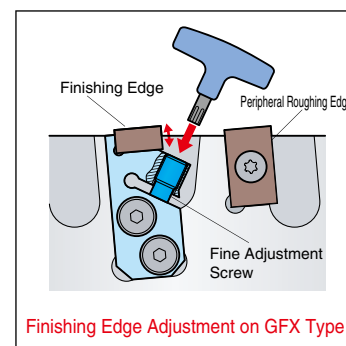
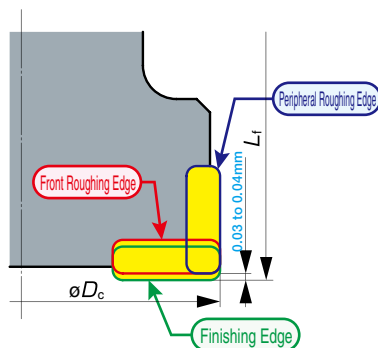

■ GFX Type Finishing Edge Run-Out Adjustment Procedure

<p>(1) Attach Insert</p> <p>Attach insert to cutter body. When doing so, check that the cartridge adjustment set screw is completely loose.</p>	<p>Adjustment Set Screw</p> <p>Peripheral Roughing Edge (Direct-Mounted)</p> <p>Front Roughing Edge (Direct-Mounted)</p> <p>Finishing Edge (Cartridges)</p>	<p>(4) Adjust Finishing Edge Height</p> <p>Select a finishing edge and adjust the set screw so that the edge sticks up around 0.03 to 0.04mm compared to (3).</p>	<p>$+0.03 \text{ to } 0.04\text{mm}$</p>
<p>(2) Check Roughing Edge Run-Out</p> <p>Measure face run-out of roughing edge and check the cutting edge that sticks up the most.</p>		<p>(5) Adjust Run-Out</p> <p>With the finishing edge from (4) as a reference, adjust the position of the other finishing edges so that run-out is equal to or less than $5\mu\text{m}$.</p>	<p>Run-Out: $5\mu\text{m}$ or less*</p>
<p>(3) Set Reference Roughing Edge</p> <p>Set the cutting edge height checked in (2) as "0".</p>	<p>Highest Roughing Edge</p> <p>0</p>	<p>!</p> <ul style="list-style-type: none"> Always adjust finishing edge height before use. Using the tool with the set screw loosened may result in tool breakage. <p>*Adjusting finishing edge run-out to $2\mu\text{m}$ or less will result in a better machined surface.</p>	

Rake Angle	Radial	-8°
	Axial	-5°

1mm 89° to 89.30°

P	M	K	N	S	H
Steel	Stainless Steel	Cast Iron	Non-Ferrous Metal	Exotic Alloy	Hardened Steel

High Feed Finishing Of Cast Iron

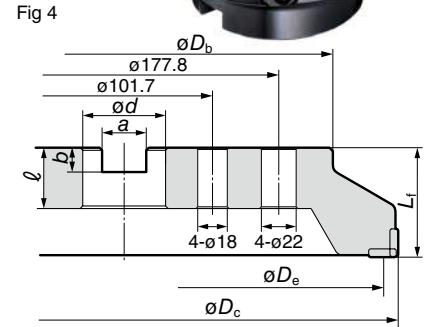
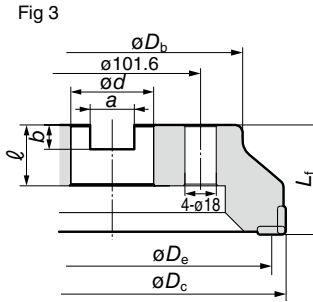
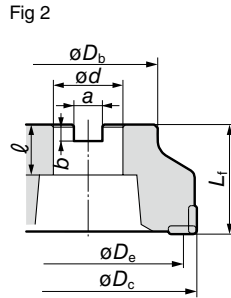
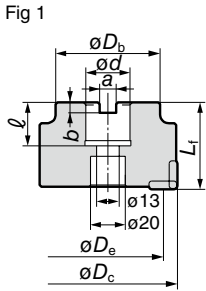

Body (GFX 16000)

Imperial

Cat. No. (R)	Stock	Cat. No. (L)	Stock	Dimensions (mm)								Total Teeth	No. of Finishing Edges	Effective Teeth	Weight (kg)	Fig
				ϕD_c	ϕD_e	ϕD_b	L_f	ϕd	a	b	ℓ					
GFX 13080R	●	GFX 13080L		*80	67.3	60	50	25.4	9.5	6	25	8	2	8	1.4	1
13100R	●	13100L		100	87.3	70	50	31.75	12.7	8	32	12	3	12	1.9	2
13125R	●	13125L		125	112.3	80	63	38.1	15.9	10	38	16	4	16	3.3	2
13160R	●	13160L		160	147.3	120	63	50.8	19.1	11	38	20	5	20	6.4	2
13200R		13200L		200	187.3	150	63	47.625	25.4	14	35	28	7	28	7.8	3
13250R		13250L		250	237.3	200	63	47.625	25.4	14	35	36	9	36	12.6	3
13315R		13315L		315	302.3	240	80	47.625	25.4	14	35	44	11	44	20.2	4

Inserts are not included.

Body (GFX 13000)

Imperial

Cat. No. (R)	Stock	Cat. No. (L)	Stock	Dimensions (mm)								Total Teeth	No. of Finishing Edges	Effective Teeth	Weight (kg)	Fig
				ϕD_c	ϕD_e	ϕD_b	L_f	ϕd	a	b	ℓ					
GFX 16080R		GFX 16080L		*80	64.1	60	50	25.4	9.5	6	25	8	2	8	1.4	1
16100R	●	16100L		100	84.1	70	50	31.75	12.7	8	32	12	3	12	1.9	2
16125R	●	16125L		125	109.1	80	63	38.1	15.9	10	38	16	4	16	3.3	2
16160R	●	16160L		160	144.1	120	63	50.8	19.1	11	38	20	5	20	6.4	2
16200R	●	16200L		200	184.1	150	63	47.625	25.4	14	35	28	7	28	7.8	3
16250R		16250L		250	234.1	200	63	47.625	25.4	14	35	36	9	36	12.6	3
16315R		16315L		315	299.1	240	80	47.625	25.4	14	35	44	11	44	20.2	4

Inserts are not included.



*Please use hexagonal bolt (JISB1176) M12 x 30-35 mm for securing $\phi 80$ cutter to the arbour.

Inserts

P Steel **M** Stainless Steel **K** Cast Iron **N** Non-Ferrous Metal **S** Exotic Alloy **H** Hardened Steel

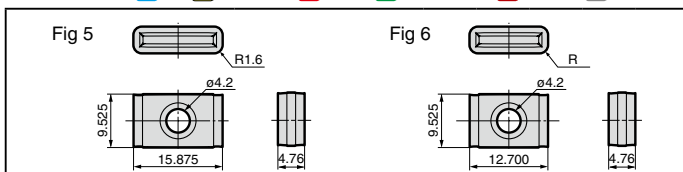

Grade		Coated Carbide	Carbide	Fig		
Application	High Speed/Light	K	K			
	General Purpose	K				
	Roughing	K	K			
Cat. No.		ACK260	ACK280	ACK300	H10E	
LNGX 160516PNFN-W		●	●		●	5
LNGX 130508PNFN-W		●	●		●	6
130516PNFN-W		●	●		●	6

Application Examples

H135

Recommended Cutting Conditions

ISO	Work Material	Hardness	Cutting Speed V_c (m/min) Min. - Optimum - Max.	Feed Rate f_z (mm/t) Min. - Optimum - Max.	Grade
K	Cast Iron	250HB	200-250-350	0.15-0.33-0.50	ACK260

Note Calculate cutting conditions based on effective teeth.

Spare Parts

Cartridge (For 16000 Type)	Cartridge (For 13000 Type)	Fine adjustment screw	Spanner	Insert Screw	Spanner (For Adjustment)	Cartridge Screw	Cartridge Screw	Spanner (For Cartridges)	Anti-seizure Cream	
GFVK5R/L	GFVK4R/L	BTD05F09	TTX15W	BFTX03588	3.0	LT15	BX0414	BX0418	TH030	SUMI-P

Recommended Tightening Torque (N·m)

*Finishing cartridges do not come assembled with inserts.

Rake Angle	Radial	-1.1°
	Axial	-3°



P	M	K	N	N	S	H
Steel	Stainless Steel	Cast Iron	Non-Ferrous Metal	Aluminum	Exotic Alloy	Hardened Steel
×	×	×	×	×	×	×

High Feed Finishing/Shoulder Milling Of Cast Iron



Fig 1

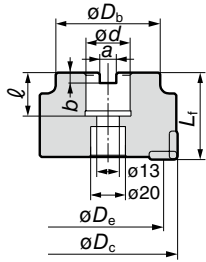
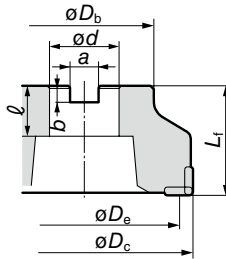

Fig 2



Body Imperial

Cat. No. (R)	Stock	Cat. No. (L)	Stock	Dimensions (mm)								Total Teeth	No. of Finishing Edges	Effective Teeth	Weight (kg)	Fig
				ϕD_c	ϕD_e	ϕD_b	L_f	ϕd	a	b	ℓ					
GFS 13080R		GFS 13080L		*80	66.9	60	50	25.4	9.5	6	25	5	1	4	1.4	1
13100R		13100L		100	86.9	70	50	31.75	12.7	8	32	6	1	5	1.9	2
13125R		13125L		125	111.9	80	63	38.1	15.9	10	38	8	2	6	3.3	2
13160R		13160L		160	147.3	120	63	50.8	19.1	11	38	10	2	8	6.4	2



Inserts are not included.
*Please use hexagonal bolt (JISB1176) M12 x 30-35 mm for securing $\phi 80$ cutter to the arbour.

Inserts P Steel M Stainless Steel K Cast Iron N Non-Ferrous Metal S Exotic Alloy H Hardened Steel

Grade		Coated Carbide	Carbide
Application	High Speed/Light	K	K
	General Purpose	K	
	Roughing	K	K
Cat. No.		ACK260	ACK280 ACK300 H10E
LNGX 130508PNFN-W		●	●
130516PNFN-W		●	●

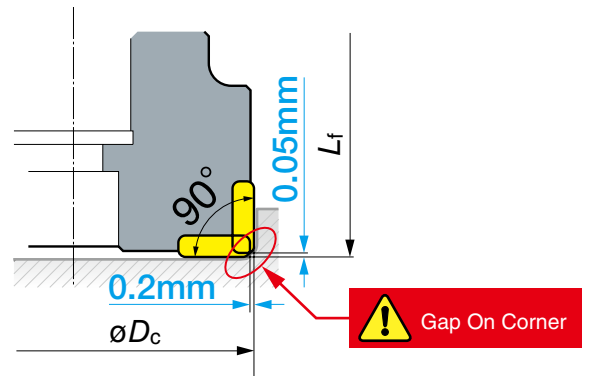

Spare Parts

Finishing Cartridge*	Fine adjustment screw	Spanner	Insert Screw	Spanner (For Adjustment)	Cartridge Screw	Spanner (For Cartridges)	Anti-seizure Cream	
GFSK4R/L	BTD05F09	TTX15W	BFTX03588	3.0	LT15	BX0520	TH040	SUMI-P

Recommended Tightening Torque (N·m)

*Finishing cartridges do not come assembled with inserts.

Recommended Cutting Conditions

ISO	Work Material	Hardness	Cutting Speed v_c (m/min) Min. - Optimum - Max.	Feed Rate f_z (mm/t) Min. - Optimum - Max.	Grade
K	Cast Iron	250HB	200-250-300	0.10-0.15-0.30	ACK260

Note Calculate cutting conditions based on effective teeth.

GSV16000 Type

Rake Angle	Radial	-14° to -6°
	Axial	-5°

8mm 65°

P	M	K	N	S	H
Steel	Stainless Steel	Cast Iron	Non-Ferrous Metal	Exotic Alloy	Hardened Steel
×	×	×	×	×	×

Medium Finishing of Cast Iron



Fig 1

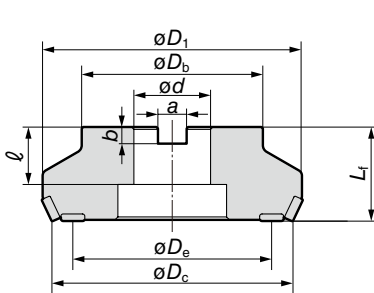

Fig 2

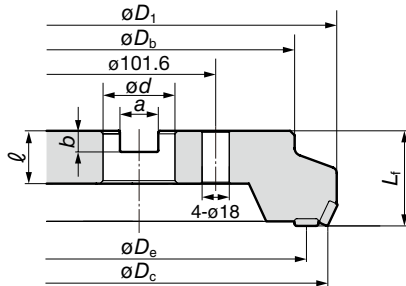
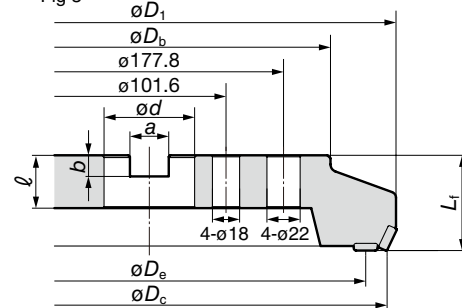

Fig 3



■ Body Imperial

Cat. No.(R)	Stock	Cat. No.(L)	Stock	Dimensions (mm)									Total Teeth	No. of Finishing Edges	Effective Teeth	Weight (kg)	Fig
				ϕD_c	ϕD_e	ϕD_1	ϕD_b	L_f	ϕd	a	b	ℓ					
GSV 16160R		GSV 16160L		192	160	206	120	63	50.8	19.1	11	38	20	2	18	9.8	1
16200R		16200L		232	200	246	150	63	47.625	25.4	14	35	28	4	24	11.0	2
16250R		16250L		282	250	296	200	63	47.625	25.4	14	35	34	4	30	18.3	2
16315R		16315L		347	315	361	240	80	47.625	25.4	14	35	40	4	36	28.5	3

Inserts are not included.

■ Inserts P Steel M Stainless Steel K Cast Iron N Non-Ferrous Metal S Exotic Alloy H Hardened Steel

Fig 4

Fig 5 Wiper Insert

Grade		Coated Carbide					Fig
Application	High Speed/Light	K	K	K			
	General Purpose	K	K	K			
	Roughing				K	K	
Cat. No.		ACK100	ACK200	ACK260	ACK280	ACK300	
LNMX 160608PNSN-G			●			●	4
160608PNSN-H		●	●			●	4
LNGX 160516PNFN-W				●	●		5

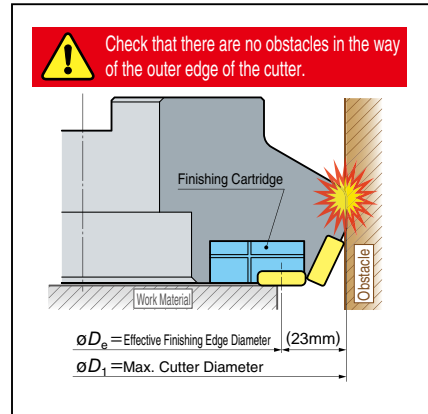

■ Application Examples

H135

■ Spare Parts

Finishing Cartridge*	Fine adjustment screw	Screw (For Finishing Inserts)	Cartridge Screw	Screw (For Roughing Edge Inserts)	Spanner	Spanner	Spanner (For Fine Adjustment)	Anti-seizure Cream	Recommended Tightening Torque (N·m)	
GSVK5R/L	BTD05F09	BFTX03588	3.0	BX0612	BFTX0412N	3.0	TTX15W	TH050	LT15	SUMI-P

*Finishing cartridges do not come assembled with inserts.

■ Recommended Cutting Conditions

ISO	Work Material	Hardness	Cutting Speed v_c (m/min) Min. - Optimum - Max.	Feed Rate f_z (mm/t) Min. - Optimum - Max.	Grade
K	Cast Iron	250HB	200-250-300	0.15-0.23-0.30	ACK200 ACK300

Note Calculate cutting conditions based on effective teeth.

Rake Angle	Radial	-14° to -6°	 45°	<table border="1"> <tr> <td>P</td><td>M</td><td>K</td><td>N</td><td>S</td><td>H</td> </tr> <tr> <td>Steel</td><td>Stainless Steel</td><td>Cast Iron</td><td>Non-Ferrous Metal</td><td>Exotic Alloy</td><td>Hardened Steel</td> </tr> </table>	P	M	K	N	S	H	Steel	Stainless Steel	Cast Iron	Non-Ferrous Metal	Exotic Alloy	Hardened Steel
	P	M			K	N	S	H								
Steel	Stainless Steel	Cast Iron	Non-Ferrous Metal	Exotic Alloy	Hardened Steel											
Axial		-5°														

High Feed Roughing for Cast Iron

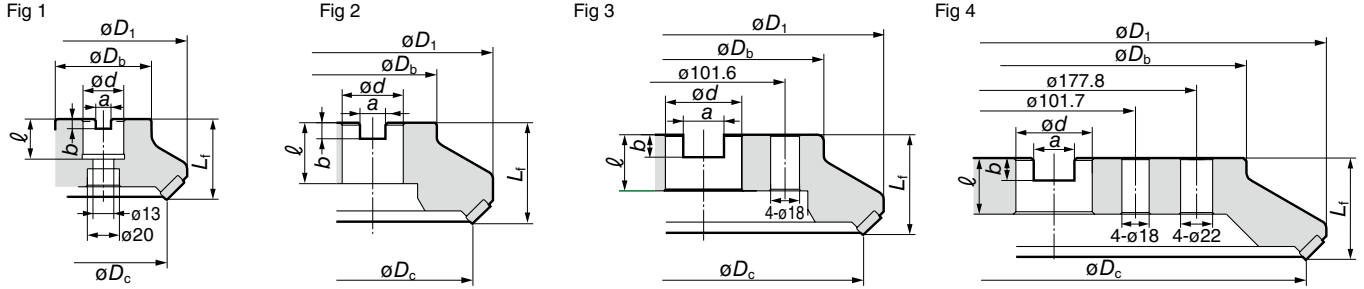

Body Imperial

Cat. No.(R)	Stock	Cat. No.(L)	Stock	Dimensions (mm)								No. of Teeth	Weight (kg)	Fig
				ϕD_c	ϕD_1	ϕD_b	L_f	ϕd	a	b	l			
GRV 16080R		GRV 16080L		*80	104	60	50	25.4	9.5	6	25	9	1.9	1
16100R		16100L		100	124	70	50	31.75	12.7	8	32	12	3.2	2
16125R		16125L		125	149	80	63	38.1	15.9	10	38	15	4.3	2
16160R		16160L		160	184	120	63	50.8	19.1	11	38	18	5.7	2
16200R		16200L		200	225	150	63	47.625	25.4	14	35	24	8.1	3
16250R		16250L		250	275	200	63	47.625	25.4	14	35	30	13.5	3
16315R		16315L		315	340	240	80	47.625	25.4	14	35	36	21.6	4

Inserts are not included.



*Please use hexagonal bolt (JISB1176) M12 x 30-35 mm for securing $\phi 80$ cutter to the arbour.

Insert

P Steel **M** Stainless Steel **K** Cast Iron **N** Non-Ferrous Metal **S** Exotic Alloy **H** Hardened Steel

General Purpose G-Type
Fig 5

Strong Edge H Type
Fig 6

Grade		Coated Carbide			Application	Remarks	Fig
Application	High Speed/Light	K	K				
	General Purpose	K	K				
	Roughing			K			

Cat. No.	ACK100	ACK200	ACK300	Application	Remarks	Fig
LNMX 160608PNSN-G		●	●	General Purpose	Recommended	5
160608PNSN-H	●	●	●	Heavy interrupted cutting and other unstable applications		6

Spare Parts

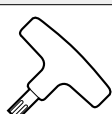
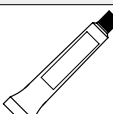
Screw	Wrench	Anti-seizure Cream
		
BFTX0412N 3.0	TTX15W	SUMI-P

 Recommended Tightening Torque (N · m)

Recommended Cutting Conditions

ISO	Work Material	Hardness	Cutting Speed v_c (m/min) Min. - Optimum - Max.	Feed Rate f_z (mm/t) Min. - Optimum - Max.	Grade
K	Cast Iron	250HB	200-250-300	0.15-0.23-0.30	ACK200 ACK300

Note Calculate cutting conditions based on effective teeth.

H Milling Cutters (Special Purpose) GOAL MILL HIGH FEED Quick Change

High-Feed Facemills

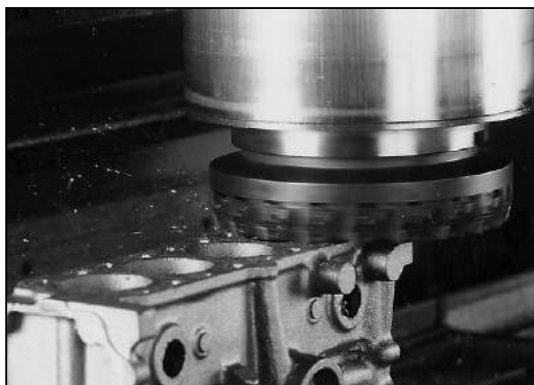

General Features

Sumitomo Electric Hardmetal SEC-High Feed facemills make high performance milling particularly suited for cast irons, aluminium and exotic materials. Edge reference system design is rugged, simple and easy to maintain.

Characteristics

- Unique design for high speed, high feed machining.
- Edge reference system provides simple, easy and fast insert indexing. (→ H104)
- Cutter design makes it ideal for use on low-horsepowered machines with high performance.
- An excellent range of cutter designs and insert grades to suit various applications.
- Quick change system provides fast setting on the machine. (→ H146)

	Cat. No.	Specifications	Applicable Cutter Size
(1)	F type/NF type*	Quick Change System	ø160mm or less
(2)	2 piece type	2 piece set indication	ø200mm or more
(3)		2 piece with centre bolt	

* The Quick Change System NF type is a made-to-order item. For details, please

Specifications

Applicable Cutter		Cat. No.	A.A. & Max D.O.C. (5000 Type)	Rake Angle		Cutter Insert	Page
Application	Surface Roughness			Axial Rake	Radial Rake		
Rough	25S	NRV 4000 Type		-5°	-6°	SNC43MW	H146
		NRV 5000 Type				SNC535	
Roughing / Finishing	18S	DPV 4000 Type		+10°	+5°	SDCN42R/L	H146
		DPV 5000 Type				SDCN53R/L	
Finishing	12.5S	NFV 4000 Type		-5°	-6°	6SS43M	H146
		NFV 5000 Type				6SS53M	
Roughing / Finishing of Non-Ferrous Alloy	12.5S	APV 5000 Type		+18°	-2°	SDC53R/L	H146

Recommended Conditions

Cat. No.	Insert	Grade	Cutting Conditions (Min. - Optimum - Max.)		
			v_c (m /min)	f_z (mm/t)	a_p (mm)
NRV 4000 Type	SNC43MW	ACK200	80 - 100 - 120	0.1 - 0.15 - 0.2	Up to 3
NRV 5000 Type	SNC535	ACK200	80 - 100 - 120	0.1 - 0.15 - 0.2	Up to 3
DPV 4000 Type	SDCN42R/L	G10E	80 - 100 - 120	0.1 - 0.15 - 0.2	Up to 3
DPV 5000 Type	SDCN53R/L	G10E	80 - 100 - 120	0.1 - 0.15 - 0.2	Up to 5
NFV 4000 Type	6SS43M	H10E	120 - 160 - 200	0.1 - 0.15 - 0.2	Up to 0.5
NFV 5000 Type	6SS53M	H10E	120 - 160 - 200	0.1 - 0.15 - 0.2	Up to 0.5
APV 5000 Type	SDC53R/L	H1	< 400	0.1 - 0.20 - 0.3	Up to 3

H
 Milling Cutters
 (Special Purpose)
 GOAL MILL
 HIGH FEED
 Quick Change

Cutting Edge Reference System



General Features

Conventional milling cutters are designed with several parts to locate and clamp each insert. The edge reference system on the other hand, utilises only one part for the same purposes. (Refer to Fig.1) This system is adopted by our entire high-feed cutter series.

Characteristics

- Axial run-out of the inserts is kept within 5 to 10 μ m to ensure fine surface finish and longer too life.
- Simple design with fewer parts facilitates cleaning of cutter body and is comparatively inexpensive.
- Fewer parts allow for high-density cutter design, for higher efficiency and longer too life.

Fig. 1

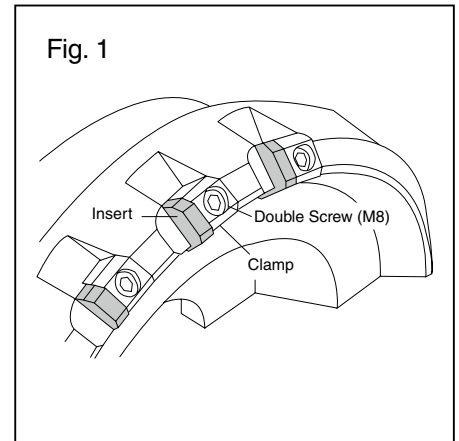

Assembly Jig

Application of the special assembly jig (as shown in the figure below) is recommended to accurately assemble the cutter.

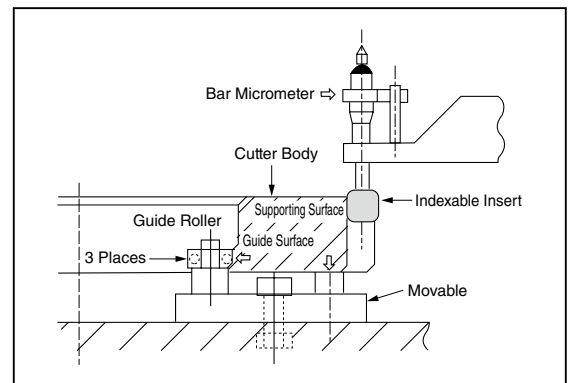
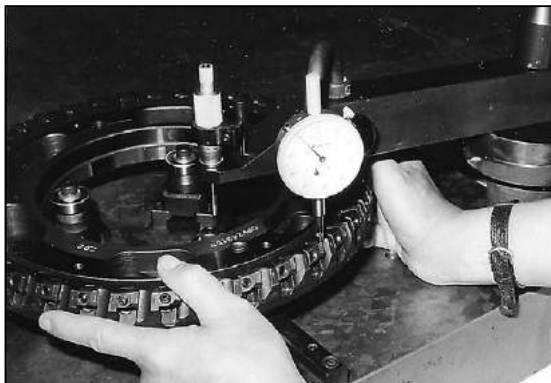

Setting Inserts

When setting the inserts, please pay careful attention to the points noted below in the coloured boxes .

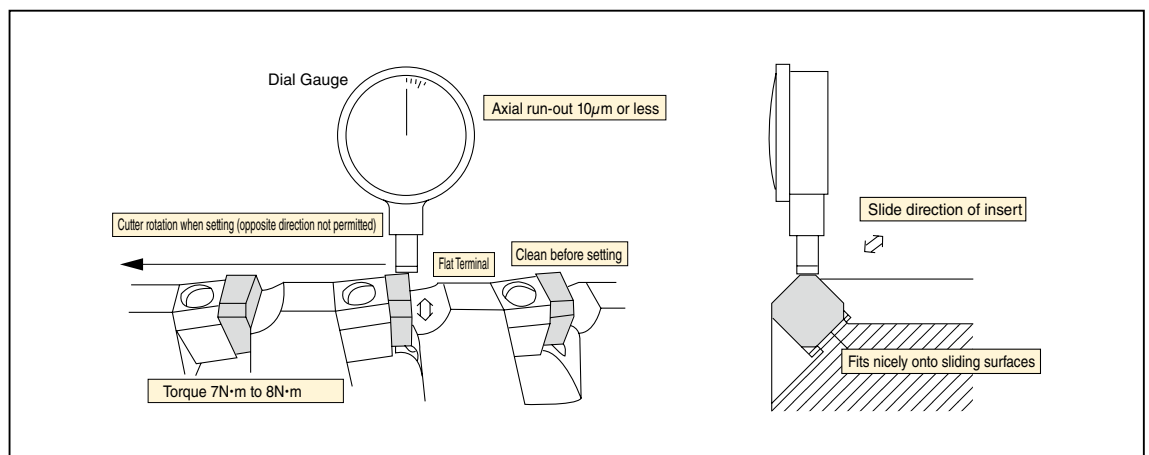

SEC-High-Feed Mill NRV4000/5000 Type

High Feed Roughing Of
Cast Iron

Recommended Cutting Conditions
→ H142

P	M	K	N	S	H
Steel	Stainless Steel	Cast Iron	Non-Ferrous Metal	Exotic Alloy	Hardened Steel
X	X	X	X	X	X

Rake Angle	Radial	-6°
	Axial	-5°

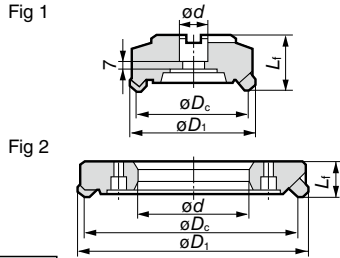

■ Milling Cutter Body Imperial

Inserts are not included.

Type	Cat. No.	Stock		Dimensions (mm)				No. of Teeth	Weight (kg)	Fig
		R	L	ϕD_c	ϕD_1^*	ϕd	L_1			
F Type	NRV ϕ 100QR/L	100		112(118)	31.75	60	10	2.7	1	
	ϕ 125QR/L	125		137(143)	38.1	60	14	3.8	1	
	ϕ 160QR/L	160		172(177)	50.8	60	18	6.3	1	
Two Piece Type	NRVZ ϕ 200R/L	200		212(218)	80	40	24	5.8	2	
	ϕ 250R/L	250		262(268)	120	40	30	9.0	2	
	ϕ 315R/L	315		326(332)	180	40	36	12.5	2	
	ϕ 355R/L	355		366(372)	220	40	42	15.5	2	
	ϕ 400R/L	400		411(417)	250	40	48	18.8	2	
	ϕ 450R/L	450		461(467)	300	40	54	22.0	2	

- * 4 or 5 must be filed in "O".
- Refer to page H146 for special arbour for Fig. 1 type cutters.
- Refer to page H146 for special adaptor for Fig. 2 type cutters.
- *: Dimensions in parentheses are for 5000 Type.

■ Insert

P Steel M Stainless Steel K Cast Iron N Non-Ferrous Metal S Exotic Alloy H Hardened Steel

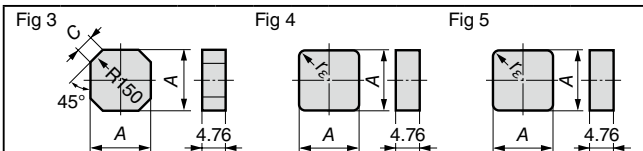

Application	Grade	Coated Carbide		Carbide	Dimensions (mm)			Fig	Applicable Cutters
		High Speed/Light	General Purpose		A	C	r_ϵ		
High Feed	High Speed/Light	K							
	General Purpose	K		K					
	Roughing		K						
Cat. No.		ACK200	ACK300	G10E					
					A	C	r_ϵ	Fig	Applicable Cutters
	SNC 43MW			●	12.70	3.0	—	3	NRV4000
	SNC 433				12.70	—	1.2	4	NRV4000
	434				12.70	—	1.6	4	NRV4000
	435				12.70	—	2.0	4	NRV4000
	436				12.70	—	2.4	4	NRV4000
	SNC 535				15.875	—	2.0	4	NRV5000
	SNMN 432			●	12.70	—	0.8	5	NRV4000
	433		●	●	12.70	—	1.2	5	NRV4000
	434				12.70	—	1.6	5	NRV4000
	435				12.70	—	2.0	5	NRV4000
	436				12.70	—	2.4	5	NRV4000

■ Spare Parts

Clamp		Double Screw	Spanner	Applicable Cutters	The above cutters must be used with:
Below ϕ 160	Above ϕ 200				
NW41RR	NW42RR	WB6-20	TH030	NRV4000R	• Arbour for F Type • 2 Pc Type Adaptor
NW41RL	NW42RL			NRV4000L	
NW51R	NW52R	WV6-20	TH030	NRV5000R	
NW51L	NW52L			NRV5000L	

SEC-High-Feed Mill DPV4000/5000 Type

High Feed Medium Finishing Of
Cast Iron

Recommended Cutting Conditions
→ H142

P	M	K	N	S	H
Steel	Stainless Steel	Cast Iron	Non-Ferrous Metal	Exotic Alloy	Hardened Steel
X	X	X	X	X	X

Rake Angle	Radial	+5°
	Axial	+10°

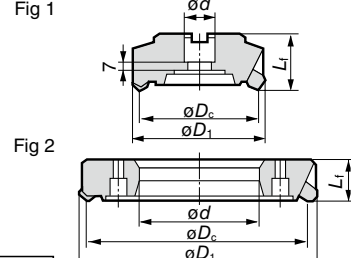
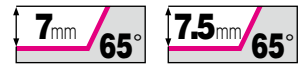

■ Milling Cutter Body Imperial

Inserts are not included.

Type	Cat. No.	Stock		Dimensions (mm)				No. of Teeth	Weight (kg)	Fig
		R	L	ϕD_c	ϕD_1^*	ϕd	L_1			
F Type	DPV ϕ 100QR/L	100		107.2(109.6)	31.75	60	12	10	2.6	1
	ϕ 125QR/L	125		131.5(133.6)	38.1	60	16	14	3.6	1
	ϕ 160QR/L	160		165.8(176.6)	50.8	60	20	18	6.0	1
Two Piece Type	DPVZ ϕ 200R/L	200		206.5(208)	80	40	26	24	5.5	2
	ϕ 250R/L	250		256 (258)	120	40	32	30	9.0	2
	ϕ 315R/L	315		322.5(323)	180	40	38	36	12.0	2
	ϕ 355R/L	355		361.5(363)	220	40	44	42	15.0	2
	ϕ 400R/L	400		406.5(408)	250	40	50	48	17.8	2
	ϕ 450R/L	450		456.5(458)	300	40	56	54	20.8	2

- * 4 or 5 must be filed in "O".
- Refer to page H146 for special arbour for Fig. 1 type cutters.
- Refer to page H146 for special adaptor for Fig. 2 type cutters.
- *: Dimensions in parentheses are for 5000 Type.

■ Insert

P Steel M Stainless Steel K Cast Iron N Non-Ferrous Metal S Exotic Alloy H Hardened Steel

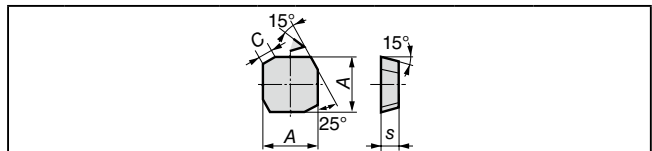

Application	Grade	Coated Carbide		Carbide	Dimensions (mm)			Applicable Cutters
		High Speed/Light	General Purpose		A	s	C	
High Feed	High Speed/Light	K		K				
	General Purpose	K						
	Roughing		K					
Cat. No.		ACK200	ACK300	H10E				
					A	s	C	Applicable Cutters
	SDCN 42R			●	12.70	3.18	3.5	DPV4000R
	42L			●	12.70	3.18	3.5	DPV4000L
	SDCN 53R			●	15.875	5.0	5.0	DPV5000R
	53L			●	15.875	5.0	5.0	DPV5000L

■ Spare Parts

Clamp		Double Screw	Spanner	Applicable Cutters	The above cutters must be used with:
Below ϕ 160	Above ϕ 200				
HTW40R	HTW41R	WB6-20	TH030	DPV4000R	• Arbour for F Type • 2 Pc Type Adaptor
HTW40L	HTW41L			DPV4000L	
HTW50R	HTW51R	WB6-20	TH030	DPV5000R	
HTW50L	HTW51L			DPV5000L	

NFV 4000/5000 Type

High Feed Finishing Of Cast Iron

Recommended Cutting Conditions	P Steel	M Stainless Steel	K Cast Iron	N Non-Ferrous Metal	S Exotic Alloy	H Hardened Steel
→ H142	X	X	X	X	X	X

Rake Angle	Radial	-6°
	Axial	-5°

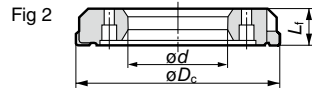
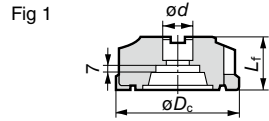

Milling Cutter Body Imperial

Inserts are not included.

Type	Cat. No.	Stock		Dimensions (mm)				No. of Teeth	Weight (kg)	Fig
		R	L	ϕD_c	ϕd	L_f				
F Type	NFV ϕ 100QR/L			100	31.75	60	10	2.6	1	
	ϕ 125QR/L			125	38.1	60	14	3.9	1	
	ϕ 160QR/L			160	50.8	60	18	6.3	1	
Two Piece Type	NFV ϕ 200R/L			200	80	40	24	5.3	2	
	ϕ 250R/L			250	120	40	30	9.0	2	
	ϕ 315R/L			315	180	40	36	11.3	2	
	ϕ 355R/L			355	220	40	42	14.0	2	
	ϕ 400R/L			400	250	40	48	16.5	2	
	ϕ 450R/L			450	300	40	54	21.0	2	

- 4 or 5 must be filed in "O".
- Refer to page H146 for special arbour for Fig. 1 type cutters.
- Refer to page H146 for special adaptor for Fig. 2 type cutters.

Insert

P Steel **M** Stainless Steel **K** Cast Iron **N** Non-Ferrous Metal **S** Exotic Alloy **H** Hardened Steel

Grade		Carbide	Dimensions (mm)			Applicable Cutters
Application	High Speed/Light	K	A	s	Fig	
Application	High Speed/Light	K				
	General Purpose					
	Roughing					
Cat. No.	H/D		A	s	Fig	Applicable Cutters
SNEF 43W	●		12.70	4.76	3	NFV4000
6SS 43M	●		12.70	4.76	4	NFV4000
SNEF 53W	●		15.875	4.76	3	NFV5000
53WT	●		15.875	4.76	3	NFV5000
6SS 53M	●		15.875	4.76	4	NFV5000
SNEN 535W			15.875	4.76	5	NFV5000

Spare Parts

			Applicable Cutters	The above cutters must be used with:
Clamp	Double Screw	Spanner		
Below ϕ 160	Above ϕ 200			
NW41FR	NW42FR	WB6-20	TH030	• Arbour for F Type
NW41FL	NW42FL			
NW51R	NW52R	WB6-20	TH030	• 2 Pc Type Adaptor
NW51L	NW52L			

APV 5000 Type

High Feed Medium Finishing Of Non-Ferrous Alloy/Thin Work Pieces

Recommended Cutting Conditions	P Steel	M Stainless Steel	K Cast Iron	N Non-Ferrous Metal	S Exotic Alloy	H Hardened Steel
→ H142	X	X	X	X	X	X

Rake Angle	Radial	-2°
	Axial	+18°

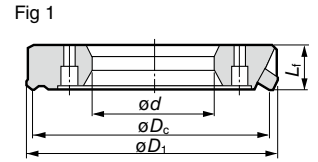

Milling Cutter Body

Inserts are not included.

Type	Cat. No.	Stock		Dimensions (mm)				No. of Teeth	Weight (kg)	Fig
		R	L	ϕD_c	ϕD_1	ϕd	L_f			
Two Piece Type	APVZ 5200R/L			200	211	80	40	18	7.0	1
	5250R/L			250	261	120	40	22	10.8	1
	5315R/L			315	326	180	40	26	13.7	1
	5355R/L			355	366	220	40	32	16.3	1
	5400R/L			400	411	250	40	36	20.0	1
	5450R/L			450	461	300	40	40	23.6	1

Insert

P Steel **M** Stainless Steel **K** Cast Iron **N** Non-Ferrous Metal **S** Exotic Alloy **H** Hardened Steel

Grade		Carbide	Cermet	Dimensions (mm)			Applicable Cutters
Application	High Speed/Light	K		A	s	C	
Application	High Speed/Light	K					
	General Purpose	P					
	Roughing						
Cat. No.	A30N	H	T250A	A	s	C	Applicable Cutters
SDC 53R		●		15.88	4.76	2.5	APV5000R
53L		●		15.88	4.76	2.5	APV5000L
53TR		●		15.88	4.76	2.5	APV5000R
53TL				15.88	4.76	2.5	APV5000L
53TR-R				15.88	4.76	2.5	APV5000R
SDCH 53TR		●		15.88	4.76	2.5	APV5000R
53TR-R				15.88	4.76	2.5	APV5000R

Spare Parts

			Applicable Cutters	The above cutters must be used with:
Clamp	Double Screw	Spanner		
Above ϕ 200				
AW52R	WB6-20	TH030	APV5000R	• 2 Pc Type Adaptor
AW52L			APV5000L	

QC System for High-feed Facemills

Quick-F Series

Structure

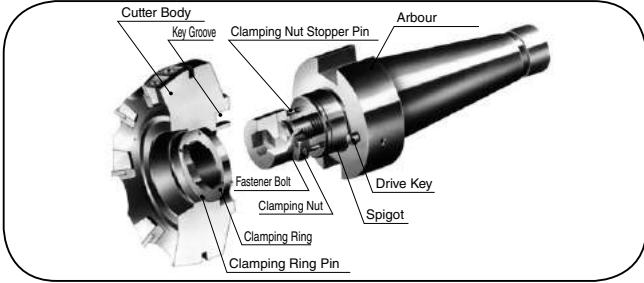

Arbour

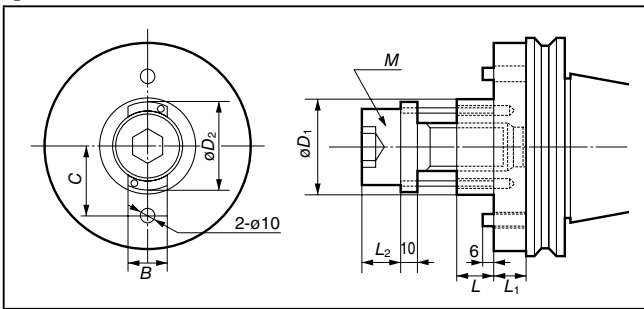

Cat. No.	Dimensions (mm)							
	ϕD_1	ϕD_2	M	B	L	L_1	L_2	C
○○○○ QF4R/L	31.75	30.75	M14 P2.0	18	22	22	13	27.5
○○○○ QF5R/L	38.10	37.10	M16 P2.0	20	20	24	14	27.5
○○○○ QF6R/L	50.80	49.80	M20 P2.5	24	20	30	16	34

Taper code must be filed in " ° ". (Ex. BT50-QF4R)

Features

- (1) Requires less time for mounting and removing.
- (2) Applicable to cutter diameters 4" ($\phi 100$) to 6" ($\phi 160$).

Quick-NF Series (Applicable to cutter diameters 3" ($\phi 80$) to 6" ($\phi 160$))

*Made-to-order product. Please contact us directly when ordering.

Arbour

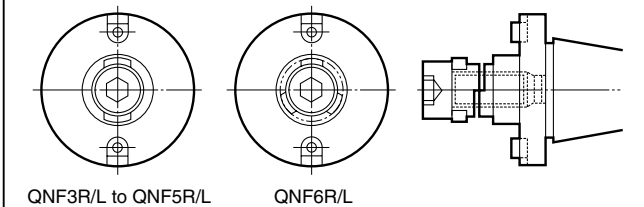

Cutter

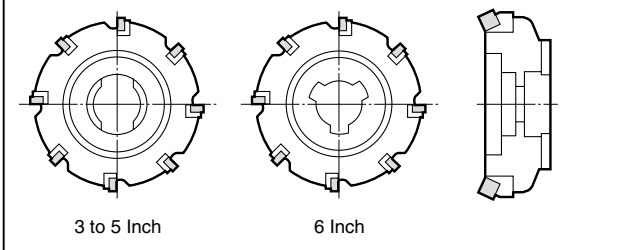

Two Piece Cutter

Appearance



Adaptor

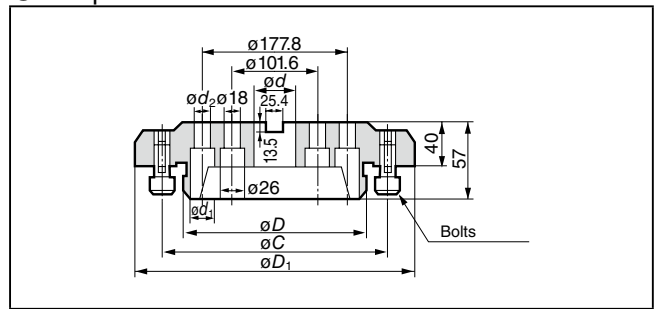

Cat. No.	Dimensions (mm)						No. of Bolts	Cutter Size (mm)
	ϕD	ϕD_1	ϕd	ϕd_1	ϕd_2	ϕC		
QAD 200	80	180	47.625	—	—	120	4	$\phi 200$
250	120	230	47.625	—	—	170	4	$\phi 250$
315	180	295	47.625	32	22	230	6	$\phi 315$
355	220	335	63.50	32	22	270	6	$\phi 355$
400	250	370	63.50	32	22	300	6	$\phi 400$
450	300	420	63.50	32	22	350	6	$\phi 450$

Features

- (1) Light weight ring cutter body.
- (2) Cutter changing function without removing bolt.
- (3) Tapered spline system is used to connect the adaptor to the cutter.
- (4) Applicable to cutters over $\phi 200$.
- (5) Effective when mounting several cutter body sizes on the same adaptor.

Cutter Mounting Diagram

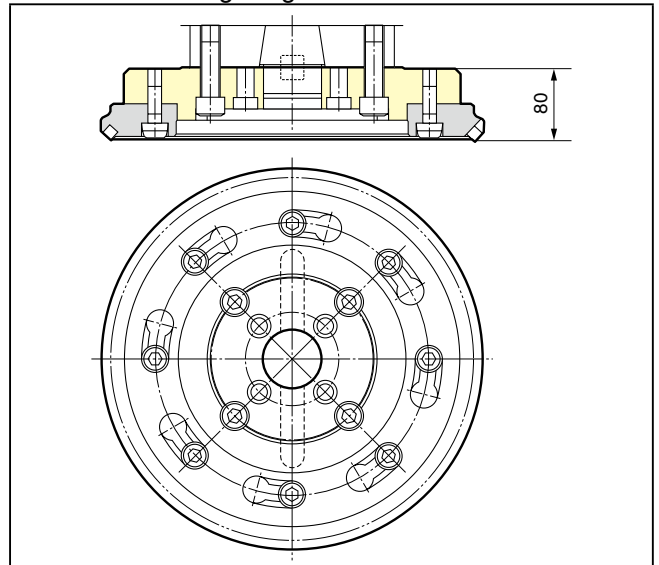

H
Milling Cutters (Special Purpose)
GOAL MILL
HIGH FEED
Quick Change

Two Piece Cutter With Centre Bolt

Appearance

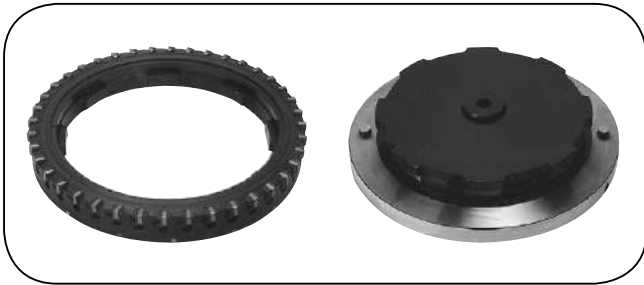

Adaptor

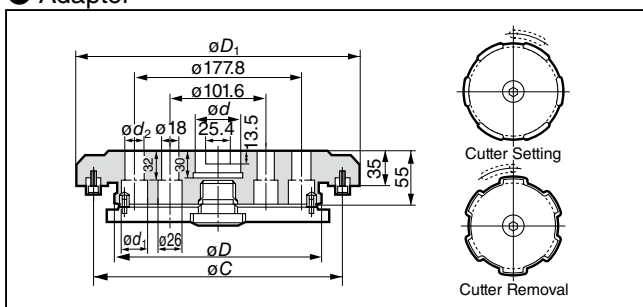

Cat. No.	Dimensions (mm)						Cutter Size (mm)
	ϕD	ϕD_1	ϕd	ϕd_1	ϕd_2	ϕC	
NQAD 200	105	180	47.625	—	—	155	$\phi 200$
250	155	240	47.625	—	—	205	$\phi 250$
315	220	305	47.625	32	22	270	$\phi 315$
355	260	345	63.50	32	22	310	$\phi 355$
400	305	390	63.50	32	22	355	$\phi 400$
450	355	440	63.50	32	22	405	$\phi 450$

Features

- (1) With one clamping bolt, total weight of cutter is relatively lighter.
- (2) Quick mounting.
- (3) Tapered spline system is used to connect the adaptor to the cutter.
- (4) Applicable to cutters over $\phi 200$.

Cutter Mounting Diagram

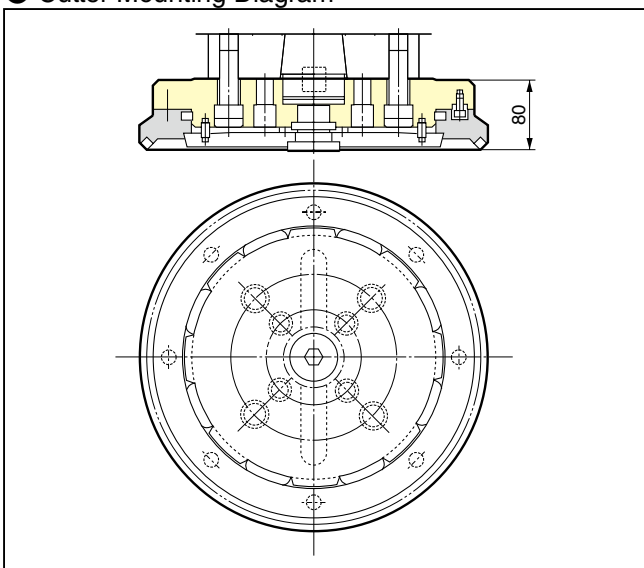

Quick-F QF Type Cutter

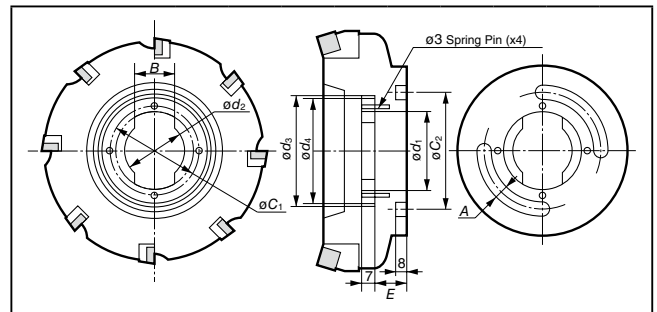

Cutter Size (mm)	Dimensions (mm)								
	ϕd_1	ϕd_2	ϕd_3	ϕd_4	ϕC_1	ϕC_2	A	B	E
$\phi 100$	31.75	22	43.75	43.5	37.75	55	12	20	24
$\phi 125$	38.10	29	50.10	49.8	44.10	55	12	22	22
$\phi 160$	50.80	41	62.80	62.5	56.80	68	12	26	22

* This design applies to all F type high feed cutters (\rightarrow H144 to H145).
* Conventional cutter can be easily adapted to quick change through slight modification.

QAD Cutter (Two Piece Type)

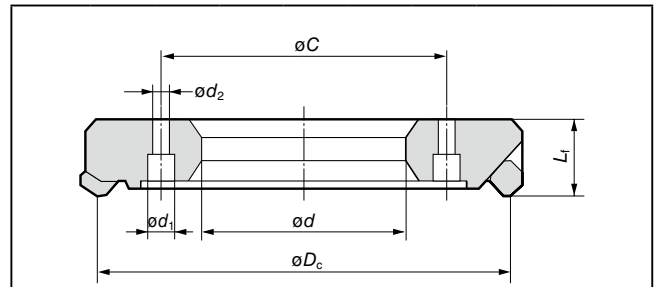

Cutter Size (mm)	Dimensions (mm)						No. of Bolts	Adaptor Cat. No.
	ϕD_c	ϕd	ϕd_1	ϕd_2	ϕC	L_f		
$\phi 200$	200	80	24	14	120	40	4	QAD200
$\phi 250$	250	120	30	18	170	40	4	QAD250
$\phi 315$	315	180	30	18	230	40	6	QAD315
$\phi 355$	355	220	30	18	270	40	6	QAD355
$\phi 400$	400	250	30	18	300	40	8	QAD400
$\phi 450$	450	300	30	18	350	40	8	QAD450

* This design applies to all two piece type high feed cutters (\rightarrow H144 to H145).

NQAD Cutter (Two Piece Type With Centre Bolt)

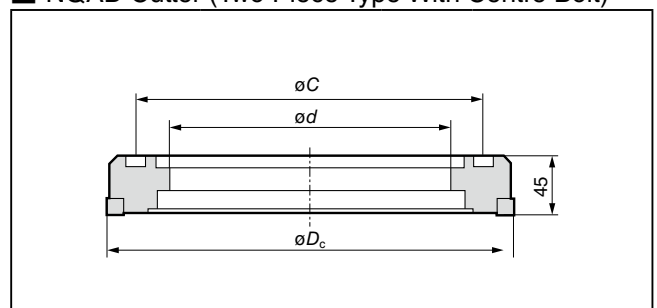

Cutter Size (mm)	Dimensions (mm)			Adaptor Cat. No.
	ϕD_c	ϕd	ϕC	
$\phi 200$	200	105	155	NQAD200
$\phi 250$	250	155	205	NQAD250
$\phi 315$	315	220	270	NQAD315
$\phi 355$	355	260	310	NQAD355
$\phi 400$	400	305	355	NQAD400
$\phi 450$	450	355	405	NQAD450

* This design applies to all two piece with centre bolt type high feed cutters (\rightarrow H144 to H145).