

# Boring Bars

# E

## E1 to E77



SEC-Boring Tool Series .....	E2
Boring Tools Identification Table .....	E4
Boring Bar Selection Guide .....	E5
Multi-functional Autolathe Tool, Twin Head Holder .....	E10















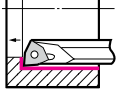

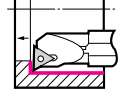
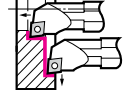
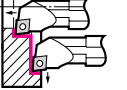
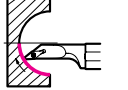
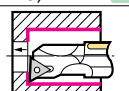
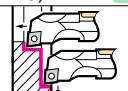
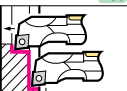

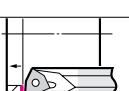
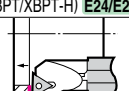
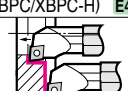
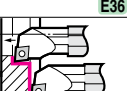
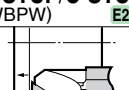

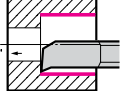
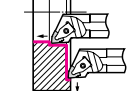

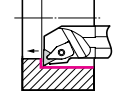

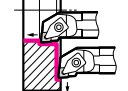
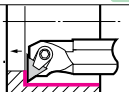
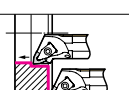
<b>Minimal Boring</b>	SEC-Mini Boring Tool	<b>CKB Type</b> .....	E12
	Solid Carbide Bar	<b>BXBR Type</b> .....	E16
	SUMIDIA Small Hole Boring Bars	<b>DABB Type</b> .....	E17
<b>Stop Boring</b>	SUMIBORON Small Hole Boring Bars	<b>BSME Type</b> .....	E18
		<b>SEXC Type</b> .....	E19
		<b>BNBX Type / BNB Type</b> .....	E20
	SEC-Boring Bar	<b>S-SWUB Type / C-SWUB Type</b> .....	E21
		<b>S-SWUP Type</b> .....	E23
		<b>S-STUP Type / S-STUB Type / B-STUP Type</b> .....	E24
		<b>D-STUP Type / C-STUP Type / C-STUB Type</b> .....	E25
		<b>E-STUP Type</b> .....	E26
		<b>S-CTFP Type</b> .....	E31
		<b>S-PTFN Type / B-PTFN Type</b> .....	E33
		<b>S-DTFN Type / D-DTFN Type</b> .....	E34
		<b>S-ETFN Type</b> .....	E35
	<b>Bottom Facing</b>	SUMIBORON Small Hole Boring Bars	<b>BNZ Type</b> .....
SEC-Boring Bar		<b>S-SCLC Type / B-SCLC Type</b> .....	E36
		<b>C-SCLC Type / E-SCLC Type</b> .....	E37
		<b>S-SCLP Type / B-SCLP Type / D-SCLP Type</b> .....	E42
		<b>C-SCLP Type</b> .....	E43
		<b>S-DCLN Type / D-DCLN Type</b> .....	E45
		<b>S-PCLN Type / B-PCLN Type</b> .....	E46
		<b>S-ECLN Type / D-DWLN Type</b> .....	E47
		<b>S-DWLN Type / S-PWLN Type</b> .....	E48
<b>Copying</b>		SEC-Boring Bar	<b>S-SDUC Type / B-SDUC Type / C-SDUC Type</b> .....
		<b>S-SDQC Type / B-SDQC Type</b> .....	E50
		<b>S-SDZC Type</b> .....	E51
		<b>S-SVJB Type / B-SVJB Type / S-SVJC Type</b> .....	E55
		<b>S-SVQB Type / B-SVQB Type / C-SVQB Type</b> .....	E56
		<b>S-SVQC Type / S-SVUB Type</b> .....	E57
		<b>B-SVUB Type / C-SVUB Type / S-SVUC Type</b> .....	E58
		<b>S-SVZB Type / B-SVZB Type / C-SVZB Type</b> .....	E59
		<b>S-SVZC Type</b> .....	E60
		<b>S-DDQN Type / S-DDUN Type / D-DDUN Type</b> .....	E65
		<b>S-PDUN Type / S-EDUN Type</b> .....	E66
		<b>S-PDZN Type / S-EDZN Type</b> .....	E67
		<b>S-DTR55C Type</b> .....	E67
	<b>MV Type / GD Type</b> .....	(C34, C35)	
<b>Through Boring</b>	SEC-Boring Bar	<b>S-SWUB Type / C-SWUB Type</b> .....	E68
		<b>S-SWUP Type</b> .....	E70
		<b>S-SSKP Type / C-SSKP Type</b> .....	E71
		<b>S-SSKC Type</b> .....	E72
		<b>S-CSKP Type</b> .....	E73
		<b>S-DSKN Type / S-PSKN Type</b> .....	E75
		<b>S-PSYN Type / S-ESKN Type / S-ESYN Type</b> .....	E76
	<b>Double Clamp Tool Holders</b>	<b>Clamp Set Parts</b> .....	E77

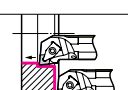
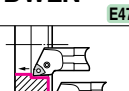
### Stock Indications and Symbols

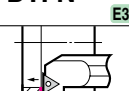
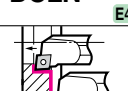
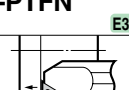
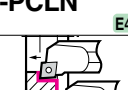
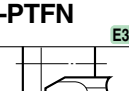
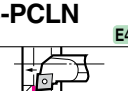
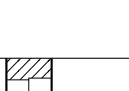
- mark: Standard stocked item
- mark: To be replaced by a new item featured on the same page
- ▲ mark: To be replaced by new item (Please confirm stock availability)

- \* mark: Semi-standard stock (Please confirm stock availability)
- mark: Stock or planned stock (Please confirm stock availability)
- No mark: Made-to-order item
- mark: We cannot produce

## Guide for Selection by Application

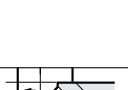
Application		Stop Boring		Bottom Facing		Spherical Internal Facing
Insert shape		Polygon  /Others	Trangle  /Others	80°Diamond 		35°Diamond 
System/Shank type						
Screw Lock	Steel	 S-SWUB (BBPW) E21 S-SWUP  E23	 S-STUP/S-STUB (BBPC) E24	 S-SCLP (BBPC) E42	 S-SCLC E36	 S-SVJB/S-SVJC E55
	Anti-vibration	—	 B-STUP/D-STUP* (XBPT/XBPT-H) E24/E25	 B-SCLP/D-SCLP* (XBPC/XBPC-H) E42	 B-SCLC E36	 B-SVJB E55
	Carbide	 C-SWUB (WBPW) E21	 C-STUP/C-STUB (WBPW) E25	 C-SCLP (WBPC) E43	 C-SCLC E37	—
	Carbide with Oil hole	—	 E-STUP (WBPT-H) E26	—	 E-SCLC E37	—
Top Clamp Double Clamp	Steel	 CKB E12	 S-DWLN  E48	 S-DTFN  E34	 S-DCLN E45	—
	Carbide	—	 S-CTFP E31	—	—	—
	Steel with Oil Hole	 D-DWLN E47	—	 D-DTFN E34	 D-DCLN E45	—
Lever Lock	Steel	 S-PWLN  E48	 S-PTFN E33	 S-PCLN E46	—	—
	Anti-vibration	—	 B-PTFN E33	 B-PCLN E46	—	—
Pin Lock	Steel	—	 S-ETFN (BTFN) E35	 S-ECLN (BCLN) E47	—	—
Solid	Carbide	 BXBR E16	—	—	—	—
CBN	Carbide	 BSME  E18	 BNBX E20	 BNB E20	 SEXC  E19	 BNZ E35

\*mark:With coolant hole. Products in ( ) indicate the previous name of the series

# SEC- Boring Tools Series

## Guide for Selection by Application

Application		Through Boring	Copying			Back Turning		
Insert shape		Polygon  /Others	Square	55°Diamond	35°Diamond	55°Diamond	35°Diamond	
System/Shank type								
Screw Lock	Steel	S-SWUB(BBPW) E68 S-SWUP  E70	S-SSKP(BBPS) E71 S-SSKC E72	S-SDUC E49 S-SDQC E50	S-SVUC E58 S-SVUB  E57	S-SVQC E57 S-SVQB  E56	S-SDZC  E51	S-SVZC E60 S-SVZB  E59
	Anti-vibration	—	—	B-SDUC E49 B-SDQC E50	B-SVUB E58 B-SVQB E56	—	—	B-SVZB E59
	Carbide	C-SWUB (WBPW) E68	C-SSKP (WBPS) E71	C-SDUC E49	C-SVUB E58 C-SVQB E56	—	—	C-SVZB E59
	Carbide with Oil hole	—	—	—	—	—	—	—
Top Clamp Double Clamp	Steel	—	S-DSKN  E75	S-DDUN  E65 S-DDQN E65	—	—	—	—
	Carbide	—	S-CSKP E73	—	—	—	—	—
	Steel with Oil Hole	—	—	D-DDUN E65	—	—	—	—
Lever Lock	Steel	—	S-PSKN E75 S-PSYN E76	S-PDUN E66	—	—	S-PDZN E67	—
	Anti-vibration	—	—	—	—	—	—	—
Pin Lock	Steel	—	S-ESKN/S-ESYN (BSKN/BSYN) E76	S-EDUN (BDUN) E66	—	—	S-EDZN (BDZN) E67	—
Special Double Clamp	T-REX Tool Holders	—	—	S-DTR55C T-REX E67	—	—	—	—
CBN	Carbide	—	—	—	—	—	—	—

\*mark:With coolant hole. Products in ( ) indicate the previous name of the series

# Boring Tools Identification Table

## ■ Catalogue Classification System For SEC-Boring Holders (Round Shank) [ISO Standard]

(Example) **S 16 R - S T U P R 11 03 - 18**

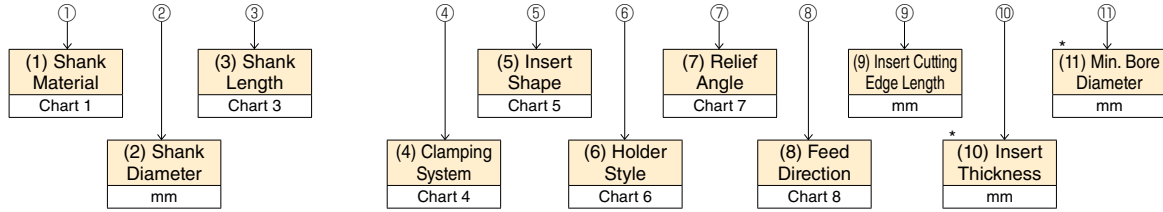

\* This code may only be included in some of the catalogue nos.

Chart 1

(1) Shank Material	
S	Steel
B	Steel with Anti-vibration mechanism
D	Steel with Anti-Vibration / Oil hole
C	Carbide
E	Carbide with Oil hole

Chart 3

(3) Shank Length					
Symbol	Length (mm)	Symbol	Length (mm)	Symbol	Length (mm)
F	80	M	150	T	300
G	90	N	160	U	350
H	100	P	170	V	400
J	110	Q	180	W	450
K	125	R	200		
L	140	S	250		

Chart 4

(4) Clamping System					
Symbol	System	Structure	Symbol	System	Structure
C	Top Clamp		M	Top Clamp + Pin Lock	
D	Double Clamp		P	Lever Lock (Insert is supported by 2 faces)	
E	Pin Lock (Insert is supported by 1 face)		S	Screw Lock	

Chart 8

(8) Feed Direction			
Symbol	Right Hand	Symbol	Left Hand
R		L	

Chart 5

(5) Insert Shape			
Symbol	Insert Shape	Symbol	Insert Shape
A	Parallelogram 85°	M	Diamond 86°
B	Parallelogram 82°	O	Octagonal
C	Diamond 80°	P	Pentagonal
D	Diamond 55°	R	Round
E	Diamond 75°	S	Square
F	Diamond 50°	T	Triangle
H	Hexagonal	V	Diamond 35°
K	Parallelogram 55°	W	Trigon
L	Rectangular		

Chart 6

(6) Holder Style ( — Indicates major cutting edge)					
Symbol	Shape	Offset	Symbol	Shape	Offset
A		Nil	N		Nil
B		Nil	Q		Yes
D		Nil	R		Yes
E		Nil	S		Yes
F		Yes	T		Yes
G		Yes	U		Yes
J		Yes	W		Yes
K		Yes	Y		Yes
L		Yes	Z		Yes

Chart 7

(7) Relief Angle	
Symbol	Relief Angle
A	3°
B	5°
C	7°
D	15°
E	20°
F	25°
G	30°
N	0°
P	11°
O	Special Angle

## ■ Catalogue Classification System For SEC-Boring Holders (Round Shank) [Sumitomo Electric Standard]

(Example) **WB P T - 2 12 R (H) (14)**

BB	Steel Shank Boring Bar
WB	Carbide Shank Boring Bar
XB	Steel Shank Boring Bar with Anti-Vibration Mechanism

P	Positive Insert
---	-----------------

Symbol	T	S	C
Insert Shape	3-cornered	4-cornered	80° Diamond

Oil Hole      Min. Bore Diameter

Symbol	R	L
Hand	Right	Left

Symbol	08	10	12	16	20	25
Shank Diameter (mm)	8	10	12	16	20	25

Symbol	5	6	2	0	3	4
Insert IC (mm)	3.97	4.76	6.35	7.94	9.525	12.70

# Selection Guide for Boring Tools

## Guide for Selection by Usage and Boring

Colored box: Manufacturable size (without oil hole), ●: Stock, ⊕: Stock with oil hole

Application	Tool Type	Shank Type Boring Depth (L / D)			Applicable Insert Type/Shape	Tooling	Min. Bore Diameter (mm)																					
		Steel	Carbide	Anti-vibration			* When different from header bore diameters, the correct values are written in the table.																					
						1	1.5	2	3	4	5	6	7	8	10	12	13	14	16	18	20	25	28	34	44	54	70	
Minimal Boring	<b>CKB</b> → E12	Up to 3			Coated Carbide SUMIDIA Special Insert		●	●	●	●	●																	
	<b>BXBR</b> → E16	Up to 5			Coated Carbide						●																	
	<b>DABB</b> → E17	Up to 2			Brazing SUMIDIA						●	●	●	●														
Stop Boring	<b>BSME</b> → E18	Up to 4			Brazing SUMIBORON																							
	<b>SEXC</b> → E19	Up to 3			SUMIBORON Special Insert																							
	<b>BNBX</b> → E20	Up to 5			Brazing SUMIBORON																							
	<b>BNB</b> → E20	Up to 4			SUMIBORON Special Insert														●	●	●	●						
	<b>S-SWUB</b> [BBPW] → E21	Up to 3											●	●	●													
	<b>C-SWUB</b> [WBPW] → E21	Up to 8											●															
	<b>S-SWUP</b> → E23	Up to 3																										
	<b>S-STUP/S-STUB</b> [BBPT] → E24	Up to 3														●	●	●	●	●	●	●	●	●	●	●	●	●
	<b>B-STUP/D-STUP</b> [XBPT/XBPT-H] → E24, E25			Up to 6												●	●	●	●	●	●	●	●	●	●	●	●	●
	<b>C-STUP(B)/E-STUP</b> [WBPT/WBPT-H] → E25, E26	Up to 8				Triangular Type 5°Positive (with hole) 11°Positive (with hole)										●	●	●	●	●	●	●	●	●	●	●	●	●
	<b>S-CTFP</b> → E31	Up to 3				Triangle 11°Positive (without hole)																						●
	<b>S-PTFN</b> → E33	Up to 3																										●
	<b>B-PTFN</b> → E33			Up to 6																								●
	<b>S-DTFN</b> → E34	Up to 3																										●
	<b>D-DTFN</b> → E34			Up to 6																								●
<b>S-ETFN</b> [BTFN] → E35	Up to 3				Triangular Type Negative (with hole)																						●	
Bottom Facing	<b>BNZ</b> → E35	Up to 5			SUMIBORON Special Insert										●	●	●	●	●	●	●	●	●	●	●	●	●	
	<b>S-SCLC</b> → E36	Up to 3														●	●	●	●	●	●	●	●	●	●	●	●	
	<b>B-SCLC</b> → E36			Up to 6												●	●	●	●	●	●	●	●	●	●	●	●	
	<b>C-SCLC</b> → E37	Up to 8														●	●	●	●	●	●	●	●	●	●	●	●	
	<b>E-SCLC</b> → E37	Up to 8 With oil hole				80°Diamond 7°Positive (with hole)										●	●	●	●	●	●	●	●	●	●	●	●	●

Products in [ ] indicate the previous name of the series

# Selection Guide for Boring Tools

Colored box: Manufacturable size (without oil hole), ●: Stock, ⊕: Stock with oil hole

Application	Tool Type	Shank Type Boring Depth (L / D)			Applicable Insert Type/Shape	Tooling	Min. Bore Diameter (mm)																												
		Steel	Carbide	Anti-vibration			* When different from header bore diameters, the correct values are written in the table.																												
							1	1.5	2	3	4	5	6	7	8	10	12	13	14	16	18	20	22	25	28	34	44	54	70						
Bottom Facing	<b>S-SCLP</b> [BBPC] → E42	Up to 3			80°Diamond 11°Positive(with hole)												●		●	●	●	●	●	●											
	<b>B-SCLP / D-SCLP</b> [XBPC/XBPC-H] → E42			Up to 6																	⊕	⊕	⊕												
	<b>C-SCLP</b> [WBPC] → E43		Up to 8																●		●	●	●												
	<b>S-DCLN</b> → E45	Up to 3			80°Diamond 11°Positive(with hole)	DCLN Type 																					●	40	50	63					
	<b>D-DCLN</b> → E45			Up to 6																							⊕	40	50						
	<b>S-PCLN</b> → E46	Up to 3						PCLN/BCLN Type 																					32			●	●		
	<b>B-PCLN</b> → E46			Up to 6																											●	●			
	<b>S-ECLN</b> [BCLN] → E47	Up to 3																											●	●	●	●			
	<b>D-DWLN</b> → E47			Up to 6	80°Diamond Negative(with hole)																							⊕	32	40	50				
	<b>S-DWLN</b> → E48	Up to 3																											32	40	50	63			
	<b>S-PWLN</b> → E48	Up to 3																														40	50		
	<b>S-DWLN</b> → E48	Up to 3						Polygon Negative(with hole)																											

Application	Tool Type	Shank Type Boring Depth (L / D)			Applicable Insert Type/Shape	Tooling	Min. Bore Diameter (mm)																													
		Steel	Carbide	Anti-vibration			* When different from header bore diameters, the correct values are written in the table.																													
							6	8	10	12	13	14	16	18	20	22	25	28	32	34	35	40	44	50	54	63	70									
Copying	<b>S-SDUC</b> → E49, E50	Up to 3			55°Diamond 7°Positive(with hole)	SDUC Type 						●		●		●	●	●	●	●																
	<b>B-SDUC</b> → E49, E50			Up to 6									●		●		●	●	●	●	●															
	<b>C-SDUC</b> → E49		Up to 8										●		●		●	●	●	●	●															
	<b>S-SDZC</b> → E51	Up to 3											●		●		●	●	●	●																
	<b>S-SVJB</b> → E55	Up to 3																			●	30														
	<b>B-SVJB</b> → E55			Up to 6																	●	30														
	<b>S-SVJC</b> → E55	Up to 3			35°Diamond 5°Positive(with hole) 7°Positive(with hole)									●		●		●	●	●	●															
	<b>S-SVQC</b> → E57, E58	Up to 3																																		
	<b>S-SVQB</b> → E56, E57	Up to 3																						●	●	●										
	<b>B-SVQB</b> → E56, E57			Up to 6																				●	●	●										
	<b>C-SVQB</b> → E56, E58	Up to 8																																		
	<b>S-SVZB</b> → E59	Up to 3																																		
	<b>S-SVZC</b> → E60	Up to 3																																		
	<b>B-SVZB</b> → E59			Up to 6																																
	<b>C-SVZB</b> → E59	Up to 8																																		

Products in [ ] indicate the previous name of the series

# Selection Guide for Boring Tools

Colored box: Manufacturable size (without oil hole), ●: Stock, ⊕: Stock with oil hole

Application	Tool Type	Shank Type Boring Depth (L / D)			Applicable Insert Type/Shape	Tooling	Min. Bore Diameter (mm)																				
		Steel	Carbide	Anti-vibration			6	8	10	12	13	14	16	18	20	22	25	28	32	34	35	40	44	50	54	63	70
Copying	<b>S-DDQN</b> → E65	Up to 3																			●						
	<b>S-DDUN</b> → E65	Up to 3																				●					
	<b>D-DDUN</b> → E65			Up to 6																		⊕	⊕				
	<b>S-PDUN</b> → E66	Up to 3																					●				
	<b>S-EDUN</b> [BDUN] → E66	Up to 3																					●				
	<b>S-PDZN</b> → E67	Up to 3																						●			
	<b>S-EDZN</b> [BDZN] → E67	Up to 3																						●			
	<b>S-DTR55C</b> → E67	Up to 3																						●	●		
Through Boring	<b>S-SWUB</b> [BBPW] → E68	Up to 3					●	●	●																		
	<b>C-SWUB</b> [WBPW] → E68		Up to 8																								
	<b>S-SWUP</b> → E70	Up to 3										●	●	●													
	<b>S-SSKP</b> [BBPS] → E71	Up to 3										●	●	●	●												
	<b>C-SSKP</b> [WBPS] → E71		Up to 8																								
	<b>S-SSKC</b> → E72	Up to 3																						●			
	<b>S-CSKP</b> → E73	Up to 3																									
	<b>S-DSKN</b> → E75	Up to 3																									
	<b>S-PSKN</b> → E75	Up to 3																						●			
	<b>S-PSYN</b> → E76	Up to 3																						●			
	<b>S-ESKN</b> [BSKN] → E76	Up to 3																						●			
	<b>S-ESYN</b> [BSYN] → E76	Up to 3																							●		

Products in [ ] indicate the previous name of the series

# SEC- Boring Tools Series

Full Support for Boring in Turning Applications



## General Feature

Following our SEC-Small Hole Boring Bars, which have been popular since their industry-leading launch in 1976, and steel/carbide shank holders with high rigidity heads, **SumiTurn X-Bar** with an anti-vibration mechanism has been added to this series. The SEC-Boring Tools Series provides further optimization of insert grades and chipbreakers.

## Characteristics

- Wide series selection for various boring operations.  
Stop boring / Bottom facing / Through boring / Copying
- Minimum bore diameters of CKB type from  $\phi$  1 mm and C-SCLC type from  $\phi$  5 mm
- New anti-vibration boring bars, **SumiTurn X-Bar**.
- **Short carbide shank** types C16M-STUP and C20M-STUP, for use on turret lathes.
- Wide selection of grades and chipbreakers available for various processes and work materials.

## Steel Shank Type with Anti-Vibration Mechanism



- High anti-vibration capabilities for effective rough boring of deep holes.
- Achieving low cost boring of large diameters and deep holes,  $\phi$ 32 mm shank is available.
- Excellent chip control with double chip pockets.
- Bars with internal coolant hole are also available.
- Negative insert holders (shank diameter  $\phi$  25 to  $\phi$  40 mm) are now stocked.

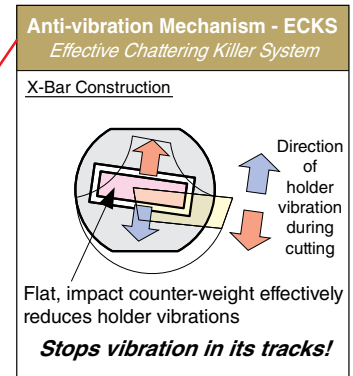
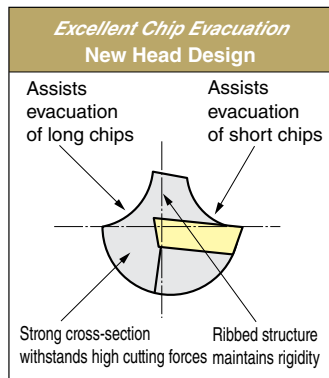

## Steel / Carbide Shank Applications

Steel Shank	Steel Shank with Anti-vibration Mechanism	Carbide Shank	Carbide Shank with Oil Hole
<b>High rigidity head design for low cost deep hole boring!</b>		<b>New short shank type for ease and economy.</b>	<b>Internal coolant supply for longer tool life!</b>

## Shank Material Selection



Application		Type	Steel Shank	Steel Shank with Anti-Vibration Mechanism	Carbide Shank
General Steel	Shallow hole (L/D < 3)		⊙ (More economical)	○ (High speed cutting)	
	Deep hole (L/D > 3)			⊙ (More economical)	⊙
High efficiency boring by wiper insert				○	⊙
Hardened Steel				—	⊙
High precision boring					⊙

## ⚠ Precautions for Clamping Position on Steel Shank with Anti-Vibration Mechanism

Clamping a shank on the portion labeled with **SUMITOMO ELECTRIC** may affect usage. (Due to built-in anti-vibration mechanism) Thus, minimum tool overhang should be 3.5D (3.5x shank dia).

⊙1st Recommendation ○2nd Recommendation



# SEC- Boring Tools Series

## Application Range by Shank Type

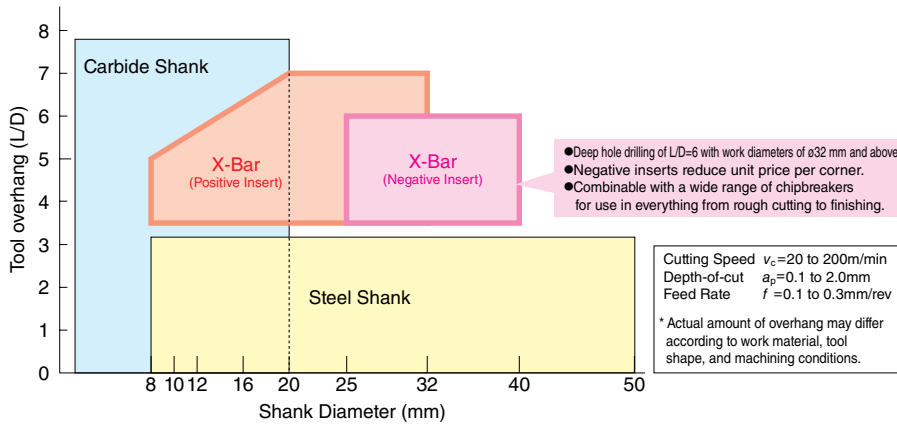

## Wear Comparison by Coolant Supply Method

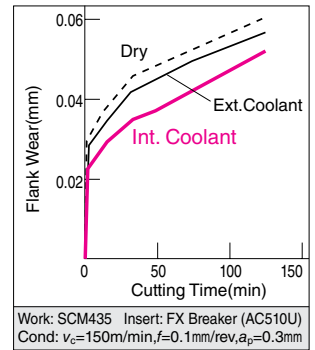

## Grade Recommendations

Tool Material	Application Range			Work Material							
	High Precision	Finish-Light Cut	Medium Cut	P General Steel	M Stainless Steel	K Cast Iron	S Heat Resistant Alloys	H Hardened Steel	N Non-Ferrous Metal	PI P/M	
Coated (Carbide)	CVD	AC810P			◎	○	○				
		AC820P			◎	○	○				
		AC830P			◎	○	○				
		AC6030M			○	◎					
		AC405K					◎				
		AC415K					◎				
		AC420K					◎				
	PVD	ACZ150			◎	◎				○	
		AC510U			◎	◎	○	◎			○
		AC520U			◎	◎	○	◎			○
		AC530U			◎	◎	○	○			○
		AC6040M				◎					
	Cermet Coated Cermet	T1000A			◎	○	◎			○	○
T1500A/T1500Z			◎	○	○			○	○		
T3000Z			◎	○				○	○		
Uncoated Carbide	G10E					◎			○		
CBN SUMIBORON	BN1000							◎			
	BN2000							◎			
	BNC2010							◎			
	BNC2020							◎			
	BN7000					◎	○			○	
PCD SUMIDIA	DA1000								◎		
	DA150								◎		

◎1st Recommendation ○2nd Recommendation

## Chipbreaker Recommendations

### ● M-Class Finish-Light Cut

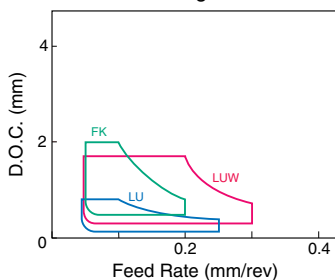

### ● M-Class Light-Medium Cut

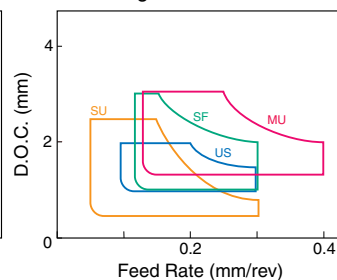

### ● G-Class Ground Type

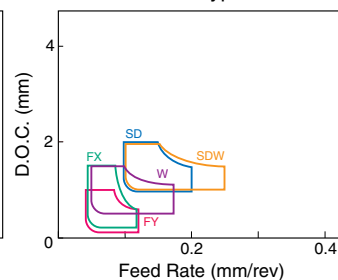

### ● G-Class Breaker

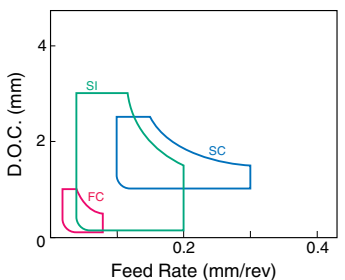

# Multi-functional Autolathe Tool Twin Head Holder



## Characteristics

- 1 holder that performs 2 operations is equivalent to mounting an additional tool on the machine.
- External turning possible with the aid of a drill sleeve.
- 2 holder configurations, internal+external and internal+internal, are standard stocked items.
- Height difference of the 2 cutting edges is below 40μm which is good for high precision machining.

## Advantage of twin-head holder

### Conventional tool

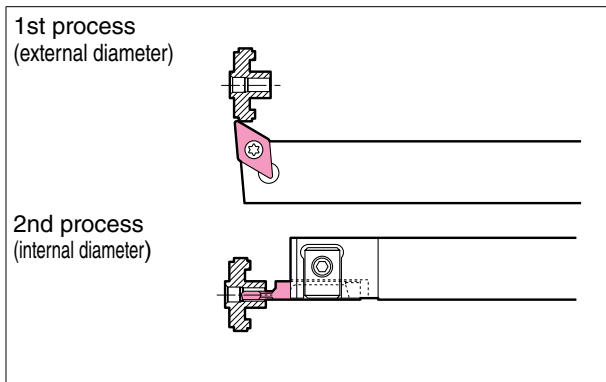

- 2 different operations requiring 2 separate tools.

### Twin head holder

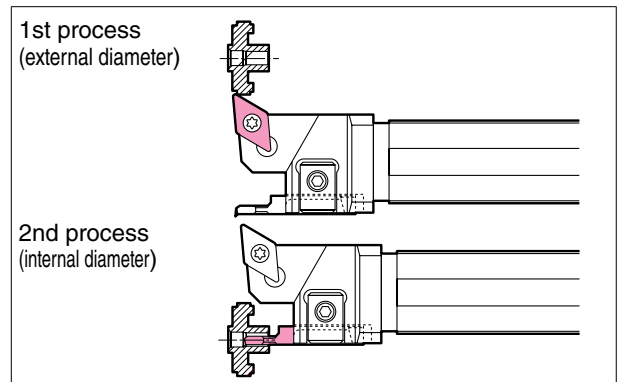

- A single tool performing 2 different operations.
- Cycle time can be reduced.

## Boring External Tool Holder

### CKBE type

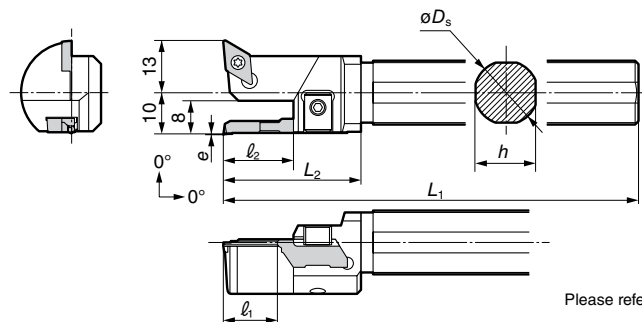
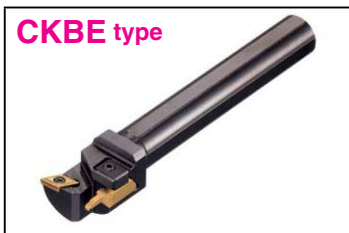

Please refer to page E13 for e.



### Holder (ID boring depth 6.0mm type)

Cat. No.	Stock	Dimensions (mm)						*Maximum workpiece diameter	ID Boring Insert	OD Turning Insert
		$\phi D_s$	$h$	$L_1$	$L_2$	$l_1$	$l_2$			
S1588X-CKBE-06	●	15.875	15	130	27	6	10	12.0	KBMX R0006-00 KBMX R0006-00T	DC□□070200
S16X-CKBE-06	●	16	15	130	27	6	10	12.0		
S1905X-CKBE-06	●	19.05	17	130	27	6	10	12.0		
S20X-CKBE-06	●	20	18	130	27	6	10	12.0		
S22X-CKBE-06	●	22	20	130	27	6	10	12.0		

\* When machining internal diameter

### Holder (ID boring depth 11.0mm type)

Cat. No.	Stock	Dimensions (mm)						*Maximum workpiece diameter	ID Boring Insert	OD Turning Insert
		$\phi D_s$	$h$	$L_1$	$L_2$	$l_1$	$l_2$			
S1588X-CKBE-11	●	15.875	15	130	32	11	15	12.0	KBMX R0011-00 KBMX R0011-00T	DC□□070200
S16X-CKBE-11	●	16	15	130	32	11	15	12.0		
S1905X-CKBE-11	●	19.05	17	130	32	11	15	12.0		
S20X-CKBE-11	●	20	18	130	32	11	15	12.0		
S22X-CKBE-11	●	22	20	130	32	11	15	12.0		

\* When machining internal diameter

ID Boring Insert E15

OD Turning Insert D20 to D23

# Multi-functional Autolathe Tool Twin Head Holder

Sumi Small

## Boring + Face Grooving

CKBB type

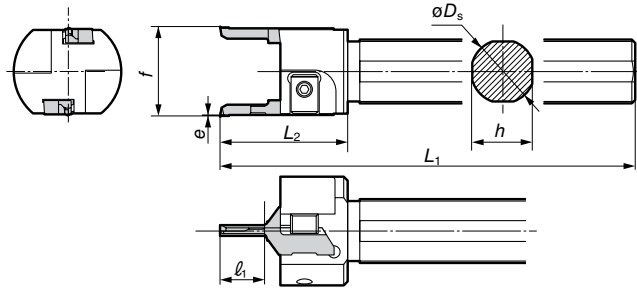

### Holder

Cat. No.	Stock	Dimensions (mm)						ID Boring Insert	OD Turning Insert
		$\phi D_s$	$h$	$L_1$	$L_2$	$f$	$\phi_1$		
S1588X-CKBB-F	●	15.875	15	130	32	22.0	11	KBMX R○○○○-○○ KBMX R○○○○-OOT	KBMF R○○○○-05
S16X-CKBB-F	●	16	15	130	32	22.0	11		
S1905X-CKBB-F	●	19.05	17	130	32	22.0	11		
S20X-CKBB-F	●	20	18	130	32	22.0	11		
S22X-CKBB-F	●	22	20	130	32	22.0	11		

\* Reference for  $L_1$ ,  $f$ , and  $\phi_1$  are taken with KBMXR0311-OO(T) mounted.

Insert selection E15

Insert Cat. Number: Using KBMXR (ID+ID) type

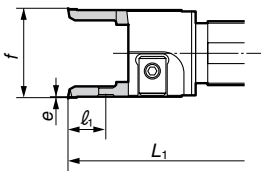

Cat. No.	$e$	$\phi_1$	$f$	$L_1$
KBMX R0103-○○(T)	0.2	3	21.8	122
KBMX R01506-○○(T)	0.25	6	21.9	125
KBMX R0206-○○(T)	0.25	6	21.9	125
KBMX R0311-○○(T)*	0.3	11	22.0	130
KBMX R0411-○○(T)	0.5	11	22.4	130
KBMX R0511-○○(T)	0.7	11	22.8	130
KBMX R0420-○○(T)	0.5	20	22.4	139
KBMX R0520-○○(T)	0.7	20	22.8	139

Insert Cat. Number: Using KBMFR (Face+Face) type

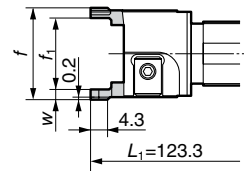

Cat. No.	$f$	$f_1$	$w$
KBMF R0615-05	21.8	18.8	1.5
KBMF R0620-05	21.8	17.8	2.0
KBMF R0630-05	21.8	15.8	3.0

### Spare Parts

For use with KBM □ R insert			For use with DC □□ insert		
		 (For Hexagonal Holes)		 (For Torx Holes)	
Clamp	Double Screw	Wrench	Screw	Wrench	Recommended Tightening Torque (N·m)
CKBW16	WB4-8	LH020	BFTX02506N	1.5	TRX08

### Special Holder Configurations



Int. diameter+Ext. diameter  
(Square shank holder)



Inner diameter + Center drill



Int. diameter + Int. diameter  
(Parallel boring holder)

Holder configurations for different workpieces or various machining requirements, such as guide holes, chamfering and external necking, can be custom-made.

Boring Bars

# SEC-MINI Boring Tool Holders CKB Type



## ■ Characteristics

- Minimum bore diameters from  $\phi 1\text{mm}$  to  $\phi 5\text{mm}$ .
- Maximum boring depth of  $20\text{mm}$  ( $\phi 4$ ,  $\phi 5\text{mm}$ ).
- Able to use with various auto-lathe machines.
- Unique design ensures **high indexing accuracy**.
- Simple insert change.

## ● High Indexing Accuracy

## ● Simple Insert Change

### ● CKB type Indexing Accuracy

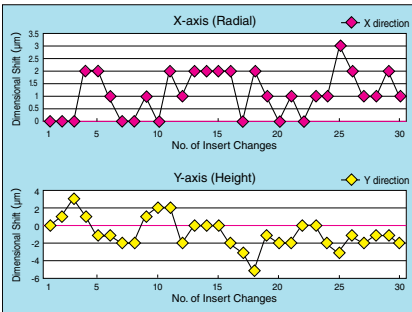

3 points of contact for high indexing

Insert change by just loosening a **SCREW**

Slanted clamp face results in stronger clamping

2 contact faces for high indexing accuracy

### ● Available Insert Grades

- ACZ150 ··· Stainless Steel, General Steel
- ACZ310 ··· Stainless Steel, General Steel
- DA2200 ··· Aluminum, Non-ferrous Metal

## ■ Round Shank Holder (Small Off-set) [S-CKB-S Type]

### ● Application range expansion with 2mm off-set bars

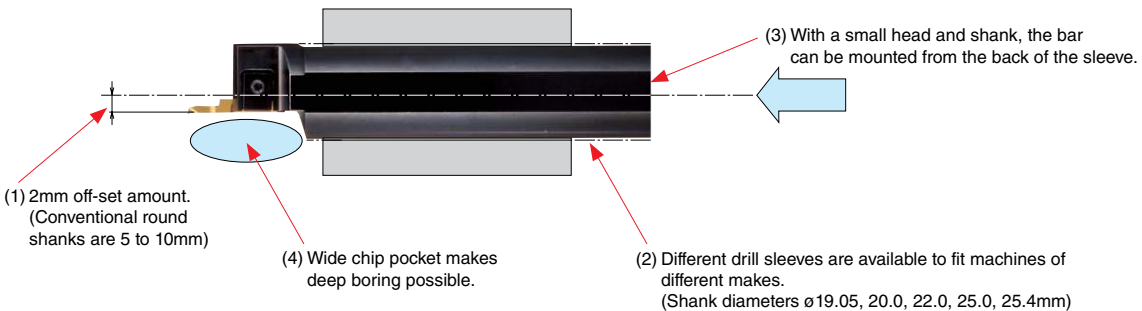



# SEC-MINI Boring Tool Holders CKB Type

## Mini Boring L-Styled

Sumi Small

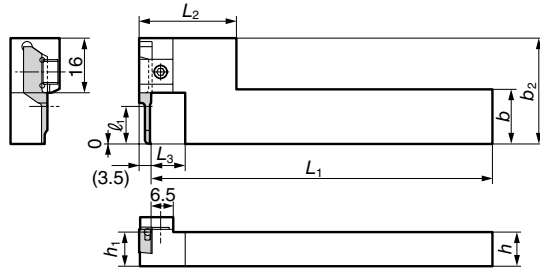

### Spare Parts

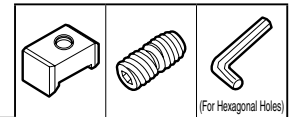

### Holder

Cat. No.	Stock	Dimensions (mm)							Applicable Insert	Clamp	Double Screw	Wrench
		$h=h_1$	$b$	$L_1$	$l_1$	$b_2$	$L_2$	$L_3$				
CKBS R1016-16-06	●	10	16	125	6	26	28.5	10	KBMX L0206-OOR	CKBW16	WB4-8	LH020
CKBS R1016-16-11	●	10	16	125	11	31	28.5	10	KBMX L03,04,0511-OOR			
CKBS R1216-16-06	●	12	16	150	6	26	28.5	10	KBMX L0206-OOR			
CKBS R1216-16-11	●	12	16	150	11	31	28.5	10	KBMX L03,04,0511-OOR			
CKBS R1216-16-20	●	12	16	150	20	40	28.5	10	KBMX L04,0520-OOR			
CKBS R1616-16-06	●	16	16	150	6	26	34.5	16	KBMX L0206-OOR			
CKBS R1616-16-11	●	16	16	150	11	31	34.5	16	KBMX L03,04,0511-OOR			
CKBS R1616-16-20	●	16	16	150	20	40	34.5	16	KBMX L04,0520-OOR			

### Insert

#### ● KBMX Type (For L-Styled Holder)

Cat. No.	ACZ310	Min. Bore Dia. $\phi D_m$	Dimensions (mm)						
			$F$	$e$	$r_\epsilon$	$l$	$l_1$		
KBMX L0206-05R	●	2.0	0.5	0.25	0.05	23.5	6		
KBMX L0206-20R	●				0.20				
KBMX L0311-05R	●	3.0	0.5	0.30	0.05	28.5	11		
KBMX L0311-20R	●				0.20				
KBMX L0411-05R	●	4.0	0.5	0.50	0.05	28.5	11		
KBMX L0411-20R	●				0.20				
KBMX L0420-05R	●				0.05			37.5	20
KBMX L0420-20R	●				0.20				
KBMX L0511-05R	●	5.0	0.5	0.50	0.05	28.5	11		
KBMX L0511-20R	●				0.20				
KBMX L0520-05R	●				0.05			37.5	20
KBMX L0520-20R	●				0.20				

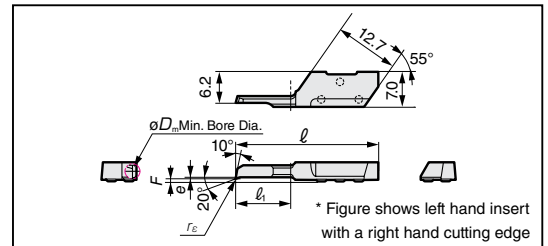

### Application Example (1)

Electronic Component (Free Cutting Stainless Steel)

**Holder** : CKBR1212-16  
**Insert** : **KBMXR 0420-05(ACZ310)**  
**Cutting Speed** :  $v_c=60\text{m/min}$   
**Feed Rate** :  $f=0.01\text{mm/rev}$   
**Depth of cut** :  $a_p=0.03\text{mm}$   
**Coolant** : Non-water soluble cutting oil

### Application Example (2)

Automotive Fuel Pump Component (SUS430)

**Holder** : CKBR1616-16  
**Insert** : **KBMXR 0206-05T(ACZ150)**  
**Cutting Speed** :  $v_c=80\text{m/min}$   
**Feed Rate** :  $f=0.03\text{mm/rev}$   
**Depth of cut** :  $a_p=0.05\text{mm}$   
**Coolant** : Non-water soluble cutting oil

Boring Bars

# SEC-MINI Boring Tool Holders CKB Type



Sumi Small

## Square Shank

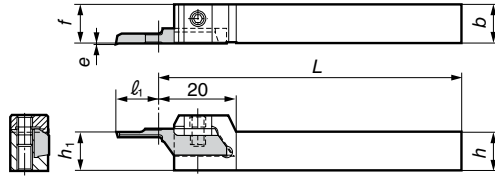

Please refer to facing page E15 for  $e$ ,  $l_1$  dimensions.

### Holder

Cat. No.	Stock	Dimensions (mm)					Clamp	Double Screw	Wrench
		$h$	$b$	$L$	$f$	$h_1$			
CKB R1010-16	●	10	10	100	10	10	CKBW16	WB4-8	LH020
CKB R1212-16	●	12	12	125	12	12			
CKB R1616-16	●	16	16	125	16	16			
CKB R2020-16	●	20	20	125	20	20			
CKB R2525-16	●	25	25	150	25	25			

### Spare Parts

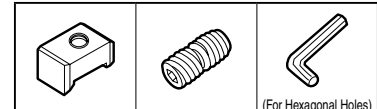

## Round Shank (Offset Small)

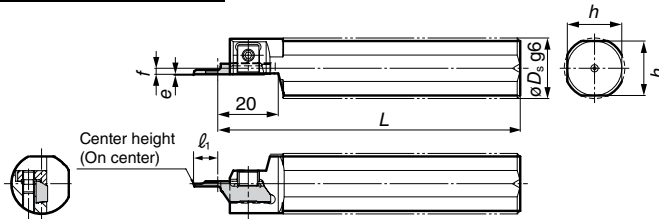

Please refer to facing page E15 for  $e$ ,  $l_1$  dimensions.

### Holder

Cat. No.	Stock	Dimensions (mm)					Clamp	Double Screw	Wrench
		$\phi D_s$	$h$	$L$	$f$				
S1905H-CKB RS-16	●	19.05	17	100	2		CKBW16	WB4-8	LH020
S20H-CKB RS-16	●	20	18	100	2				
S22K-CKB RS-16	●	22	19	125	2				
S25K-CKB RS-16	●	25	23	125	2				
S254K-CKB RS-16	●	25.4	23	125	2				

### Spare Parts

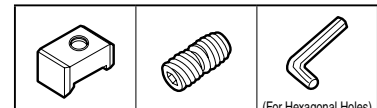

## Round Shank

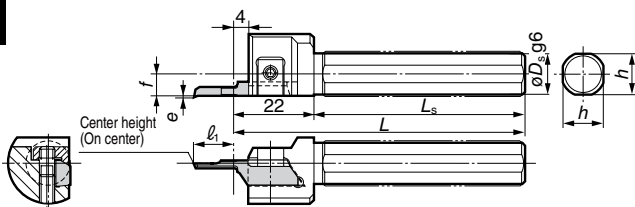

Please refer to facing page E15 for  $e$ ,  $l_1$  dimensions.

### Holder

Cat. No.	Stock	Dimensions (mm)					Clamp	Double Screw	Wrench
		$\phi D_s$	$h$	$L$	$L_s$	$f$			
S10F-CKB R-16	●	10	9	80	58	5	CKBW16	WB4-8	LH020
S12F-CKB R-16	●	12	11	80	58	6			
S16H-CKB R-16	●	16	15	100	78	8			
S19K-CKB R-16	●	19.05	17	125	103	8			
S20K-CKB R-16	●	20	18	125	103	10			

### Spare Parts

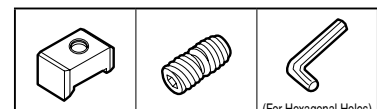

Sumi Small

# SEC-MINI Boring Tool Holders CKB Type

## ■ Insert

### ● KBMX Type, KBMX-T Type (Boring)

Cat. No.	ACZ310	Min. Bore Dia. $\phi D_m$	Dimensions (mm)					$l_1$
			F	e	$r_\epsilon$	$l$		
KBMX R0103-05	●	1.0	4.00	0.20	0.05	20.5	3	
KBMX R0103-20	●	1.0	4.00	0.20	0.20	20.5	3	
KBMX R01506-05	●	1.5	4.05	0.25	0.05	23.5	6	
KBMX R01506-20	●	1.5	4.05	0.25	0.20	23.5	6	
KBMX R0206-05	●	2.0	4.05	0.25	0.05	23.5	6	
KBMX R0206-20	●	2.0	4.05	0.25	0.20	23.5	6	
KBMX R0311-05	●	3.0	4.10	0.30	0.05	28.5	11	
KBMX R0311-20	●	3.0	4.10	0.30	0.20	28.5	11	
KBMX R0411-05	●	4.0	4.30	0.50	0.05	28.5	11	
KBMX R0411-20	●	4.0	4.30	0.50	0.20	28.5	11	
KBMX R0420-05	●	4.0	4.30	0.50	0.05	37.5	20	
KBMX R0420-20	●	4.0	4.30	0.50	0.20	37.5	20	
KBMX R0511-05	●	5.0	4.50	0.70	0.05	28.5	11	
KBMX R0511-20	●	5.0	4.50	0.70	0.20	28.5	11	
KBMX R0520-05	●	5.0	4.50	0.70	0.05	37.5	20	
KBMX R0520-20	●	5.0	4.50	0.70	0.20	37.5	20	

Cat. No.	ACZ160	Min. Bore Dia. $\phi D_m$	Dimensions (mm)					$l_1$
			F	e	$r_\epsilon$	$l$		
KBMX R0103-05T	●	1.0	4.00	0.20	0.05	20.5	3	
KBMX R0103-20T	●	1.0	4.00	0.20	0.20	20.5	3	
KBMX R01506-05T	●	1.5	4.05	0.25	0.05	23.5	6	
KBMX R01506-20T	●	1.5	4.05	0.25	0.20	23.5	6	
KBMX R0206-05T	●	2.0	4.05	0.25	0.05	23.5	6	
KBMX R0206-20T	●	2.0	4.05	0.25	0.20	23.5	6	
KBMX R0311-05T	●	3.0	4.10	0.30	0.05	28.5	11	
KBMX R0311-20T	●	3.0	4.10	0.30	0.20	28.5	11	
KBMX R0411-05T	●	4.0	4.30	0.50	0.05	28.5	11	
KBMX R0411-20T	●	4.0	4.30	0.50	0.20	28.5	11	
KBMX R0511-05T	●	5.0	4.50	0.70	0.05	28.5	11	
KBMX R0511-20T	●	5.0	4.50	0.70	0.20	28.5	11	

### ● KBMZ Type (Back Boring)

Cat. No.	ACZ310	Min. Bore Dia. $\phi D_m$	Dimensions (mm)					$l_2$
			F	e	$r_\epsilon$	$l$	$l_1$	
KBMZ R0411-05	●	4.0	5.10	1.3	0.05	28.5	9	11
KBMZ R0411-20	●	4.0	5.10	1.3	0.20	28.5	9	11
KBMZ R0511-05	●	5.0	5.10	1.3	0.05	28.5	9	11
KBMZ R0511-20	●	5.0	5.10	1.3	0.20	28.5	9	11

### ● KBMG Type (Internal Grooving)

Cat. No.	ACZ310	Min. Bore Dia. $\phi D_m$	Dimensions (mm)					$l_1$
			F	e	w	$r_\epsilon$	$l$	
KBMG R0411-05	●	4.0	4.90	1.1	1.00	0.05	28.5	11
KBMG R0411-10	●	4.0	4.90	1.1	2.00	0.10	28.5	11
KBMG R0511-05	●	5.0	5.10	1.3	1.00	0.05	28.5	11
KBMG R0511-10	●	5.0	5.10	1.3	2.00	0.10	28.5	11

### ● KBMF Type (End Grooving)

Cat. No.	ACZ160	Min. Bore Dia. $\phi D_m$	Dimensions (mm)					Max. groove depth (mm)
			F	e	w	$r_\epsilon$	$l$	
KBMF R0615-05	●	6.0	4.0	0.2	1.5	0.05	21.8	4.0
KBMF R0620-05	●	6.0	4.0	0.2	2.0	0.05	21.8	4.0
KBMF R0630-05	●	6.0	4.0	0.2	3.0	0.05	21.8	4.0

### ● KBMX Type (SUMIDIA / Boring)

Cat. No.	DAE200	Min. Bore Dia. $\phi D_m$	Dimensions (mm)					$l_1$
			F	e	$r_\epsilon$	$l$		
KBMX R0311-10	●	3.0	4.1	0.3	0.1	28.5	11	
KBMX R0411-10	●	4.0	4.3	0.5	0.1	28.5	11	
KBMX R0511-10	●	5.0	4.5	0.7	0.1	28.5	11	

### KBMX Type, KBMX-T Type (Boring)

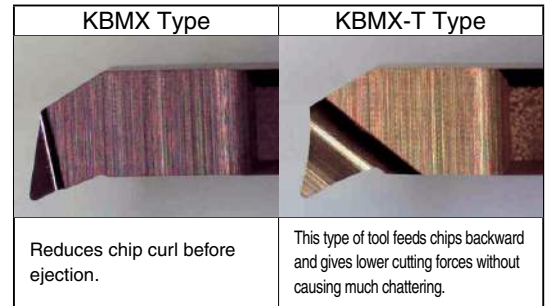
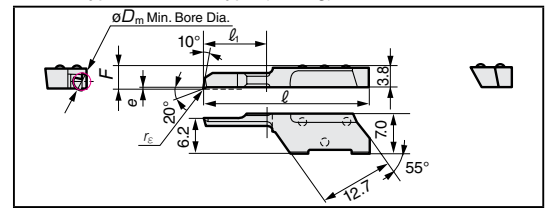

### KBMZ Type (Back Boring)

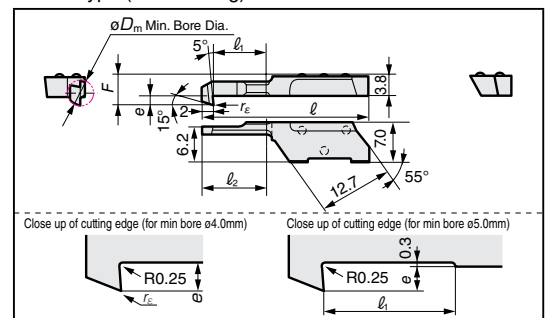

### KBMG Type (Internal Grooving)

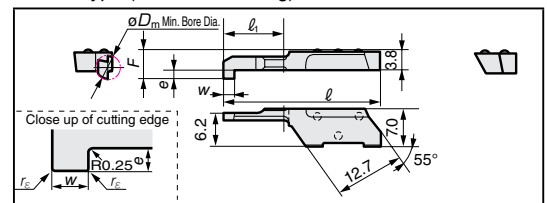

### KBMF Type (End Grooving)

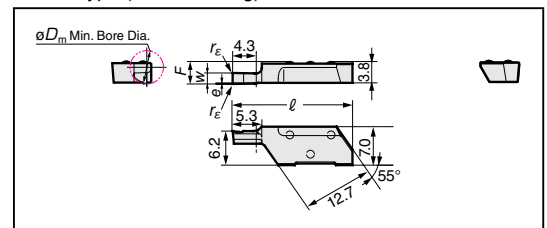

### KBMX Type (SUMIDIA / Boring)

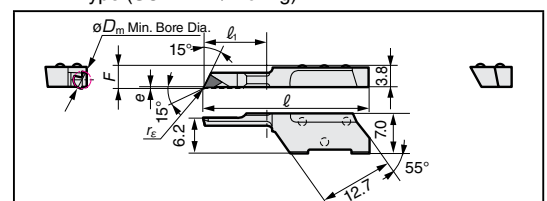

# Solid Carbide Bar BXBR Type



Sumi Small

## ■ Characteristics

- Economical, two-cornered insert.
- Maximum boring depth 5D (5 times the shank diameter)
- Usable at any desired overhang.
- Shank size = min. bore diameter for easy selection.  
(Available from  $\phi 2$  mm to  $\phi 5$  mm in 0.5 mm increments.)
- KBMX Type cutting edge used, no breaker versions also available in stock.

## Small Hole Finishing

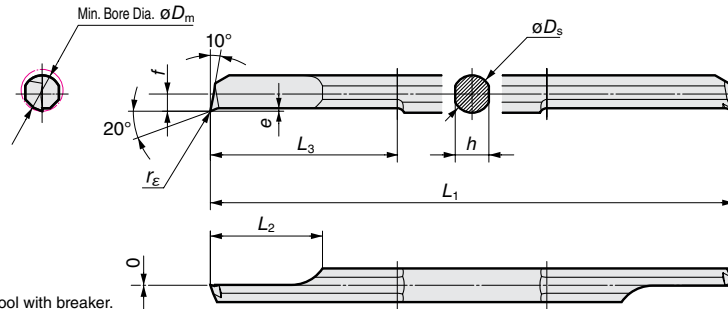
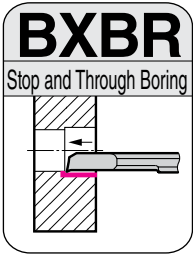

Figure shows tool with breaker.

## ■ Brazed Boring Bar

	Cat. No.	Stock		*Min. Bore Dia. $\phi D_m$	Dimensions (mm)								Applicable Sleeve
		ACZ150	AC530U		$\phi D_s$	$h$	$L_1$	$f$	$L_2$	$L_3$	$e$	$r_E$	
With Breaker	BXBR 02005R	●		2.0	2.0	1.8	50	0.80	6.0	10.0	0.20	0.05	HBX 2016
	BXBR 02020R	●		2.0	2.0	1.8	50	0.80	6.0	10.0	0.20	0.20	HBX 2016
	BXBR 02505R	●		2.5	2.5	2.2	50	1.05	7.5	12.5	0.20	0.05	HBX 2516
	BXBR 02520R	●		2.5	2.5	2.2	50	1.05	7.5	12.5	0.20	0.20	HBX 2516
	BXBR 03005R	●		3.0	3.0	2.7	50	1.30	9.0	15.0	0.25	0.05	HBX 3016
	BXBR 03020R	●		3.0	3.0	2.7	50	1.30	9.0	15.0	0.25	0.20	HBX 3016
	BXBR 03505R	●		3.5	3.5	3.1	60	1.55	10.5	17.5	0.25	0.05	HBX 3516
	BXBR 03520R	●		3.5	3.5	3.1	60	1.55	10.5	17.5	0.25	0.20	HBX 3516
	BXBR 04005R	●		4.0	4.0	3.6	60	1.80	12.0	20.0	0.35	0.05	HBX 4016
	BXBR 04020R	●		4.0	4.0	3.6	60	1.80	12.0	20.0	0.35	0.20	HBX 4016
	BXBR 04505R	●		4.5	4.5	4.1	70	2.05	13.5	22.5	0.35	0.05	HBX 4516
	BXBR 04520R	●		4.5	4.5	4.1	70	2.05	13.5	22.5	0.35	0.20	HBX 4516
	BXBR 05005R	●		5.0	5.0	4.5	70	2.30	15.0	25.0	0.40	0.05	HBX 5016
	BXBR 05020R	●		5.0	5.0	4.5	70	2.30	15.0	25.0	0.40	0.20	HBX 5016
	No Breaker	BXBR 02005R-NB	●		2.0	2.0	1.8	50	0.80	6.0	10.0	0.20	0.05
BXBR 02020R-NB		●		2.0	2.0	1.8	50	0.80	6.0	10.0	0.20	0.20	HBX 2016
BXBR 02505R-NB		●		2.5	2.5	2.2	50	1.05	7.5	12.5	0.20	0.05	HBX 2516
BXBR 02520R-NB		●		2.5	2.5	2.2	50	1.05	7.5	12.5	0.20	0.20	HBX 2516
BXBR 03005R-NB		●		3.0	3.0	2.7	50	1.30	9.0	15.0	0.25	0.05	HBX 3016
BXBR 03020R-NB		●		3.0	3.0	2.7	50	1.30	9.0	15.0	0.25	0.20	HBX 3016
BXBR 03505R-NB		●		3.5	3.5	3.1	60	1.55	10.5	17.5	0.25	0.05	HBX 3516
BXBR 03520R-NB		●		3.5	3.5	3.1	60	1.55	10.5	17.5	0.25	0.20	HBX 3516
BXBR 04005R-NB		●		4.0	4.0	3.6	60	1.80	12.0	20.0	0.35	0.05	HBX 4016
BXBR 04020R-NB		●		4.0	4.0	3.6	60	1.80	12.0	20.0	0.35	0.20	HBX 4016
BXBR 04505R-NB		●		4.5	4.5	4.1	70	2.05	13.5	22.5	0.35	0.05	HBX 4516
BXBR 04520R-NB		●		4.5	4.5	4.1	70	2.05	13.5	22.5	0.35	0.20	HBX 4516
BXBR 05005R-NB		●		5.0	5.0	4.5	70	2.30	15.0	25.0	0.40	0.05	HBX 5016
BXBR 05020R-NB		●		5.0	5.0	4.5	70	2.30	15.0	25.0	0.40	0.20	HBX 5016



\* Boring depth  $L_3$  or less.

## ■ Adaptor Sleeve

Cat. No.	Stock	Dimensions (mm)	Applicable Bar
		$\phi D_s$	
HBX 2016	●	2.0	BXBR 0200OR(-NB)
HBX 2516	●	2.5	BXBR 0250OR(-NB)
HBX 3016	●	3.0	BXBR 0300OR(-NB)
HBX 3516	●	3.5	BXBR 0350OR(-NB)
HBX 4016	●	4.0	BXBR 0400OR(-NB)
HBX 4516	●	4.5	BXBR 0450OR(-NB)
HBX 5016	●	5.0	BXBR 0500OR(-NB)

\* BXBR bars can be used with HBB type sleeves. Commercially available sleeves may also be used.  
\* Refer to page E20 for details on HBX type sleeves.

## ■ Spare Parts (For sleeve)

				
		(For Torx Holes)		
Screw	Recommended Tightening Torque (N·m)	Setting Screw	Wrench	Applicable Sleeve
BFTX0409N	3.4	BT06035T	TRD15	HBX0000

\* Adaptor sleeve is optional



# SUMIDIA Small Hole Boring Bars DABB Type

SUMIDIA

Sumi Small

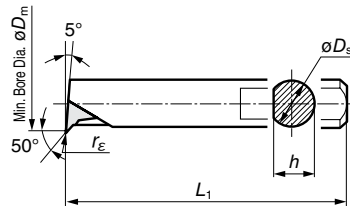
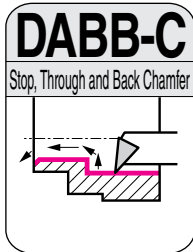

■ Brazed Bite

Cat. No.	Stock	Min. Bore Dia.	Dimensions (mm)				Applicable Sleeve
	DA2200	øD <sub>m</sub>	øD <sub>s</sub>	h	L <sub>1</sub>	r <sub>ε</sub>	
<b>DABB 025CR</b>	●	3.0	2.5	2.2	60	0.1	HBB 2516
<b>DABB 035CR</b>	●	4.0	3.5	3.2	60	0.1	HBB 3516
<b>DABB 045CR</b>	●	5.0	4.5	4.1	80	0.1	HBB 4516
<b>DABB 060CR</b>	●	7.0	6.0	5.2	80	0.1	HBB 616

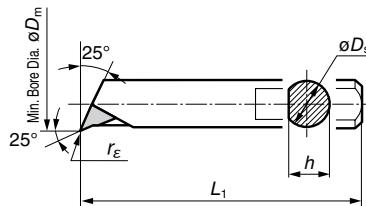
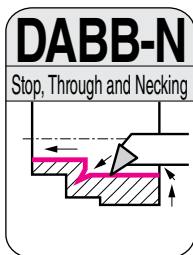

■ Brazed Bite

Cat. No.	Stock	Min. Bore Dia.	Dimensions (mm)				Applicable Sleeve
	DA2200	øD <sub>m</sub>	øD <sub>s</sub>	h	L <sub>1</sub>	r <sub>ε</sub>	
<b>DABB 025NR</b>	●	3.0	2.5	2.2	60	0.1	HBB 2516
<b>DABB 035NR</b>	●	4.0	3.5	3.2	60	0.1	HBB 3516
<b>DABB 045NR</b>	●	5.0	4.5	4.1	80	0.1	HBB 4516
<b>DABB 060NR</b>	●	7.0	6.0	5.2	80	0.1	HBB 616

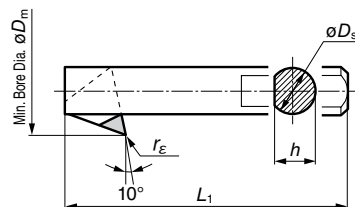
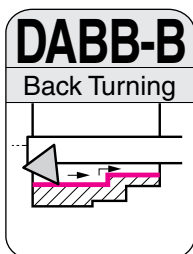

■ Brazed Bite

Cat. No.	Stock	Min. Bore Dia.	Dimensions (mm)				Applicable Sleeve
	DA2200	øD <sub>m</sub>	øD <sub>s</sub>	h	L <sub>1</sub>	r <sub>ε</sub>	
<b>DABB 045BR</b>	▲	7.0	4.5	4.0	80	0.1	HBB 4516
<b>DABB 060BR</b>	▲	9.0	6.0	5.5	80	0.1	HBB 616

Sumi Small

■ Spare Parts

■ Adaptor Sleeve

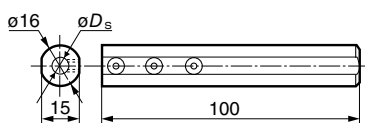

Cat. No.	Stock	øD <sub>s</sub> (mm)	Setting Screw		Wrench	
			Setting Screw	Wrench		
<b>HBB 2516</b>	●	2.5	BT 0404	TH 020	(For Hexagonal Holes)	
<b>HBB 3516</b>	●	3.5				
<b>HBB 4516</b>	●	4.5				
<b>HBB 616</b>	●	6.0				

# SUMIBORON Small Hole Boring Bars BSME Type

*New*



## ■ Characteristics

- Achieves the minimum bore diameter of  $\phi 2.5\text{mm}$  in the boring of hardened steel.
- Achieves high-precision cutting edge positioning thanks to the newly-developed clamp mechanism
- Expands the range of small hole boring to achieve more high-efficiency machining requiring no grinding.
- Brazed Type BSME Type  
Applicable to bore diameters ranging from  $\phi 2.5$  to  $5.0\text{mm}$
- Indexable Insert Type SEXC Type  
Applicable to bore diameters ranging from  $\phi 4.0$  to  $6.0\text{mm}$

## SUMIBORON

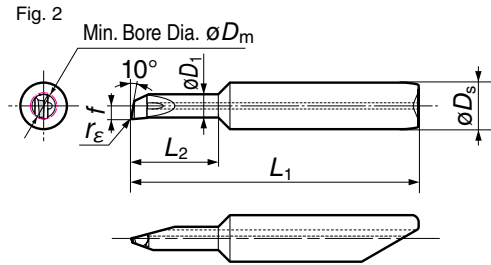
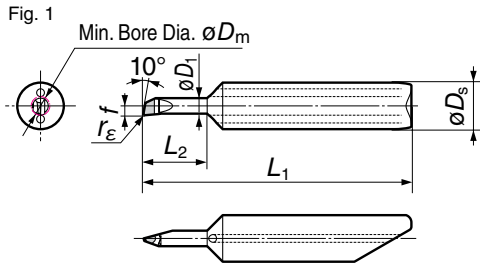
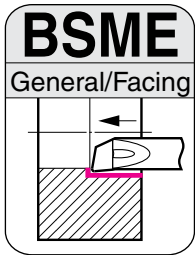

## ■ Brazed Boring Bar

Cat. No.	Stock		Min. Bore Dia.	Dimensions (mm)						Fig.	Applicable Sleeve
	BN2000			$\phi D_m$	$\phi D_s$	$\phi D_1$	$L_1$	$f$	$L_2$		
	R	L									
BSME R/L25020D2S6			2.5	6.0	2.0	32.0	1.20	5.3	0.2	1	HBSM6020
BSME R/L25020D3S6			2.5	6.0	2.0	34.5	1.20	7.8	0.2		
BSME R/L25020D4S6			2.5	6.0	2.0	37.0	1.20	10.3	0.2		
BSME R/L30020D2S6			3.0	6.0	2.5	32.8	1.45	6.3	0.2		
BSME R/L30020D3S6			3.0	6.0	2.5	35.8	1.45	9.3	0.2		
BSME R/L30020D4S6			3.0	6.0	2.5	38.8	1.45	12.3	0.2		
BSME R/L35020D2S6			3.5	6.0	3.0	33.5	1.70	7.3	0.2		
BSME R/L35020D3S6			3.5	6.0	3.0	37.0	1.70	10.8	0.2		
BSME R/L35020D4S6			3.5	6.0	3.0	40.5	1.70	14.3	0.2		
BSME R/L40020D2S6			4.0	6.0	3.5	33.9	1.95	8.3	0.2		
BSME R/L40020D3S6			4.0	6.0	3.5	37.9	1.95	12.3	0.2		
BSME R/L40020D4S6			4.0	6.0	3.5	41.9	1.95	16.3	0.2		
BSME R/L45020D2S6			4.5	6.0	4.0	35.0	2.20	9.3	0.2		
BSME R/L45020D3S6			4.5	6.0	4.0	39.5	2.20	13.8	0.2		
BSME R/L45020D4S6			4.5	6.0	4.0	44.0	2.20	18.3	0.2		
BSME R/L50020D2S6			5.0	6.0	4.5	35.8	2.45	10.3	0.2		
BSME R/L50020D3S6			5.0	6.0	4.5	40.8	2.45	15.3	0.2		
BSME R/L50020D4S6			5.0	6.0	4.5	45.8	2.45	20.3	0.2		

## ■ Adaptor Sleeve

Cat. No.	Stock	Dimensions (mm)		Setting Screw	Wrench
		$\phi D_s$	$L_1$		
HBSM6020		6.0	80	BT0506	TH025

## ■ Alignment Jig\*

Cat. No.	Stock
AFBSM60	

## ■ Newly Developed Clamp Mechanism

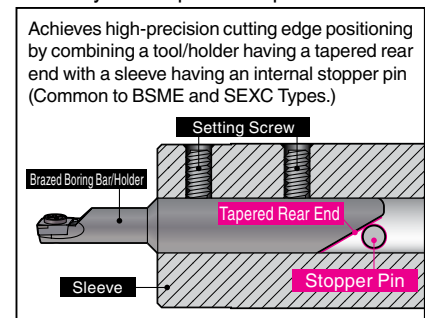

\* This jig is used for centering sleeves when setting them into holders.

*New*

# SUMIBORON Small Hole Boring Bars SEXC Type

## SUMIBORON

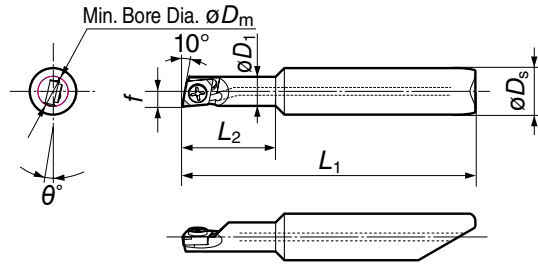
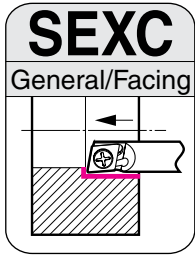

### ■ Spare Parts

Clamp Bolt	Wrench
MIB1.6-2	SDBSM
MIB1.6-2.5	
MIB1.6-3	
Recommended Tightening Torque (N·m)	0.2

### ■ Holder

Cat. No.	Stock		Min. Bore Dia. $\phi D_m$	Dimensions (mm)						Applicable Sleeve	Clamp Bolt	Recommended Tightening Torque (N·m)	Wrench
	R	L		$\phi D_s$	$\phi D_1$	$L_1$	$f$	$L_2$	$\theta^\circ$				
E06D2-SEXC R/L03-04P			4.0	6.0	3.75	33.75	1.95	8	-13	HBSM6020	MIB1.6-2	0.2	SDBSM
E06D3-SEXC R/L03-04P			4.0	6.0	3.75	37.75	1.95	12	-13				
E06D2-SEXC R/L03-05P			5.0	6.0	4.75	35.25	2.45	10	-12				
E06D3-SEXC R/L03-05P			5.0	6.0	4.75	40.25	2.45	15	-12				
E06D2-SEXC R/L03-06P			6.0	6.0	5.75	36.75	2.95	12	-11				
E06D3-SEXC R/L03-06P			6.0	6.0	5.75	42.75	2.95	18	-11				

### ■ Insert

Cat. No.	Stock		Dimensions (mm)
	BN2000	BN7000	Nose Radius $r_E$
2NU-ECXA 030X02LE			0.2
2NU-ECXA 030X02LF			0.2

LE: Honing, LF: Sharp Edge

### ■ Adaptor Sleeve

Cat. No.	Stock	Dimensions (mm)		Setting Screw	Wrench
		$\phi D_s$	$L_1$		
HBSM6020		6.0	80	BT0506	TH025

### ■ Alignment Jig

Cat. No.	Stock
AFBSM60	

### ■ Application Range

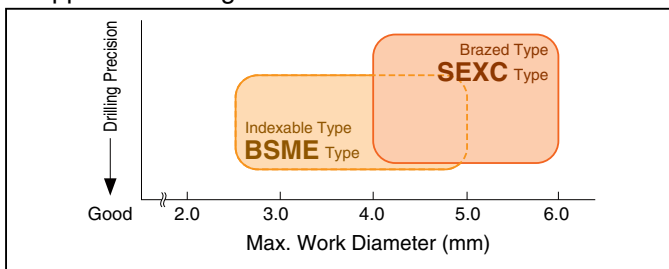

### ■ Recommended Cutting Conditions

Spindle Speed $n$	Above 2,000min <sup>-1</sup>	May cause chattering or chipping at the cutting edge in low-speed machining.
Depth-of-cut $a_p$	0.01 to 0.15mm	Excessive cutting depth causes deformation of the tool, which consequently leads to dimensional accuracy deterioration.
Feed Rate $f$	0.01 to 0.10mm/rev	—

### ■ Application Example

#### Hardened Alloy Steel Valve Component **BSME**

The BSME type provides stable machining and a tool life that is over 2 times longer than our competitors' CBN tools.

Tool Type	Output (pcs)
Indexable Type BSME	1,700 pcs
Comp. CBN Tool	600 pcs

Work Material : Hardened Alloy Steel Valve Component (Automotive Component)  
 Tool : BSME R50020D2S6 Grade : BN2000  
 Cutting Conditions :  $v_c=135\text{m/min}$  (7,500rpm)  $f=0.02\text{mm/rev}$   $a_p=0.10\text{mm}$  Dry

#### Bearing Steel Small Automotive Component **SEXC**

The SEXC type provides drastically reduced tool costs and a tool life that is 1.5 times longer than our competitors' brazed CBN tools.

Tool Type	Output (pcs)
Brazed Type SEXC	1,500 pcs
Comp. Brazed CBN Tool	1,000 pcs

Work Material : Bearing Steel Small Automotive Component (60HRC)  
 Holder : E06D2-SEXC R/L03-04P Insert : 2NU-ECXA 030X02LF (BN2000)  
 Cutting Conditions :  $v_c=50\text{m/min}$  (4,000rpm)  $f=0.02\text{mm/rev}$   $a_p=0.02\text{mm}$  Wet

Boring Bars

# SUMIBORON Small Hole Boring Bars BNBX/BNB Type

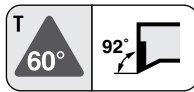

## SUMIBORON

SumiSmall

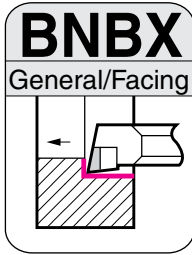

### ■ Brazen Boring Bar

Cat. No.	Stock				Min. Bore Dia.	Dimensions (mm)					Applicable Sleeve
	BN2000	BN250	BN7000	BN700	$\phi D_m$	$\phi D_s$	$h$	$L_1$	$r_\epsilon$		
<b>BNBX 020R</b>	●	▲	●	●	2.5	2.0	1.8	40	0.2	HBX 2016	
<b>BNBX 025R</b>	●	▲	●	●	3.0	2.5	2.2	40	0.2	HBX 2516	
<b>BNBX 030R</b>	●	▲	●	●	3.5	3.0	2.7	40	0.2	HBX 3016	
<b>BNBX 035R</b>	●	▲	●	●	4.0	3.5	3.2	40	0.2	HBX 3516	
<b>BNBX 040R</b>	●	▲	●	●	4.5	4.0	3.7	40	0.2	HBX 4016	
<b>BNBX 045R</b>	●	▲	●	●	5.0	4.5	4.2	40	0.2	HBX 4516	
<b>BNBX 050R</b>	●	▲	●	●	5.5	5.0	4.7	60	0.2	HBX 5016	
<b>BNBX 055R</b>	●	▲	●	●	6.0	5.5	5.2	60	0.2	HBX 5516	
<b>BNBX 060R</b>	●	▲	●	●	6.5	6.0	5.7	60	0.2	HBX 6016	
<b>BNBX 065R</b>	●	▲			7.0	6.5	6.2	60	0.2	HBB 6516	
<b>BNBX 070R</b>	●	▲			7.5	7.0	6.7	80	0.2	HBB 716	
<b>BNBX 075R</b>	●	▲			8.0	7.5	7.2	80	0.2	HBB 7516	
<b>BNBX 080R</b>	●	▲			8.5	8.0	7.7	80	0.2	HBB 816	

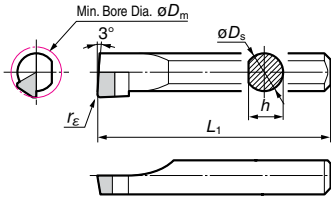

### ■ Adaptor Sleeve

Cat. No.	Stock	Dimensions (mm)	Applicable Bar
		$\phi D_s$	
<b>HBX 2016</b>	●	2.0	BNBX 020R
<b>HBX 2516</b>	●	2.5	BNBX 025R
<b>HBX 3016</b>	●	3.0	BNBX 030R
<b>HBX 3516</b>	●	3.5	BNBX 035R
<b>HBX 4016</b>	●	4.0	BNBX 040R
<b>HBX 4516</b>	●	4.5	BNBX 045R
<b>HBX 5016</b>	●	5.0	BNBX 050R
<b>HBX 5516</b>	●	5.5	BNBX 055R
<b>HBX 6016</b>	●	6.0	BNBX 060R
<b>HBB 6516</b>	●	6.5	BNBX 065R
<b>HBB 716</b>	●	7.0	BNBX 070R
<b>HBB 7516</b>	●	7.5	BNBX 075R
<b>HBB 816</b>	●	8.0	BNBX 080R

### ■ Spare Parts (For sleeve)

Screw	Recommended Tightening Torque (N·m)	Setting Screw	Wrench	Applicable Sleeve
BFTX0409N	3.4	BT06035T	TRD15	HBX○○○○○
—	—	BT0404	TH020	HBB○○○○○

\* BNBX bars can be use with HBB type sleeves, however, HBX type sleeves are recommended for bars below  $\phi$  6mm.

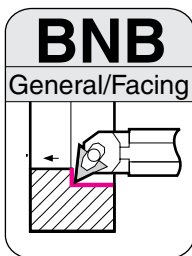

### ■ Holder

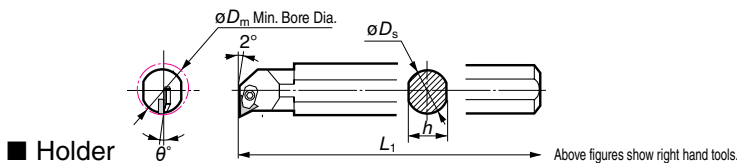

Cat. No.	Stock	Min. Bore Dia.	Dimensions (mm)				$\theta^\circ$
		$\phi D_m$	$\phi D_s$	$h$	$L_1$		
<b>BNB 508R</b>	●	10.0	8.0	7.0	140	-9	
<b>BNB 510R</b>	●	12.0	10.0	9.0	140	-8	
<b>BNB 512R</b>	●	14.0	12.0	11.0	160	-6	
<b>BNB 516R</b>	●	18.0	16.0	14.0	180	-5	
<b>BNB 520R</b>	●	22.0	20.0	18.0	180	-4	

### ■ Spare Parts

Clamp	Bolt	Nut	Wrench
BNBC	BH0306	BNBW-2	TH020
	FBUP3-A0-9	BNBW-4	
	BH0310	BNBW-7	

### ■ Insert ( SUMIBORON, SUMIDIA)

Cat. No.	Stock								Dimensions (mm) Nose Radius		
	SUMIBORON							SUMIDIA			
	BNX 10	BNX 20	BN2000	BN250	BN350	BN500	BN7000	BN700		DA150	DA1000
<b>TBGN 060102B</b>	●	●	●	▲	●	●	●	●	●	●	0.2
<b>TBGN 060104B</b>	●	●	●	▲	●	●	●	●	●	●	0.4
<b>TBGN 060108B</b>	●	●	●	▲	●	●	●	●	●	●	0.8
<b>TBGN 060102-BSTN*1</b>	—	●	—	—	—	—	—	—	—	—	0.2
<b>TBGN 060104-BSTN*1</b>	—	●	—	—	—	—	—	—	—	—	0.4
<b>TBGN 060108-BSTN*1</b>	—	●	—	—	—	—	—	—	—	—	0.8
<b>NF-TBGN 060102*2</b>	—	—	—	—	—	—	—	—	●	—	0.2
<b>NF-TBGN 060104*2</b>	—	—	—	—	—	—	—	—	●	—	0.4

\*1 TBGN ○○○○○○ -BSTN is only available in BNX20 grade and it has a smaller negative land angle (-15°) as compared to the B type.  
\*2 NF-TBGN is a single corner insert. (This is not a Full-Top insert)

# SEC-Boring Bars S-SWUB / C-SWUB Type

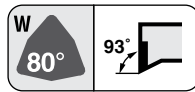

## Small Hole Finishing

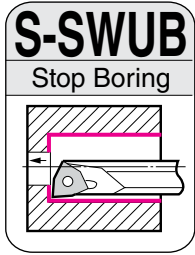

Steel

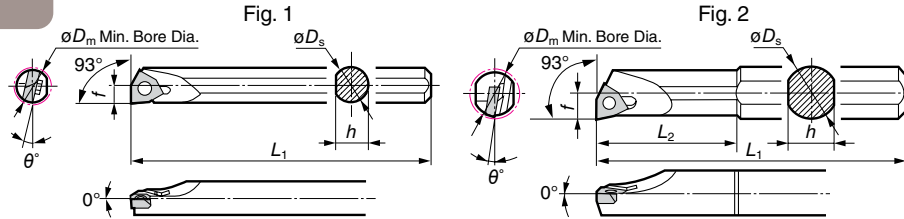

Sumi Small

### Spare Parts

Holder Right handed toolholders are applicable with left handed or neutral inserts.  
Left handed toolholders are applicable with right handed or neutral inserts.

Above figures show right hand tools.

Shank	Cat. No.	Conventional Cat. No.	Stock		Dimensions (mm)							Fig.	Applicable Insert	Screw	Recommended Tightening Torque (N·m)	Wrench	
			R	L	$\phi D_m$	$\phi D_s$	$h$	$L_1$	$f$	$L_2$	$\theta^\circ$						
Steel	S05H-SWUB R/L0601-06K	BBPW-508 RK/LK*	●	●	5.5	5	4.7	100	2.75	—	—	12	1	WB □□0601□□	BFTX0203N	0.5	TRX06
	S08H-SWUB R/L0601-06	BBPW-508 R/L	●	●	5.5	8	7.0	100	2.75	18	—	12	2				
	S08H-SWUB R/L0601-08	BBPW-508 R/L08*	●	●	8.0	8	7.0	100	4	30	—	10	2	WB □□0802□□	BFTX02205N	0.5	TRX06
	S08H-SWUB R/L0802-10	BBPW-608 R/L*	●	●	10.0	8	7.0	100	5	18	—	13	2				
	S10K-SWUB R/L0802-12	BBPW-610 R/L*	●	●	12.0	10	9.0	125	6	20	—	10	2				

S05H-SWUB R/L0601-06K needs adaptor sleeve (HBB516)

\* Product will be marked with ISO Cat. No.

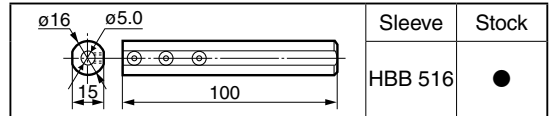

Adaptor sleeve is optional

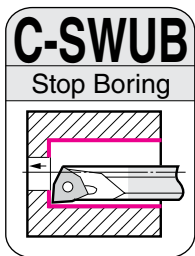

Carbide

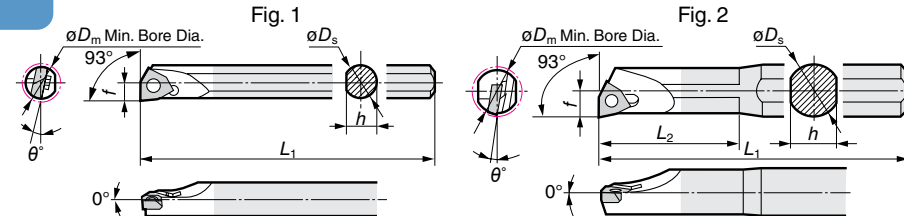

Sumi Small

### Spare Parts

Holder Right handed toolholders are applicable with left handed or neutral inserts.  
Left handed toolholders are applicable with right handed or neutral inserts.

Above figures show right hand tools.

Shank	Cat. No.	Conventional Cat. No.	Stock		Dimensions (mm)							Fig.	Applicable Insert	Screw	Recommended Tightening Torque (N·m)	Wrench	
			R	L	$\phi D_m$	$\phi D_s$	$h$	$L_1$	$f$	$L_2$	$\theta^\circ$						
Carbide	C05H-SWUB R/L0601-06K	WBPW-508 RK/LK*	●	●	5.5	5	4.7	100	2.75	—	—	12	1	WB □□0601□□	BFTX0203N	0.5	TRX06
	C08K-SWUB R/L0601-06	WBPW-508 R/L	●	●	5.5	8	7.0	125	2.75	30	—	12	2				

C05H-SWUB R/L0601-06K needs adaptor sleeve (HBB516)

\* Product will be marked with ISO Cat. No.

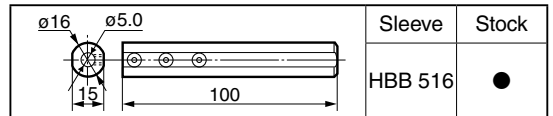

Adaptor sleeve is optional

Boring Bars

# SEC-Boring Bars SWUB Type



■ Insert ( Coated / Cermet / SUMIBORON / SUMIDIA)

● 5° Relief G-Class

WBGT FY		Stock				Dimensions (mm)		
		AC530U	T1000A	T1500A	T1200A	Inscribed circle	Thickness	Nose Radius
Cat. No.								
WBGT 0601003L-FY				●				0.03
060101R-FY				●				0.1
060101L-FY				●				0.1
060102R-FY		●	●	▲		3.97	1.59	0.2
060102L-FY		●	●	▲				0.2
060104R-FY		●	●	▲				0.4
060104L-FY		●	●	▲				0.4
WBGT 080201R-FY			●	●				0.1
080201L-FY			●	●				0.1
080202R-FY			●	●		4.76	2.38	0.2
080202L-FY			●	●				0.2
080204R-FY			●	●				0.4
080204L-FY			●	●				0.4

● 5° Relief E-Class

● SUMIBORON One-use Type

NU- WBEW		Stock			Dimensions (mm)		
		BNX20	BN7000	BN700	Inscribed circle	Thickness	Nose Radius
Cat. No.							
NU-WBEW 060102L-LF		—	●	●			0.2
060102L-LT		●	—	—	3.97	1.59	0.2
060104L-LT		●	—	—			0.4
NU-WBEW 080202L-LT		●	—	—	4.76	2.38	0.2
080204L-LT		●	—	—			0.4

\* LF: for sintered component and cast iron machining LT: for fine boring of hardened steel

● 5° Relief M-Class

● SUMIDIA NF Type

NF- WBMT		Stock				Dimensions (mm)		
		DA1000				Inscribed circle	Thickness	Nose Radius
Cat. No.								
NF-WBMT 060101L		●						0.1
060102L		●				3.97	1.59	0.2
060104L		●						0.4

● SUMIDIA

WBMT		Stock				Dimensions (mm)		
		DA2200				Inscribed circle	Thickness	Nose Radius
Cat. No.								
WBMT 060101L		▲						0.1
060102L		▲				3.97	1.59	0.2
060104L		▲						0.4

▲ mark : To be replaced by new item (Please confirm stock availability)

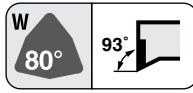

# SEC-Boring Bars S-SWUP Type

## Small Hole Finishing

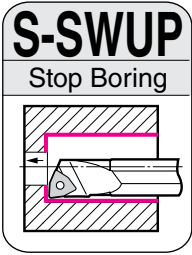

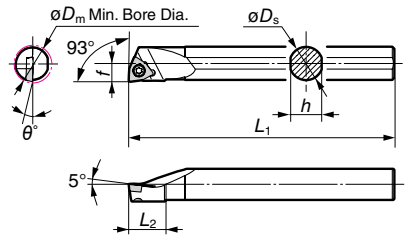

Steel

*New*



### ■ Spare Parts

		
		(For Torx Holes)
Applicable Insert	Screw	Wrench
	Recommended Tightening Torque (N·m)	
WP □ □ 1102 □ □	BFTX02505N	1.1
WP □ □ 1603 □ □	BFTX0407N	3.4
		TRX08
		TRX15

■ Holder Right handed toolholders are applicable with left handed or neutral inserts.  
Left handed toolholders are applicable with right handed or neutral inserts.

Above figures show right hand tools.

Shank	Cat. No.	Stock		Dimensions (mm)							Applicable Insert
		R	L	$\theta D_m$	$\theta D_s$	$h$	$L_1$	$f$	$L_2$	$\theta$	
Steel	<i>New</i> S12M-SWUP R/L1102-14	●		14	12	11	150	7	17	-6	WP □ □ 1102 □ □
	<i>New</i> S16Q-SWUP R/L1102-18	●		18	16	15	180	9	18	-3	
	<i>New</i> S16Q-SWUP R/L1603-18	●		18	16	15	180	9	18	-3	WP □ □ 1603 □ □
	<i>New</i> S20R-SWUP R/L1603-22	●		22	20	18	200	11	18	-2	

■ Insert (  Coated /  Cermet)

● 11° Relief M-Class

WPMT	LB	Cat. No.	Stock						Dimensions (mm)		
			AC820P	AC830P	AC6030M	AC6040M	T1500Z	T3000Z	T1500A	Inscribed circle	Thickness
<i>New</i>		WPMT 110204N-LB	●	●	●	●	●	●	6.35	2.38	0.4
<i>New</i>		WPMT 160308N-LB	●	●	●	●	●	●	9.525	3.18	0.8

Boring Bars

# SEC-Boring Bars S-STUP/S-STUB/B-STUP Type

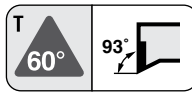

## Finish-Medium Cut

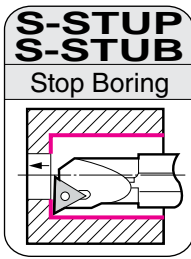

Steel

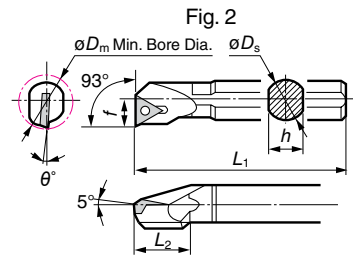
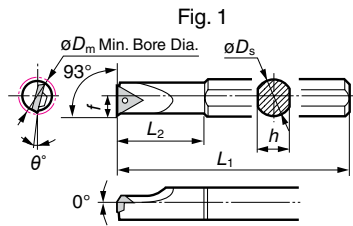

Sumi Small

### Spare Parts

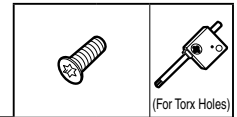

Holder Right handed toolholders are applicable with left handed or neutral inserts.  
Left handed toolholders are applicable with right handed or neutral inserts.

Above figures show right hand tools.

Shank	Cat. No.	Conventional Cat. No.	Stock		Dimensions (mm)							Fig.	Applicable Insert	Screw	Recommended Tightening Torque (N·m)	Wrench
			R	L	Min. Bore Dia. $\phi D_m$	$\phi D_s$	$h$	$L_1$	$f$	$L_2$	$\theta^\circ$					
Steel	S08H-STUP R/L0601-08	BBPT-508 R/L	●	●	8	8	7	100	4.0	30	-12	1	TP □□0601□□	BFTX0204A	0.5	TRX06
	S08H-STUP R/L0802-10	BBPT-608 R/L	●	●	10	8	7	100	5.0	13	-10	1	TP □□0802□□	BFTX02505N	1.1	TRX08
	S08H-STUP R/L0902-10	—	●	●	10	8	7	100	5.0	13	-10	2	TP □□0902□□	BFTX0306A	2.0	TRX10
	S10K-STUP R/L1103-12	BBPT-210 R/L	●	●	12	10	9	125	6.0	15	-8	2	TP □□1103□□	BFTX0307A	2.0	
	S12M-STUP R/L1103-14	BBPT-212 R/L14	●	●	14	12	11	150	7.0	17	-7			BFTX0306A	2.0	
	S12M-STUP R/L1103-16	BBPT-212 R/L	●	●	16	12	11	150	8.0	17	-6			BFTX0307A	2.0	
	S16R-STUP R/L1103-18	BBPT-216 R/L18	●	●	18	16	15	200	9.0	18	-4	2	TP □□1103□□	BFTX0307A	2.0	
	S16R-STUP R/L1103-20	BBPT-216 R/L	●	●	20	16	15	200	10.0	18	-2			BFTX0407A	2.0	
	S20S-STUP R/L1103-22	BBPT-220 R/L	●	●	22	20	18	250	11.0	18	-2			2	TP □□1603□□	BFTX0407A
	S25T-STUP R/L1103-28	BBPT-225 R/L	●	●	28	25	22	300	14.0	27	-2	BFTX0409N	3.4			TRX15
	S20S-STUP R/L1603-22	—	●	●	22	20	18	250	11.0	18	-3	BFTX0410A				
	S25T-STUP R/L1603-28	—	●	●	28	25	22	300	14.0	18	-1	2	TP □□1604□□	BFTX0407A	3.4	TRX15
	S20S-STUP R/L1604-22	—	●	●	22	20	18	250	12.5	18	-5			BFTX0409N		
	S20S-STUP R/L1604-25	BBPT-320 R/L	▲	▲	25	20	18	250	12.5	18	-3			BFTX0410A	3.4	
	S25T-STUP R/L1604-28	BBPT-325 R/L	●	●	28	25	22	300	14.0	18	-2	2				

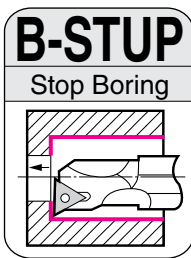

Anti-vibration

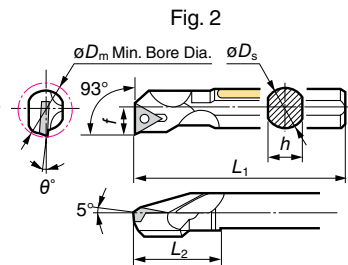
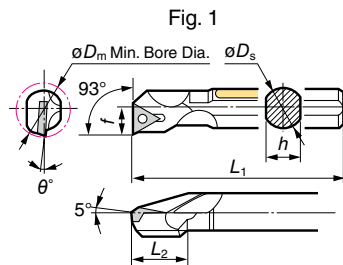

SumiTurn X-Bar

Sumi Small

### Spare Parts

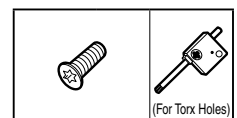

Holder Right handed toolholders are applicable with left handed or neutral inserts.  
Left handed toolholders are applicable with right handed or neutral inserts.

Above figures show right hand tools.

Shank	Cat. No.	Conventional Cat. No.	Stock		Dimensions (mm)							Fig.	Applicable Insert	Screw	Recommended Tightening Torque (N·m)	Wrench	
			R	L	Min. Bore Dia. $\phi D_m$	$\phi D_s$	$h$	$L_1$	$f$	$L_2$	$\theta^\circ$						
Anti-vibration	B08H-STUP R/L0802-10	XBPT-608 R/L	●	●	10	8	7	100	5.0	13	-10	1	TP □□0802□□	BFTX0204A	0.5	TRX06	
	B10K-STUP R/L1103-12	XBPT-210 R/L	●	●	12	10	9	125	6.0	15	-8	1	TP □□1103□□	BFTX0306A	2.0		
	B12M-STUP R/L1103-14	XBPT-212 R/L14	●	●	14	12	11	150	7.0	17	-7			BFTX0307A	2.0		
	B12M-STUP R/L1103-16	XBPT-212 R/L	●	●	16	12	11	150	8.0	17	-6			BFTX0306A	2.0		
	B16R-STUP R/L1103-18	XBPT-216 R/L18	●	●	18	16	15	200	9.0	18	-4	2	TP □□1103□□	BFTX0307A	2.0		
	B16R-STUP R/L1103-20	XBPT-216 R/L	●	●	20	16	15	200	10.0	18	-2			BFTX0407A	2.0		
	B20S-STUP R/L1103-22	XBPT-220 R/L	●	●	22	20	18	250	11.0	18	-2			1	TP □□1604□□	BFTX0410A	3.4
	B25T-STUP R/L1103-28	XBPT-225 R/L	●	●	28	25	22	300	14.0	18	-2	2					
	B32T-STUP R/L1103-40	XBPT-232 R/L	●	●	40	32	30	300	20.0	50	-2						
	B20S-STUP R/L1604-25	XBPT-320 R/L	●	●	25	20	18	250	12.5	18	-3	1	TP □□1604□□	BFTX0410A	3.4		
	B25T-STUP R/L1604-28	XBPT-325 R/L	●	●	28	25	22	300	14.0	18	-2			2			
	B32T-STUP R/L1604-40	XBPT-332 R/L	●	●	40	32	30	300	20.0	53	-2						



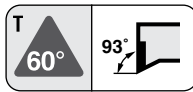

# SEC-Boring Bars D-STUP/C-STUP/C-STUB Type

## Finish-Medium Cut

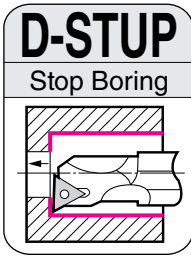

Anti-vibration with oil hole

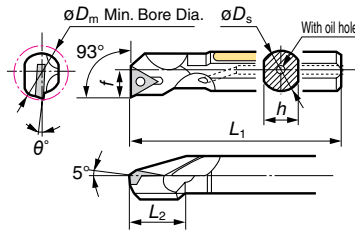

### Spare Parts

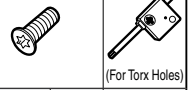

Holder Right handed toolholders are applicable with left handed or neutral inserts.  
Left handed toolholders are applicable with right handed or neutral inserts.

Above figures show right hand tools.

Shank	Cat. No.	Conventional Cat. No.	Stock		Dimensions (mm)							Applicable Insert	Screw	Recommended Tightening Torque (N·m)	Wrench
			R	L	$\theta D_m$	$\theta D_s$	$h$	$L_1$	$f$	$L_2$	$\theta^\circ$				
Anti-vibration with oil hole	<b>D12M-STUP R/L1103-14</b>	XBPT-212 R/L H14	●	●	14	12	11	150	7	17	-7	TP □□1103□□	BFTX0306A	2.0	TRX10
	<b>D16R-STUP R/L1103-18</b>	XBPT-216 R/L H18	●	●	18	16	15	200	9	18	-4		BFTX0307A	2.0	
	<b>D20S-STUP R/L1103-22</b>	XBPT-220 R/L H22	●	●	22	20	18	250	11	18	-2		BFTX0307A	2.0	

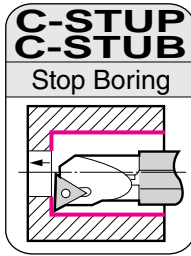

Carbide  
Carbide Long  
Carbide Short

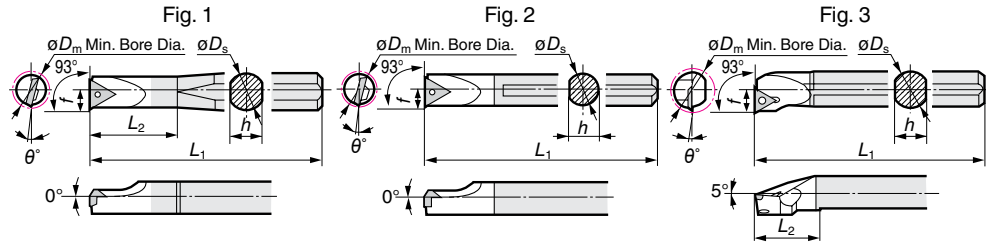

Above figures show right hand tools.

### Spare Parts



Holder Right handed toolholders are applicable with left handed or neutral inserts.  
Left handed toolholders are applicable with right handed or neutral inserts.

Shank	Cat. No.	Conventional Cat. No.	Stock		Dimensions (mm)							Fig.	Applicable Insert	Screw	Recommended Tightening Torque (N·m)	Wrench
			R	L	$\theta D_m$	$\theta D_s$	$h$	$L_1$	$f$	$L_2$	$\theta^\circ$					
Carbide Standard Length	<b>C08H-STUB R/L0601-08</b>	WBPT-508 RS/LS	●	●	8	8	7.0	100	4.0	50	-12	1	TB □□0601□□	BFTX0204A	0.5	TRX06
	<b>C08H-STUB R/L0601-08K</b>	WBPT-508 RSK/LSK *	●	●	8	6	5.7	100	4.0	—	-12	2		BFTX0204N	0.5	
	<b>C08H-STUP R/L0802-10</b>	WBPT-608 RS/LS	●	●	10	8	7.0	100	5.0	18	-10	3	TP □□0802□□	BFTX0204A	0.5	TRX06
	<b>C10K-STUP R/L1103-12</b>	WBPT-210 RS/LS	●	●	12	10	9.0	125	6.0	19	-8	3	TP □□1103□□	BFTX0306A	2.0	TRX10
	<b>C12M-STUP R/L1103-14</b>	WBPT-212 RS/LS14	●	●	14	12	11.0	150	7.0	25	-7			BFTX0307A	2.0	
	<b>C12M-STUP R/L1103-16</b>	WBPT-212 RS/LS	●	●	16	12	11.0	150	8.0	25	-6			BFTX0306A	2.0	
	<b>C16R-STUP R/L1103-18</b>	WBPT-216 RS/LS18	●	●	18	16	15.0	200	9.0	30	-4			BFTX0307A	2.0	
	<b>C16R-STUP R/L1103-20</b>	WBPT-216 RS/LS	●	●	20	16	15.0	200	10.0	30	-2			BFTX0306A	2.0	
	<b>C20S-STUP R/L1103-22</b>	WBPT-220 RS/LS	●	●	22	20	18.0	250	11.0	35	-2			BFTX0307A	2.0	
<b>C20S-STUP R/L1604-25</b>	WBPT-320 RS/LS	●	●	25	20	18.0	250	12.5	35	-3	3	TP □□1604□□	BFTX0410A	3.4	TRX15	
Carbide Long Type	<b>C08M-STUB R/L0601-08</b>	WBPT-508 R/L	●	●	8	8	7.0	150	4.0	50	-12	1	TB □□0601□□	BFTX0204A	0.5	TRX06
	<b>C08M-STUP R/L0802-10</b>	WBPT-608 R/L	●	●	10	8	7.0	150	5.0	18	-10	3	TP □□0802□□	BFTX0204A	0.5	TRX06
	<b>C10Q-STUP R/L1103-12</b>	WBPT-210 R/L	●	●	12	10	9.0	180	6.0	19	-8	3	TP □□1103□□	BFTX0306A	2.0	TRX10
	<b>C12R-STUP R/L1103-14</b>	WBPT-212 R/L14	●	●	14	12	11.0	200	7.0	25	-7			BFTX0307A	2.0	
	<b>C16S-STUP R/L1103-18</b>	WBPT-216 R/L18	●	●	18	16	15.0	250	9.0	30	-4			BFTX0306A	2.0	
	<b>C16S-STUP R/L1103-20</b>	WBPT-216 R/L	●	●	20	16	15.0	250	10.0	30	-2			BFTX0307A	2.0	
Carbide Short Type	<b>C16M-STUP R/L1103-18</b>	WBPT-216 RE/LE18	●	●	18	16	15.0	150	9.0	30	-4	3	TP □□1103□□	BFTX0306A	2.0	TRX10
	<b>C16M-STUP R/L1103-20</b>	WBPT-216 RE/LE	●	●	20	16	15.0	150	10.0	30	-2			BFTX0307A	2.0	
	<b>C20M-STUP R/L1103-22</b>	WBPT-220 RE/LE	●	●	22	20	18.0	150	11.0	35	-2			BFTX0307A	2.0	
	<b>C20M-STUP R/L1604-25</b>	WBPT-320 RE/LE	●	●	25	20	18.0	150	12.5	35	-3			3	TP □□1604□□	

C08H-STUB R/L0601-08K requires the sold separately sleeve HBB616.

The actual product marked with an asterisk (\*) is provided with ISO Cat. No.

Sleeve	Stock
HBB 616	●

Adaptor sleeve is optional

E Boring Bars

# SEC-Boring Bars E-STUP Type

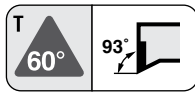

## Finish-Medium Cut

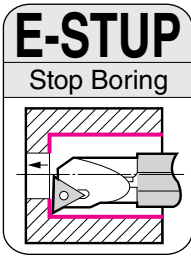

Carbide  
Oil Hole

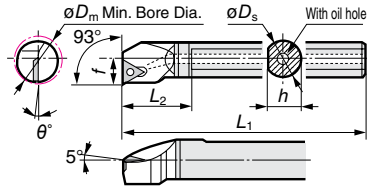

Sumi Small

■ Holder Right handed toolholders are applicable with left handed or neutral inserts.

### ■ Spare Parts

	(For Torx Holes)

Shank	Cat. No.	Conventional Cat. No.	Stock	Min. Bore Dia.	Dimensions (mm)						Applicable Insert	Screw	Recommended Tightening Torque (N·m)	Wrench
					R	$\theta D_m$	$\theta D_s$	h	$L_1$	f				
Carbide with oil hole	<b>E08H-STUP R0802-10</b>	WBPT-608 RH	●	10	8	7.5	100	5	18	-10	TP □□0802○○	BFTX0204A	0.5	TRX06
	<b>E10K-STUP R1103-12</b>	WBPT-210 RH	●	12	10	9.5	125	6	19	-8	TP □□1103○○	BFTX0306A	2.0	TRX10
	<b>E12M-STUP R1103-14</b>	WBPT-212 RH14	●	14	12	11.5	150	7	25	-7				
	<b>E12M-STUP R1103-16</b>	WBPT-212 RH	●	16	12	11.5	150	8	25	-6				
	<b>E16R-STUP R1103-18</b>	WBPT-216 RH18	●	18	16	15.5	200	9	30	-4				
	<b>E16R-STUP R1103-20</b>	WBPT-216 RH	●	20	16	15.5	200	10	30	-2				



# SEC-Boring Bars STUP/STUB Type

■ Insert ( Coated / Cermet / Carbide)

## ● 5°/11° Relief G-Class

TBGT TPGT FW		Stock					Dimensions (mm)		
		T1500Z	T2000Z	T1000A	T1500A	T1200A	Inscribed circle	Thickness	Nose Radius
Cat. No.									
TBGT 060102R-FW		●			●	▲	3.97	1.59	0.2
060102L-FW		●	▲		●	▲			0.2
060104R-FW		●			●	▲			0.4
060104L-FW		●	▲		●	▲			0.4
TPGT 080202R-FW		●		●	●	▲	4.76	2.38	0.2
080202L-FW		●	▲	●	●	▲			0.2
080204R-FW		●		●	●	▲			0.4
080204L-FW		●	▲	●	●	▲			0.4

## ● 5°/11° Relief G-Class

TBGT TPGT W		Stock									Dimensions (mm)			
		AC530U	T1500Z	T3000Z	T2000Z	T1000A	T1500A	T110A	T1200A	ST10P	G10E	Inscribed circle	Thickness	Nose Radius
Cat. No.														
TBGT 060102R-W		●	●		▲	●	●	▲	●	●	●	3.97	1.59	0.2
060102L-W		●	●		▲	●	●	▲	●	●	0.2			
060104R-W		●	●		▲	●	●	▲	●	●	0.4			
060104L-W		●	●		▲	●	●	▲	●	●	0.4			
TPGT 080202R-W		●	●		▲	●	●	▲	●	●	4.76	2.38	0.2	
080202L-W		●	●		▲	●	●	▲	●	●			0.2	
080204R-W		●	●		▲	●	●	▲	●	●			0.4	
080204L-W		●	●		▲	●	●	▲	●	●			0.4	

TBGT TPGT FX		Stock						Dimensions (mm)		
		AC510U	AC520U	AC530U	T1000A	T1500A	T1200A	Inscribed circle	Thickness	Nose Radius
Cat. No.										
TBGT 060102R-FX		●		●				3.97	1.59	0.2
060102L-FX		●		●						0.2
060104R-FX		●		●						0.4
060104L-FX		●		●						0.4
TPGT 080202R-FX		●	●	●				4.76	2.38	0.2
080202L-FX		●	●	●						0.2
080204R-FX		●	●	●						0.4
080204L-FX		●	●	●						0.4
TPGT 090204L-FX					●	●	▲	5.56	2.38	0.4
TPGT 110302R-FX										0.2
110302L-FX								6.35	3.18	0.2
110304R-FX										0.4
110304L-FX										0.4
110308R-FX										0.8
110308L-FX								0.8		

TBGW TPGW —		Stock						Dimensions (mm)		
		AC503U	AC510U	T1000A	T110A	T1500A	G10E	Inscribed circle	Thickness	Nose Radius
Cat. No.										
TBGW 060102								3.97	1.59	0.2
060104										0.4
TPGW 080202				●	●		▲	4.76	2.38	0.2
TPGW 110302		●								0.2
110304		●	●	●	●	▲	●	6.35	3.18	0.4
110308		●	●	●	●	▲	●			0.8
TPGW 160404			●				●	9.525	4.76	0.4

TBGT TPGT FY		Stock							Dimensions (mm)				
		AC520U	AC530U	ACZ150	T1500Z	T3000Z	T2000Z	T1000A	T1500A	T1200A	Inscribed circle	Thickness	Nose Radius
Cat. No.													
TBGT 060101R-FY			●								3.97	1.59	0.1
060101L-FY			●										0.1
060102R-FY			●					●	▲				0.2
060102L-FY			●					●	▲				0.2
060104R-FY			●					●	▲				0.4
060104L-FY			●					●	▲				0.4
TPGT 0802003R-FY		●	●								4.76	2.38	0.03
0802003L-FY		●	●										0.03
080201R-FY		●	●										0.1
080201L-FY		●	●										0.1
080202R-FY		●	●					●	▲				0.2
080202L-FY		●	●					●	▲				0.2
080204R-FY		●	●					●	▲				0.4
080204L-FY		●	●					●	▲				0.4
TPGT 1103003R-FY		●	●								6.35	3.18	0.03
1103003L-FY		●	●										0.03
110301R-FY		●	●										0.1
110301L-FY		●	●										0.1
110302R-FY		●	●					▲	●	▲			0.2
110302L-FY		●	●					▲	●	▲			0.2
110304R-FY		●	●					▲	●	▲			0.4
110304L-FY		●	●					▲	●	▲			0.4
110308R-FY		●	●					▲	●	▲			0.8
110308L-FY		●	●					▲	●	▲			0.8

TBGT TPGT AY		Stock										Dimensions (mm)		
		H1										Inscribed circle	Thickness	Nose Radius
Cat. No.														
TBGT 060101R-AY		●										3.97	1.59	0.1
060101L-AY		●									0.1			
060102R-AY		●									0.2			
060102L-AY		●									0.2			
060104R-AY		●									0.4			
060104L-AY		●									0.4			
TPGT 080201R-AY		●									4.76	2.38	0.1	
080201L-AY		●											0.1	
080202R-AY		●											0.2	
080202L-AY		●											0.2	
080204R-AY		●											0.4	
080204L-AY		●											0.4	
TPGT 110301R-AY		●									6.35	3.18	0.1	
110301L-AY		●											0.1	
110302R-AY		●											0.2	
110302L-AY		●											0.2	
110304R-AY		●											0.4	
110304L-AY		●											0.4	

## ● 11° Relief G-Class

TPGT SD		Stock								Dimensions (mm)		
		AC510U	AC530U	T1500Z	T3000Z	T2000Z	T1000A	T1500A	ST10P	G10E	Inscribed circle	Thickness
Cat. No.												
TPGT 110302R-SD										6.35	3.18	0.2
110302L-SD												0.2
110304R-SD												0.4
110304L-SD												0.4
110308R-SD												0.8
110308L-SD												0.8
TPGT 160402R-SD										9.525	4.76	0.2
160402L-SD												0.2
160404R-SD												0.4
160404L-SD												0.4
160408R-SD												0.8
160408L-SD												0.8

▲ mark : To be replaced by new item (Please confirm stock availability)

# SEC-Boring Bars STUP/STUB Type



■ Insert ( Coated / Cermet / Carbide)

## ● 11° Relief G-Class

TPGX SDW		Stock				Dimensions (mm)		
		T1500Z	T3000Z	T1500A		Inscribed circle	Thickness	Nose Radius
Cat. No.								
TPGX 110304R-SDW		●	●			6.35	3.18	0.4
110304L-SDW		●	●					0.4
110308R-SDW		●	●					0.8
110308L-SDW		●	●					0.8
TPGX 160404R-SDW		●	●	●		9.525	4.76	0.4
160404L-SDW		●	●	●				0.4
160408R-SDW		●	●	●				0.8
160408L-SDW		●	●	●				0.8

TPGT FC		Stock				Dimensions (mm)		
		AC520U	AC530U	T1000A	T1500A	Inscribed circle	Thickness	Nose Radius
Cat. No.								
TPGT 110302MN-FC		●	●	●	●	6.35	3.18	<0.2
110304MN-FC		●	●	●	●			<0.4

Values for nose radius prefixed with "<" mean minus tolerances.

## ● 11° Relief M-Class

TPMT FB		Stock					Dimensions (mm)		
		AC530U	T1500Z	T3000Z	T1000A	T1500A	Inscribed circle	Thickness	Nose Radius
Cat. No.									
TPMT 080202N-FB		●	●	●	●	●	4.76	2.38	0.2
080204N-FB		●	●	●	●	●			0.4
TPMT 090202N-FB		●	●	●	●	●	5.56	2.38	0.2
090204N-FB		●	●	●	●	●			0.4
TPMT 110302N-FB		●	●	●	●	●	6.35	3.18	0.2
110304N-FB		●	●	●	●	●			0.4
110308N-FB		●	●	●	●	●			0.8
TPMT 160304N-FB		●	●	●	●	●	9.525	3.18	0.4
160308N-FB		●	●	●	●	●			0.8
TPMT 160404N-FB		●	●	●	●	●	9.525	4.76	0.4
160408N-FB		●	●	●	●	●			0.8

TPMT LU		Stock							Dimensions (mm)					
		AC810P	AC820P	AC630M	AC6030M	AC6040M	AC530U	T1500Z	T3000Z	T1000A	T1500A	Inscribed circle	Thickness	Nose Radius
Cat. No.														
TPMT 080202N-LU				●	●	●	●	●	●	●	●	4.76	2.38	0.2
080204N-LU				●	●	●	●	●	●	●	●			0.4
TPMT 090202N-LU			●									5.56	2.38	0.2
090204N-LU			●											0.4
TPMT 110302N-LU				●	●	●	●	●	●	●	●	6.35	3.18	0.2
110304N-LU				●	●	●	●	●	●	●	●			0.4
110308N-LU				●	●	●	●	●	●	●	●			0.8

TPMT FK		Stock				Dimensions (mm)		
		T1000A	T1500A			Inscribed circle	Thickness	Nose Radius
Cat. No.								
TPMT 110308N-FK		●	●			6.35	3.18	0.8
TPMT 160404N-FK		●	●			9.525	4.76	0.4
160408N-FK		●	●					0.8

## ● 11° Relief M-Class

TPMT LB		Stock						Dimensions (mm)		
		AC820P	AC830P	AC6030M	AC6040M	T1500Z	T3000Z	T1500A	Inscribed circle	Thickness
Cat. No.										
TPMT 090202N-LB		●	●	●	●	●	●	5.56	2.38	0.2
090204N-LB		●	●	●	●	●	●			0.4
TPMT 110302N-LB		●	●	●	●	●	●	6.35	3.18	0.2
110304N-LB		●	●	●	●	●	●			0.4
110308N-LB		●	●	●	●	●	●			0.8

TPMT SU		Stock										Dimensions (mm)				
		AC810P	AC820P	AC830P	AC610M	AC630M	AC6030M	AC6040M	AC530U	T1500Z	T3000Z	T1000A	T1500A	Inscribed circle	Thickness	Nose Radius
Cat. No.																
TPMT 080202N-SU						●	●	●	●	●	●	●	●	4.76	2.38	0.2
080204N-SU						●	●	●	●	●	●	●	●			0.4
TPMT 110302N-SU		●	●	●	●	●	●	●	●	●	●	●	●	6.35	3.18	0.2
110304N-SU		●	●	●	●	●	●	●	●	●	●	●	●			0.4
110308N-SU		●	●	●	●	●	●	●	●	●	●	●	●			0.8
TPMT 160404N-SU		●	●	●	●	●	●	●	●	●	●	●	●	9.525	4.76	0.4
160408N-SU		●	●	●	●	●	●	●	●	●	●	●	●			0.8

TPMT MU		Stock								Dimensions (mm)		
		AC810P	AC820P	AC2000	AC630M	AC6030M	AC405K	AC415K	AC420K	AC410K	Inscribed circle	Thickness
Cat. No.												
TPMT 110304N-MU		●	●	▲	●	●	●	●	▲	6.35	3.18	0.4
110308N-MU		●	●	▲	●	●	●	●	▲			0.8
TPMT 160404N-MU		●	●	▲	●	●	●	●	▲	9.525	4.76	0.4
160408N-MU		●	●	▲	●	●	●	●	▲			0.8

TPMH TPMT SF		Stock				Dimensions (mm)		
		AC820P	AC830P	AC2000			Inscribed circle	Thickness
Cat. No.								
TPMH 110304N-SF		●	●	▲		6.35	3.18	0.4
110308N-SF		●	●	▲				0.8
TPMT 160404N-SF		●	●	▲		9.525	4.76	0.4
160408N-SF		●	●	▲				0.8



# SEC-Boring Bars STUP/STUB Type

■ Insert ( ■ SUMIBORON)

● 5°/11° Relief E/G-Class

● SUMIBORON One-use Type

(●▲: 1pc. per package stock, ●▲: 1pc. per package and 10pc. per package stock)

NU-TBEW NU-TPGW	Stock							Dimensions (mm)						
	BNX10	BNX20	BNX25	BN1000	BN2000	BN250	BN350	BN500	BN7000	Inscribed circle	Thickness	Nose Radius		
Cat. No.														
NU-TBEW 060102LT	●									3.97	1.59	0.2		
NU-TPGW 080202		●								4.76	2.38	0.2		
080204			●									0.4		
080208				●								0.8		
080204LF					▲							0.4		
080202LT						▲						0.2		
080204LT							▲					0.4		
080202LS								▲				0.2		
080204LS									▲			0.4		
080208LS												0.8		
080202HS												0.2		
080204HS												0.4		
080208HS												0.8		
NU-TPGW 110302	●	●		●	▲	●	●	●	●			6.35	3.18	0.2
110304	●	●		●	▲	●	●	●	●					0.4
110308	●	●		●	▲	●	●	●	●					0.8
NS-TPGW 110304			●							0.4				
110308			●							0.8				
NU-TPGW 110302LF										0.2				
110304LF										0.4				
110308LF										0.8				
110302LT		●			▲					0.2				
110304LT		●			▲					0.4				
110308LT		●			▲					0.8				
110302LS								▲		0.2				
110304LS									▲	0.4				
110308LS										0.8				
110302HS										0.2				
110304HS										0.4				
110308HS										0.8				
NU-TPGW 160404	●	●		●	▲	●	●	●	●	9.525	4.76	0.4		
160408	●	●		●	▲	●	●	●	●			0.8		
NS-TPGW 160404			●									0.4		
160408			●									0.8		
NU-TPGW 160404LF												0.4		
160404LT		●			▲							0.4		
160408LT		●			▲							0.8		
160404LS								▲				0.4		
160408LS									▲			0.8		
160404HS												0.4		
160408HS												0.8		

\* LF: for sintered component and cast iron machining LT: for fine boring of hardened steel  
LS: Continuous cutting HS: for Strong Edge Type

● 11° Relief M-Class

● Coated SUMIBORON One-use Type/Multi corner

3NC-TPGW	Stock						Dimensions (mm)		
	BNC2010	BNC2020	BNC100	BNC160	BNC200	BNC300	Inscribed circle	Thickness	Nose Radius
Cat. No.									
3NC-TPGW 110302	●	●					6.35	3.18	0.2
110304	●	●							0.4
110308	●	●							0.8
110304LS			●						0.4
110308LS			●						0.8
110304HS				●					0.4
110308HS					●				0.8
3NC-TPGW 160404	●	●				●	9.525	4.76	0.4
160408	●	●				●			0.8
160404LS			●						0.4
160408LS			●						0.8
160404HS				●					0.4
160408HS					●				0.8

\* LS: for fine boring of hardened steel HS: for Strong Edge Type

● Coated SUMIBORON Break Master

3NC-TPGT FV	Stock				Dimensions (mm)		
	BNC160	BNC200	BNC2010	BNC2020	Inscribed circle	Thickness	Nose Radius
Cat. No.							
3NC-TPGT 110304N-FV	●	●	●	●	6.35	3.18	0.4
110308N-FV	●	●	●	●			0.8

● Uncoated SUMIBORON One-use Type/Multi corner

3NU-TPGW	Stock				Dimensions (mm)		
	BN7000	BN7500			Inscribed circle	Thickness	Nose Radius
Cat. No.							
3NU-TPGW 110304	●	●			6.35	3.18	0.4
110308	●	●					0.8
110302LF	●	●					0.2
110304LF	●	●					0.4
110308LF	●	●					0.8
110304LE	●	●					0.4
110304LS	●	●					0.4

\* LF/LE: for sintered component and cast iron machining LS: Continuous cutting

● Uncoated SUMIBORON Break Master

3NU-TPGT FV	Stock				Dimensions (mm)		
	BN2000				Inscribed circle	Thickness	Nose Radius
Cat. No.							
3NU-TPGT 110304N-FV	●				6.35	3.18	0.4
110308N-FV	●						0.8

● SUMIBORON

TPGW	Stock						Dimensions (mm)		
	BNX20	BN2000	BN250	BN500	BN7000	BN700	Inscribed circle	Thickness	Nose Radius
Cat. No.									
TPGW 110304	●	●	▲	▲	●	●	6.35	3.18	0.4
110308	●	●	▲	▲	●	●			0.8
110304HS	—	—	—	—	—	—			0.4
110308HS	—	—	—	—	—	—			0.8
TPGW 160404	●	●	▲	▲	—	—	9.525	4.76	0.4
160408	—	—	▲	▲	—	—			0.8
160404HS	—	—	—	—	—	—			0.4
160408HS	—	—	—	—	—	—			0.8

\* HS: for Strong Edge Type

▲ mark : To be replaced by new item (Please confirm stock availability)

# SEC-Boring Bars STUP/STUB Type



■ Insert (SUMIDIA)

- SUMIDIA 5°/11° Relief M/G-Class
- SUMIDIA NF Type

NF-TBGW NF-TPGW		Stock				Dimensions (mm)		
		DA1000	DA2200			Inscribed circle	Thickness	Nose Radius
Cat. No.								
NF-TBGW 060102	● ▲					3.97	1.59	0.2
060104	● ▲							0.4
NF-TPGW 080201	● ▲					4.76	2.38	0.1
080202	● ▲							0.2
080204	● ▲							0.4
NF-TPGW 110301	● ▲					6.35	3.18	0.1
110302	● ▲							0.2
110304	● ▲							0.4
110308	● ▲							0.8
NF-TPGW 160401	● ▲					9.525	4.76	0.1
160402	● ▲							0.2
160404	● ▲							0.4
160408	● ▲							0.8

- SUMIDIA 5°/11° Relief M/G-Class
- SUMIDIA

TBGW TPGW		Stock				Dimensions (mm)		
		DA150				Inscribed circle	Thickness	Nose Radius
Cat. No.								
TBGW 060102	●					3.97	1.59	0.2
060104	●							0.4
TPGW 080202	●					4.76	2.38	0.2
080204	●							0.4
TPGW 110302	●					6.35	3.18	0.2
110304	●							0.4
110308	●							0.8
TPGW 160402	●					9.525	4.76	0.2
160404	●							0.4
160408	●							0.8

- SUMIDIA NF Type

NF-TPMT		Stock				Dimensions (mm)		
		DA1000	DA2200			Inscribed circle	Thickness	Nose Radius
Cat. No.								
NF-TPMT 110301	● ▲					6.35	3.18	0.1
110302	● ▲							0.2
110304	● ▲							0.4
110308	● ▲							0.8

- SUMIDIA (Break Master)

NF-TPMT LD/GD		Stock				Dimensions (mm)		
		DA1000				Inscribed circle	Thickness	Nose Radius
Cat. No.								
NEW NF-TPMT 080202N-LD	●					4.76	2.38	0.2
NEW 080204N-LD	●							0.4
NEW 080202N-GD	●							0.2
NEW 080204N-GD	●							0.4
NEW NF-TPMT 090202N-LD	●					5.56	2.38	0.2
NEW 090204N-LD	●							0.4
NEW 090202N-GD	●							0.2
NEW 090204N-GD	●							0.4
NEW NF-TPMT 110302N-LD	●					6.35	3.18	0.2
NEW 110304N-LD	●							0.4
NEW 110308N-LD	●							0.8
NEW 110302N-GD	●							0.2
NEW 110304N-GD	●							0.4
NEW 110308N-GD	●							0.8
NEW NF-TPMT 160402N-LD	●					9.525	4.76	0.2
NEW 160404N-LD	●							0.4
NEW 160408N-LD	●							0.8
NEW 160402N-GD	●							0.2
NEW 160404N-GD	●							0.4
NEW 160408N-GD	●							0.8

\* LD: For Finishing, GD: For Medium Finishing

- SUMIDIA (Break Master)

NU-TPMT DM		Stock				Dimensions (mm)		
		DA150				Inscribed circle	Thickness	Nose Radius
Cat. No.								
NU-TPMT 080202L-DM	●					4.76	2.38	0.2
080204L-DM	●							0.4
NU-TPMT 110302L-DM	●					6.35	3.18	0.2
110304L-DM	●							0.4
NU-TPMT 160402L-DM	▲					9.525	4.76	0.2
160404L-DM	▲							0.4

▲ mark : To be replaced by new item (Please confirm stock availability)

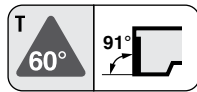
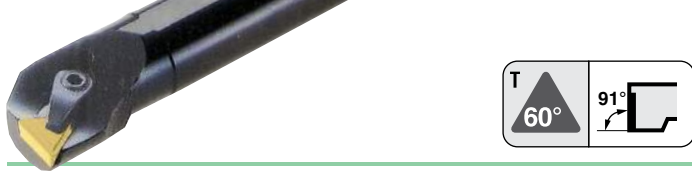

# SEC-Boring Bars S-CTFP Type

## General Boring (Top Clamp Type)

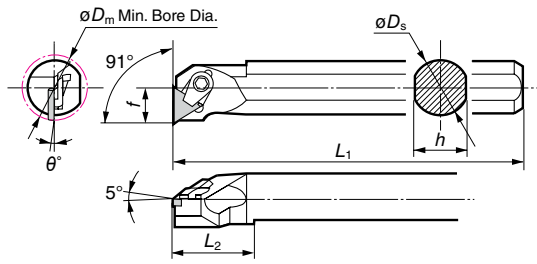
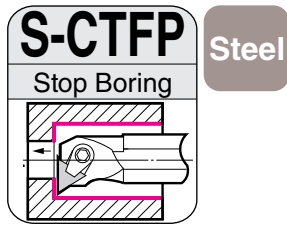

■ Holder Right handed toolholders are applicable with left handed or neutral inserts.  
Left handed toolholders are applicable with right handed or neutral inserts.

Above figures show right hand tools.

### ■ Spare Parts

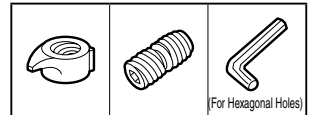

Shank	Cat. No.	Conventional Cat. No.	Stock		Dimensions (mm)							Applicable Insert	Clamp	Double Screw	Wrench
			R	L	$\phi D_m$	$\phi D_s$	$h$	$L_1$	$f$	$L_2$	$\theta^\circ$				
Steel	S12M-CTFP R/L1103-16	S12M-CTFP R/L11	●	●	16	12	11	150	8.0	17	-6	TP □□ 1103□□	CCM5BSL/R (R: Made to order)	WB5-10	LH025
	S16Q-CTFP R/L1103-20	S16Q-CTFP R/L11	●	●	20	16	15	180	10.0	18	-4				
	S20R-CTFP R/L1103-25	S20R-CTFP R/L11	●	●	25	20	18	200	12.5	18	-2				
	S25S-CTFP R/L1603-32	S25S-CTFP R/L16	●	●	32	25	23	250	16.0	38	-2				

■ Insert ( Coated / Cermet / Carbide / SUMIBORON)

### ● 11° Relief G-Class

TPGR W	Cat. No.	Stock					Dimensions (mm)				
		T1500Z	T1000A	T1500A	T110A	T1200A	ST10P	Inscribed circle	Thickness	Nose Radius	
TPGR 110302R-W		●	●	●							0.2
110302L-W		●	●	●							0.2
110304R-W		●	●	●		▲		6.35	3.18		0.4
110304L-W		●	●	●		▲					0.4
110308L-W		●	●	●		▲					0.8
TPGR 160302R-W		●	●	●							0.2
160302L-W		●	●	●							0.2
160304R-W		●	●	●		▲		9.525	3.18		0.4
160304L-W		●	●	●		▲					0.4
160308R-W		●	●	●		▲					0.8
160308L-W		●	●	●		▲					0.8

### ● 11° Relief G-Class

#### ● SUMIBORON

TPGN	Cat. No.	Stock						Dimensions (mm)			
		BNX20	BN2000	BN250	BN500	BN7000	BN700	Inscribed circle	Thickness	Nose Radius	
TPGN 110304		●	●	▲				6.35	3.18		0.4
110308		●	●	▲							0.8
TPGN 110304HS		—	—	—	—	—	—				0.4
110308HS		—	—	—	—	—	—				0.8
TPGN 160304		●	●	▲	●	●	●	9.525	3.18		0.4
160308		●	●	▲	●	●	●				0.8
TPGN 160304HS		—	—	—	—	—	—				0.4
160308HS		—	—	—	—	—	—				0.8

\* HS: for Strong Edge Type

TPGN	Cat. No.	Stock							Dimensions (mm)				
		AC510U	T1000A	T1500A	ST20E	A30	G10E	H1	NB90S	NB100C	Inscribed circle	Thickness	Nose Radius
TPGN 110302		●	●	●				●			6.35	3.18	0.2
110304		●	●	●				●					0.4
110308		●	●	●				●					0.8
TPGN 160302		●	●	●				●					0.2
160304		●	●	●				●			9.525	3.18	0.4
160308		●	●	●				●					0.8
160312		●	●	●				●					1.2

### ● 11° Relief M-Class

#### ● SUMIBORON One-use Type (●: 1pc. per package stock, ●: 1pc. per package and 10pc. per package stock)

NU-TPGN	Cat. No.	Stock							Dimensions (mm)				
		BNX20	BN1000	BN2000	BN250	BN350	BN500	BN7000	BN700	Inscribed circle	Thickness	Nose Radius	
NU-TPGN 110302		●	●	●									0.2
110304		●	●	●	▲	●	●	●	●				0.4
110308		●	●	●	▲	●	●	●	●				0.8
110302LT		—	—	—	—	—	—	—	—				0.2
110304LT		—	—	—	—	—	—	—	—				0.4
110308LT		—	—	—	—	—	—	—	—				0.8
110302LS		—	—	—	—	—	—	—	—				0.2
110304LS		—	—	—	—	—	—	—	—				0.4
110308LS		—	—	—	—	—	—	—	—				0.8
110304HS		—	—	—	—	—	—	—	—				0.4
110308HS		—	—	—	—	—	—	—	—				0.8
NU-TPGN 160302		●	●	●									0.2
160304		●	●	●	▲	●	●	●	●				0.4
160308		●	●	●	▲	●	●	●	●				0.8
160304LT		—	—	—	—	—	—	—	—				0.4
160308LT		—	—	—	—	—	—	—	—				0.8
160302LS		—	—	—	—	—	—	—	—				0.2
160304LS		—	—	—	—	—	—	—	—				0.4
160308LS		—	—	—	—	—	—	—	—				0.8
160304HS		—	—	—	—	—	—	—	—				0.4
160308HS		—	—	—	—	—	—	—	—				0.8

\* LT: for fine boring of hardened steel LS: Continuous cutting HS: for Strong Edge Type

# SEC-Boring Bars CTFP Type



■ Insert ( Coated / Cermet / Carbide / SUMIDIA)

● SUMIDIA NF Type

NF-TPGN		Stock						Dimensions (mm)		
		DA1000	DA2200					Inscribed circle	Thickness	Nose Radius
Cat. No.										
NF-TPGN 110302		●▲						6.35	3.18	0.2
110304		●▲						6.35	3.18	0.4
110308		●▲						6.35	3.18	0.8
NF-TPGN 160302		●▲						9.525	3.18	0.2
160304		●▲						9.525	3.18	0.4
160308		●▲						9.525	3.18	0.8

NF-TPGN		Stock						Dimensions (mm)		
		DA1000	DA2200					Inscribed circle	Thickness	Nose Radius
Cat. No.										
NF-TPGN 110304P		●▲						6.35	3.18	0.4
110308P		●▲						6.35	3.18	0.8
NF-TPGN 160304P		●▲						9.525	3.18	0.4

● SUMIDIA

TPGN		Stock						Dimensions (mm)		
		DA150						Inscribed circle	Thickness	Nose Radius
Cat. No.										
TPGN 110302		●						6.35	3.18	0.2
110304		●						6.35	3.18	0.4
110308		●						6.35	3.18	0.8
TPGN 160302		●						9.525	3.18	0.2
160304		●						9.525	3.18	0.4
160308		●						9.525	3.18	0.8

● 11° Relief M-Class

TPMR FK		Stock						Dimensions (mm)		
		T1500Z	T3000Z	T2000Z	T1000A	T1500A	T110A	T1200A	Inscribed circle	Thickness
Cat. No.										
TPMR 110302N-FK		●			●	●	▲	6.35	3.18	0.2
110304N-FK		●	●	▲	●	●	▲	6.35	3.18	0.4
110308N-FK		●	●	▲	●	●	▲	6.35	3.18	0.8
TPMR 160304N-FK		●	●	▲	●	●	▲	9.525	3.18	0.4
160308N-FK		●	●	▲	●	●	▲	9.525	3.18	0.8
160312N-FK		●	●	▲	●	●	▲	9.525	3.18	1.2

TPMR SF		Stock				Dimensions (mm)					
		AC820P	AC830P	AC2000	ST10P				Inscribed circle	Thickness	Nose Radius
Cat. No.											
TPMR 110304N-SF		●	●	▲	●				6.35	3.18	0.4
110308N-SF		●	●	▲	●				6.35	3.18	0.8
TPMR 160304N-SF		●	●	▲	●				9.525	3.18	0.4
160308N-SF		●	●	▲	●				9.525	3.18	0.8
160312N-SF		●	●	▲	●				9.525	3.18	1.2

TPMR UJ		Stock				Dimensions (mm)					
		AC820P	AC830P	AC2000					Inscribed circle	Thickness	Nose Radius
Cat. No.											
TPMR 110304N-UJ		●	●	▲					6.35	3.18	0.4
110308N-UJ		●	●	▲					6.35	3.18	0.8
TPMR 160304N-UJ		●	●	▲					9.525	3.18	0.4
160308N-UJ		●	●	▲					9.525	3.18	0.8

TPMN		Stock								Dimensions (mm)			
		AC405K	AC415K	AC420K	AC510U	T1000A	T1500A	ST10P	ST20E	A30	G10E	Inscribed circle	Thickness
Cat. No.													
TPMN 110304		●	●	●	●					●	6.35	3.18	0.4
110308		●	●	●	●					●	6.35	3.18	0.8
TPMN 160304		●	●	●	●			●	●	●	9.525	3.18	0.4
160308		●	●	●	●		▲	●	●	●	9.525	3.18	0.8
160312		●	●	●	●		▲	●	●	●	9.525	3.18	1.2

● 11° Relief M-Class

● SUMIDIA (Break Master)

NU-TPMR DM		Stock						Dimensions (mm)		
		DA150						Inscribed circle	Thickness	Nose Radius
Cat. No.										
NU-TPMR 110302L-DM		●						6.35	3.18	0.2
110304L-DM		●						6.35	3.18	0.4
NU-TPMR 160302L-DM		●						9.525	3.18	0.2
160304L-DM		●						9.525	3.18	0.4





# SEC-Boring Bars S-PTFN/B-PTFN Type

## General Boring

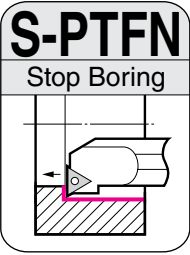

Steel

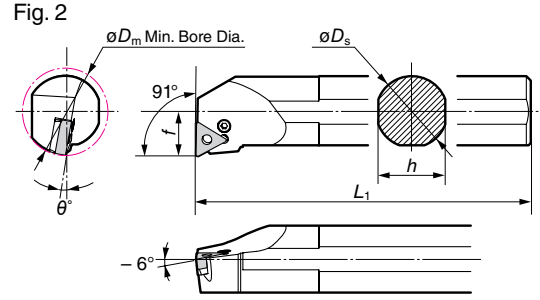
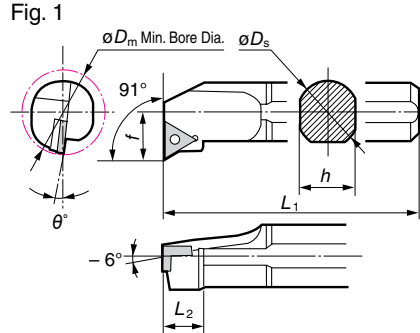

### ■ Spare Parts

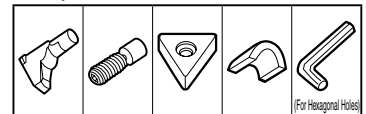

■ Holder Right handed toolholders are applicable with left handed or neutral inserts.  
Left handed toolholders are applicable with right handed or neutral inserts.

Above figures show right hand tools.

Shank	Cat. No.	Stock		Dimensions (mm)							Fig.	Applicable Insert Cat. No.	Lever Pin	Clamp Bolt	Shim	Shim Pin	Wrench		
		R	L	$\theta D_m$	$\theta D_s$	$h$	$L_1$	$f$	$L_2$	$\theta^\circ$									
Steel	S25R-PTFN R/L1604-32	—	—	32	25	23	200	16.0	21.5	-12	1	TN□□1604□□	From B54	LCL3	LCS3	LST317CA	LSP3	LH025	
	S32S-PTFN R/L1604-40	—	—	40	32	30	250	20.0	21.0	-10									
	S32S-PTFN R/L1604-44	S32S-PTFN R/L16	●	●	44	32	30	250	22.0	21.0									-10
	S40T-PTFN R/L1604-50	—	—	50	40	37	300	25.0	21.0	-10									
	S50U-PTFN R/L1604-63	—	—	63	50	47	350	31.5	—	-10									
	S40T-PTFN R/L2204-54	S40T-PTFN R/L22	●	●	54	40	37	300	27.0	26.0	-10	1	TN□□2204□□	B59	LCL4	LCS4	LST42	LSP4	LH030
S50U-PTFN R/L2204-70	S50U-PTFN R/L22	●	●	70	50	47	350	35.0	33.0	-10									

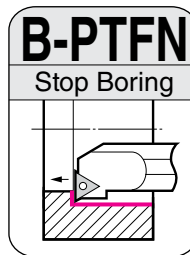

Anti-vibration

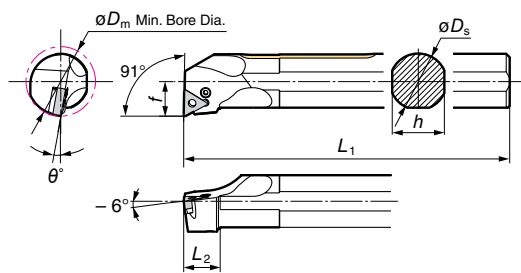

### ■ Insert

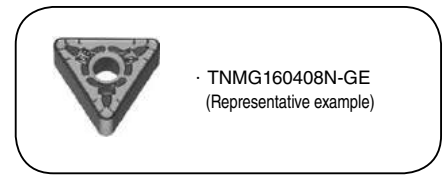

### ■ Spare Parts

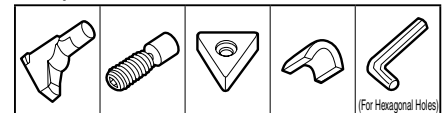

■ Holder Right handed toolholders are applicable with left handed or neutral inserts.  
Left handed toolholders are applicable with right handed or neutral inserts.

Above figures show right hand tools.

Shank	Cat. No.	Stock		Dimensions (mm)							Applicable Insert		Lever Pin	Clamp Bolt	Shim	Shim Pin	Wrench
		R	L	$\theta D_m$	$\theta D_s$	$h$	$L_1$	$f$	$L_2$	$\theta^\circ$	Cat. No.	Featured page					
Anti-vibration	B25T-PTFN R/L1604-32	●	—	32	25	23	300	16	21	-12	TN□□1604□□	From B54	LCL3	LCS3	LST317CA	LSP3	LH025
	B32U-PTFN R/L1604-40	●	—	40	32	30	350	20	21	-10							
	B40W-PTFN R/L1604-50	●	—	50	40	37	450	25	21	-10							

# SEC-Boring Bars S-DTFN/D-DTFN Type

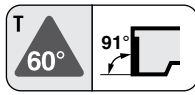

## General Boring

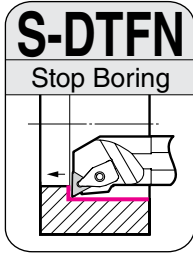

Steel

New

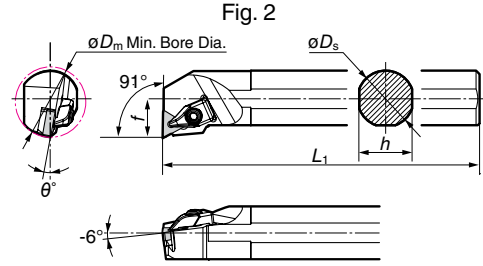
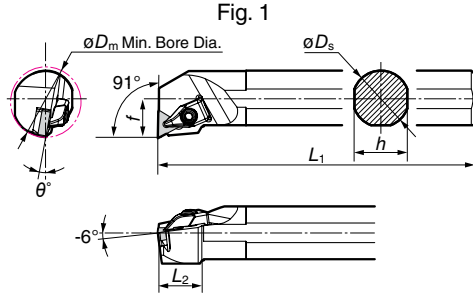

■ Holder Right handed toolholders are applicable with left handed or neutral inserts.  
Left handed toolholders are applicable with right handed or neutral inserts.

Above figures show right hand tools.

Shank	Cat. No.	Stock		Min. Bore Dia.	Dimensions (mm)						Fig.	Applicable Insert Cat. No.	Featured page	Clamp Set	Recommended Tightening Torque (N·m)	Shim	Shim Screw	Wrench for Upper Surface	Wrench for Lower Surface
		R	L		øD <sub>m</sub>	øD <sub>s</sub>	h	L <sub>1</sub>	f	L <sub>2</sub>									
Steel	S32S-DTFN R/L1604-40	●	●	40	32	30	250	22.0	26	-10	1	TN □□1604□□	From B54	SCP-1	5.0	TNS1604B	BFTX0307N	LH040	LH025
Steel	S40T-DTFN R/L1604-50	●	●	50	40	37	300	27.0	26	-10	1	TN □□1604□□	From B54	SCP-1	5.0	TNS1604B	BFTX0307N	LH040	LH025
Steel	S50U-DTFN R/L1604-63	●	●	63	50	47	350	31.5	—	-10	2	TN □□1604□□	From B54	SCP-1	5.0	TNS1604B	BFTX0307N	LH040	LH025

### ■ Spare Parts

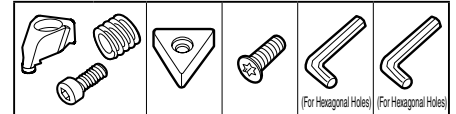

Clamp Set Parts E77

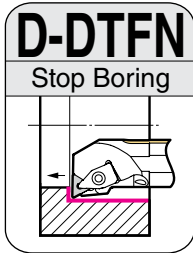

Anti-vibration with oil hole

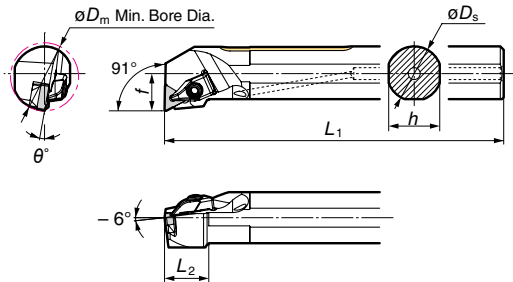

SumiTurn Bar

### ■ Insert

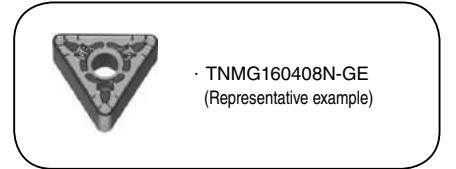

### ■ Spare Parts

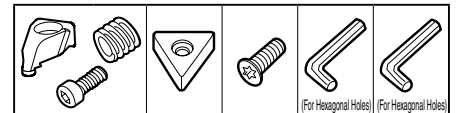

■ Holder Right handed toolholders are applicable with left handed or neutral inserts.  
Left handed toolholders are applicable with right handed or neutral inserts.

Above figures show right hand tools.

Shank	Cat. No.	Stock		Min. Bore Dia.	Dimensions (mm)						Applicable Insert Cat. No.	Featured page	Clamp Set	Recommended Tightening Torque (N·m)	Shim	Shim Screw	Wrench for Upper Surface	Wrench for Lower Surface
		R	L		øD <sub>m</sub>	øD <sub>s</sub>	h	L <sub>1</sub>	f	L <sub>2</sub>								
Anti-vibration With oil hole	D25T-DTFN R/L1604-32	●	●	32	25	23	300	17	21	-12	TN □□1604□□	From B54	SCP-1	5.0	TNS1603B	BFTX0307N	LH040	LH025
	D32T-DTFN R/L1604-40	●	●	40	32	30	300	22	26	-10					TNS1604B			
	D40U-DTFN R/L1604-50	●	●	50	40	37	350	27	26	-10								

Clamp Set Parts E77



# SEC-Boring Bars/SUMIBORON Small Hole Boring Bars S-ETFN/BNZ Type

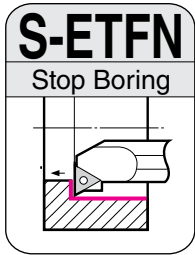

Steel

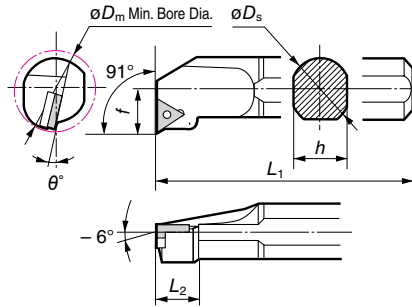

### Insert

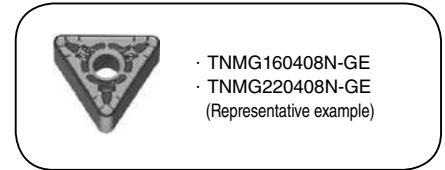

### Spare Parts

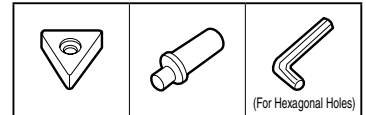

■ Holder Right handed toolholders are applicable with left handed or neutral inserts.  
Left handed toolholders are applicable with right handed or neutral inserts.

Above figures show right hand tools.

Shank	Cat. No.	Conventional Cat. No.	Stock		Dimensions (mm)							Applicable Insert		Shim	Pin	Wrench
			R	L	$\theta D_m$	$\theta D_s$	$h$	$L_1$	$f$	$L_2$	$\theta^\circ$	Cat. No.	Featured page			
Steel	S25R-ETFN R/L1604-34	BTFN325 R/L	●		34	25	23	200	17	18	-12	TN □□1604□□	From B54	STW323	CPB34 CPB35	LH025
	S32S-ETFN R/L1604-44	BTFN332 R/L	●		44	32	30	250	22	20	-10					
	S40T-ETFN R/L2204-54	BTFN440 R/L	●		54	40	37	300	27	25	-10	TN □□2204□□	B59	STW434	CPB44T CPB45T	LH030
	S50U-ETFN R/L2204-70	BTFN450 R/L	●		70	50	47	350	35	32	-10					

## SUMIBORON

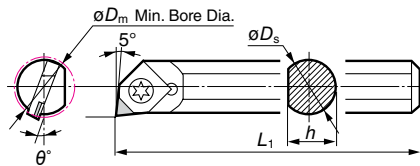
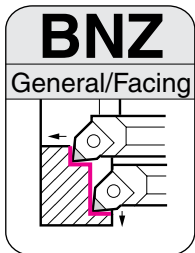

Sumi Small

### Spare Parts

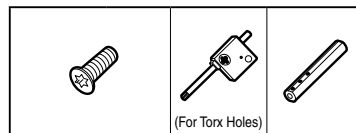

### Holder

Cat. No.	Stock	Dimensions (mm)					Screw	Recommended Tightening Torque (N·m)	Wrench	Adaptor Sleeve
		$\theta D_m$	$\theta D_s$	$h$	$L_1$	$\theta^\circ$				
BNZ 606R	●	7.0	6.0	5.5	80	-14	BFTX0204N	0.5	TRX06	HBB 616
BNZ 608R	●	9.0	8.0	7.5	100	-12				HBB 816
BNZ 610R	●	11.0	10.0	9.5	125	-10				—
BNZ 612R	●	13.0	12.0	11.0	130	-8				—
BNZ 616R	●	17.0	16.0	15.0	145	-6				—
BNZ 620R	●	21.0	20.0	19.0	160	-5				—

Sleeve		Stock	$\theta D_s$	Applicable Holder
$\phi 16$	$\phi D_s$	●	6	BNZ 606R
15	100	●	8	BNZ 608R

### Insert (SUMIBORON)

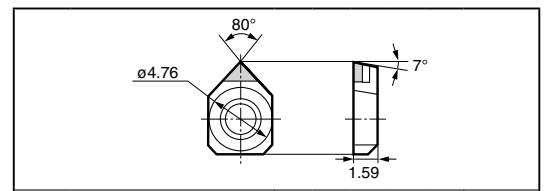

Cat. No.	Stock					Dimensions (mm)
	BN1000	BN2000	BN250	BN7000	BN700	
1pc pack	●	●	▲	●	●	Nose Radius
10pc pack	●	●	▲	●	●	

# SEC-Boring Bars S-SCLC/B-SCLC Type

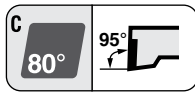

## Finish-Medium Cut

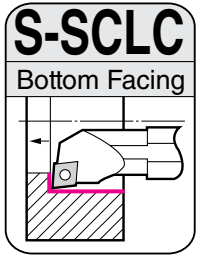

**Steel**

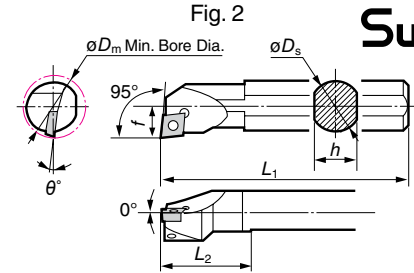
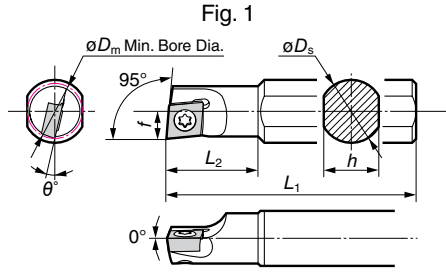

**Sumi Small**

### ■ Spare Parts

**■ Holder** Right handed toolholders are applicable with left handed or neutral inserts.  
Left handed toolholders are applicable with right handed or neutral inserts.

Above figures show right hand tools.

Shank	Cat. No.	Conventional Cat. No.	Stock		Min. Bore Dia.	Dimensions (mm)						Fig.	Applicable Insert	Screw	Recommended Tightening Torque (N·m)	Wrench		
			R	L		$\phi D_m$	$\phi D_s$	$h$	$L_1$	$f$	$L_2$						$\theta^\circ$	
Steel	S08H-SCLC R/L03X1-05	—			5	8	7	100	2.5	24	-15	1	CC □□03X1□□	BFTX016033	0.2	TRX06		
	S08H-SCLC R/L03X1-06	—			6	8	7	100	3.0	28	-13							
	S08H-SCLC R/L04X1-07	—			7	8	7	100	3.5	32	-13	1	CC □□04X1□□	BFTX0203N	0.5			
	S08H-SCLC R/L04X1-08	—			8	8	7	100	4.0	37	-11							
	S08H-SCLC R/L0602-10	S08H-SCLC R/L06	●	●	10	8	7	100	5.5	19	-13			BFTX02505N	1.1	TRX08		
	S10K-SCLC R/L0602-12	S10K-SCLC R/L06-12	●	●	12	10	9	125	6.0	21	-12							
	S10K-SCLC R/L0602-13	S10K-SCLC R/L06	▲	▲	13	10	9	125	7.0	21	-12	2	CC □□0602□□					
	S12M-SCLC R/L0602-14	S12M-SCLC R/L06-14	●	●	14	12	11	150	7.0	25	-10			BFTX02506N	1.5			
	S12M-SCLC R/L0602-16	S12M-SCLC R/L06	▲	▲	16	12	11	150	9.0	25	-10							
	S16R-SCLC R/L0602-18	—		●	●	18	16	15	200	9.0	27	-8						
	S16R-SCLC R/L09T3-18	—		●	●	18	16	15	200	9.0	30	-10						
	S16R-SCLC R/L09T3-20	S16R-SCLC R/L09	▲	▲	20	16	15	200	11.0	30	-8			BFTX0407N	3.0		TRX15	
	S20S-SCLC R/L09T3-22	—		●	●	22	20	18	250	11.0	30	-8	2	CC □□09T3□□				
	S20S-SCLC R/L09T3-25	S20S-SCLC R/L09	▲	▲	25	20	18	250	13.0	30	-7			BFTX0409N	3.4	TRX15		
	S25T-SCLC R/L09T3-27	—		●	●	27	25	23	300	13.5	35	-6						
S25T-SCLC R/L1204-32	S25T-SCLC R/L12	▲	▲	32	25	23	300	17.0	38	-6	2	CC □□1204□□	BFTX0511N	5.0	TRX20			

### ■ Spare Parts

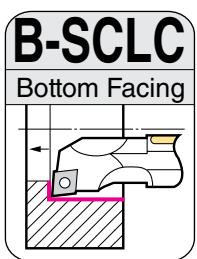

**Anti-vibration**

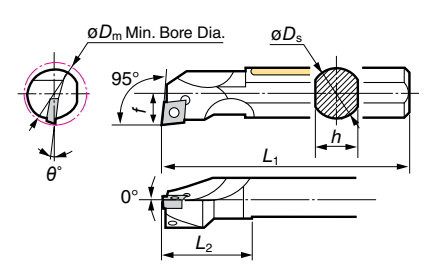

**SumiTurn**

**Sumi Small**

**■ Holder** Right handed toolholders are applicable with left handed or neutral inserts.  
Left handed toolholders are applicable with right handed or neutral inserts.

Above figures show right hand tools.

Shank	Cat. No.	Stock		Min. Bore Dia.	Dimensions (mm)						Applicable Insert	Screw	Recommended Tightening Torque (N·m)	Wrench		
		R	L		$\phi D_m$	$\phi D_s$	$h$	$L_1$	$f$	$L_2$					$\theta^\circ$	
Anti-vibration	B08H-SCLC R/L0602-10	●	●	10	8	7	100	5.5	19	-13			BFTX02505N	1.1	TRX08	
	B10K-SCLC R/L0602-12	●	●	12	10	9	125	6.0	21	-12						
	B12M-SCLC R/L0602-14	●	●	14	12	11	150	7.0	25	-10			BFTX02506N	1.5		
	B12M-SCLC R/L0602-16	●	●	16	12	11	150	9.0	25	-10						
	B16R-SCLC R/L09T3-20	—	●	●	20	16	15	200	11.0	30	-8			BFTX0407N	3.0	TRX15
	B20S-SCLC R/L09T3-25	—	●	●	25	20	18	250	13.0	30	-7			BFTX0409N	3.4	TRX15
	B25T-SCLC R/L1204-32	—	●	●	32	25	23	300	17.0	38	-6			CC □□1204□□	BFTX0511N	5.0

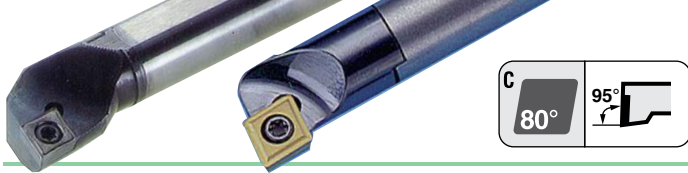

# SEC-Boring Bars C-SCLC/E-SCLC Type

## Finish-Medium Cut

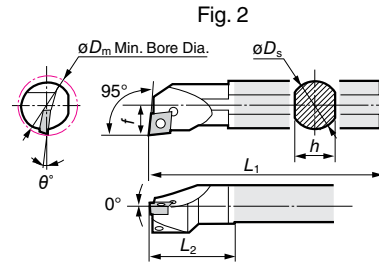
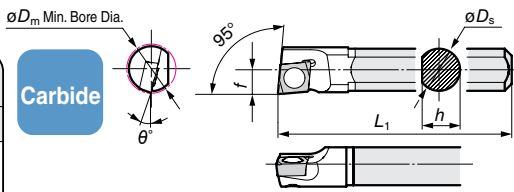
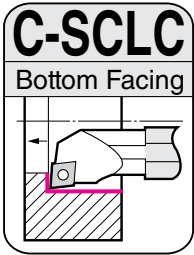

Sumi Small

■ Holder Right handed toolholders are applicable with left handed or neutral inserts.

Shank	Cat. No.	Conventional Cat. No.	Stock R	Min. Bore Dia. $\phi D_m$	Dimensions (mm)						Fig.	Applicable Insert	Screw	Recommended Tightening Torque (N·m)	Wrench
					$\phi D_s$	$h$	$L_1$	$f$	$L_2$	$\theta^\circ$					
Carbide	C04G-SCLC R03X1-05*	C04G-SCLC R03X1-05*	●	5	4	3.8	90	2.5	—	-15	1	CC □□03X1□□	BFTX016033	0.2	TRX06
	C05H-SCLC R03X1-06*	C05H-SCLC R03X1-06*	●	6	5	4.4	100	3.0	—	-13	1	CC □□04X1□□	BFTX0203N	0.5	TRX06
	C06J-SCLC R04X1-07*	C06J-SCLC R04X1-07*	●	7	6	5.4	110	3.5	—	-13	1	CC □□04X1□□	BFTX02505N	1.1	TRX08
	C07K-SCLC R04X1-08*	C07K-SCLC R04X1-08*	●	8	7	6.4	125	4.0	—	-11	1	BFTX02506N	1.5		
	C08H-SCLC R0602-10	C08H-SCLC R06	●	10	8	7.0	100	5.5	19	-13	2	CC □□0602□□	BFTX0407N	3.4	TRX15
	C10K-SCLC R0602-12	C10K-SCLC R06-12	●	12	10	9.0	125	6.0	21	-12		BFTX0409N	3.4		
	C10K-SCLC R0602-13	C10K-SCLC R06	●	13	10	9.0	125	7.0	21	-12	2	CC □□0602□□	BFTX0407N	3.4	TRX15
	C12M-SCLC R0602-14	C12M-SCLC R06-14	●	14	12	11.0	150	7.0	25	-10	BFTX0409N	3.4			
	C12M-SCLC R0602-16	C12M-SCLC R06	●	16	12	11.0	150	9.0	25	-10	2	CC □□09T3□□	BFTX0407N	3.4	
	C16R-SCLC R09T3-20	C16R-SCLC R09	●	20	16	15.0	200	11.0	30	-8	2	CC □□09T3□□	BFTX0409N	3.4	
C20S-SCLC R09T3-25	C20S-SCLC R09	●	25	20	18.0	250	13.0	35	-7	2	CC □□09T3□□	BFTX0409N	3.4		

\* Requires the separately sold sleeve.

	Sleeve	Stock	$\phi D_s$	Applicable Holder
	HBB 416	●	4	C04G-SCLC R03X1-05*
HBB 516	●	5	C05H-SCLC R03X1-06*	
HBB 616	●	6	C06J-SCLC R04X1-07*	
HBB 716	●	7	C07K-SCLC R04X1-08*	

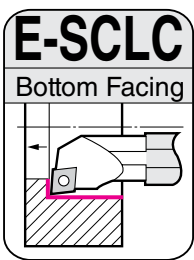

Carbide  
Oil Hole

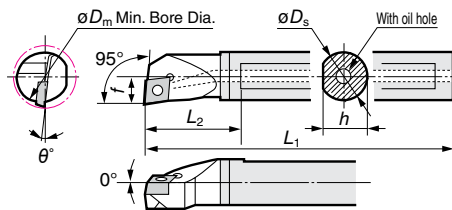

Sumi Small

■ Holder Right handed toolholders are applicable with left handed or neutral inserts.

Shank	Cat. No.	Conventional Cat. No.	Stock R	Min. Bore Dia. $\phi D_m$	Dimensions (mm)						Applicable Insert	Screw	Recommended Tightening Torque (N·m)	Wrench
					$\phi D_s$	$h$	$L_1$	$f$	$L_2$	$\theta^\circ$				
Carbide with oil hole	E08H-SCLC R0602-10	E08H-SCLC R06	●	10	8	7.5	100	5.5	18	-13	CC □□0602□□	BFTX02505N	1.1	TRX08
	E10K-SCLC R0602-13	E10K-SCLC R06	●	13	10	9.5	125	7.0	19	-12		BFTX02506N	1.5	
	E12M-SCLC R0602-16	E12M-SCLC R06	●	16	12	11.5	150	9.0	25	-10	CC □□09T3□□	BFTX0407N	3.4	TRX15
	E16R-SCLC R09T3-20	E16R-SCLC R09	●	20	16	15.5	200	11.0	30	-8		BFTX0409N	3.4	

■ Spare Parts

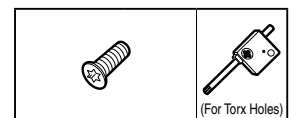

E Boring Bars

# SEC-Boring Bars SCLC Type



■ Insert ( Coated / Cermet / Carbide)

## ● 7° Relief E-Class

CCET FX		Stock					Dimensions (mm)		
		ACZ150					Inscribed circle	Thickness	Nose Radius
Cat. No.									
CCET 0602003R-FX		●					6.35	2.38	0.03
0602003L-FX		●							0.03
060201R-FX		●							0.1
060201L-FX		●							0.1
060202R-FX		●							0.2
060202L-FX		●							0.2
060204R-FX		●					0.4		
060204L-FX		●					0.4		
CCET 09T3003R-FX		●					9.525	3.97	0.03
09T3003L-FX		●							0.03
09T301R-FX		●							0.1
09T301L-FX		●							0.1
09T302R-FX		●							0.2
09T302L-FX		●							0.2
09T304R-FX		●							0.4
09T304L-FX		●							0.4

## ● 7° Relief G-Class

CCGT FC		Stock				Dimensions (mm)		
		AC530U	ACZ150	T1000A	T1500A	Inscribed circle	Thickness	Nose Radius
Cat. No.								
CCGT 060201MN-FC		●	●	●	●	6.35	2.38	<0.1
060202MN-FC		●	●	●	●			<0.2
060204MN-FC		●	●	●	●			<0.4
CCGT 09T301MN-FC		●	●	●	●	9.525	3.97	<0.1
09T302MN-FC		●	●	●	●			<0.2
09T304MN-FC		●	●	●	●			<0.4

Values for nose radius prefixed with "<" mean minus tolerances.

CCET FY		Stock					Dimensions (mm)		
		AC530U	ACZ150	T1000A	T1500A	T1200A	Inscribed circle	Thickness	Nose Radius
Cat. No.									
CCET 03X1003R-FY		●	●	●	●	▲	3.5	1.4	0.03
03X1003L-FY		●	●	●	●	▲			0.03
03X101R-FY		●	●	●	●	▲			0.1
03X101L-FY		●	●	●	●	▲			0.1
03X102R-FY		●	●	●	●	▲			0.2
03X102L-FY		●	●	●	●	▲			0.2
03X104R-FY		●	●	●	●	▲	0.4		
03X104L-FY		●	●	●	●	▲	0.4		
CCET 04X1003R-FY		●	●	●	●	▲	4.3	1.8	0.03
04X1003L-FY		●	●	●	●	▲			0.03
04X101R-FY		●	●	●	●	▲			0.1
04X101L-FY		●	●	●	●	▲			0.1
04X102R-FY		●	●	●	●	▲			0.2
04X102L-FY		●	●	●	●	▲			0.2
04X104R-FY		●	●	●	●	▲	0.4		
04X104L-FY		●	●	●	●	▲	0.4		
CCET 0602003R-FY		●	●	●	●		6.35	2.38	0.03
0602003L-FY		●	●	●	●				0.03
060201R-FY		●	●	●	●				0.1
060201L-FY		●	●	●	●				0.1
060202R-FY		●	●	●	●				0.2
060202L-FY		●	●	●	●				0.2
060204R-FY		●	●	●	●		0.4		
060204L-FY		●	●	●	●		0.4		
CCET 09T3003R-FY		●	●	●	●		9.525	3.97	0.03
09T3003L-FY		●	●	●	●				0.03
09T301R-FY		●	●	●	●				0.1
09T301L-FY		●	●	●	●				0.1
09T302R-FY		●	●	●	●				0.2
09T302L-FY		●	●	●	●				0.2
09T304R-FY		●	●	●	●				0.4
09T304L-FY		●	●	●	●				0.4

CCGT FX		Stock						Dimensions (mm)		
		AC530U	T1500Z	T2000Z	T1000A	T1500A	T110A	T1200A	Inscribed circle	Thickness
Cat. No.										
CCGT 0602003R-FX		●			●	●	▲	6.35	2.38	0.03
0602003L-FX		●			●	●	▲			0.03
060201R-FX		●			●	●	▲			0.1
060201L-FX		●			●	●	▲			0.1
060202R-FX		●			●	●	▲			0.2
060202L-FX		●			●	●	▲			0.2
060204R-FX		●			●	●	▲	0.4		
060204L-FX		●			●	●	▲	0.4		
CCGT 09T3003R-FX		●			●	●	▲	9.525	3.97	0.03
09T3003L-FX		●			●	●	▲			0.03
09T301R-FX		●			●	●	▲			0.1
09T301L-FX		●			●	●	▲			0.1
09T302R-FX		●			●	●	▲			0.2
09T302L-FX		●			●	●	▲			0.2
09T304R-FX		●			●	●	▲			0.4
09T304L-FX		●			●	●	▲			0.4
09T308R-FX		●			●	●	▲			0.8
09T308L-FX		●			●	●	▲	0.8		

CCGT FY		Stock			Dimensions (mm)		
		T1500Z	T1000A	T1500A	Inscribed circle	Thickness	Nose Radius
Cat. No.							
CCGT 03X101R-FY		●	●	●	3.5	1.4	0.1
03X101L-FY		●	●	●			0.1
03X102R-FY		●	●	●			0.2
03X102L-FY		●	●	●			0.2
03X104R-FY		●	●	●			0.4
03X104L-FY		●	●	●			0.4
CCGT 04X101R-FY		●	●	●	4.3	1.8	0.1
04X101L-FY		●	●	●			0.1
04X102R-FY		●	●	●			0.2
04X102L-FY		●	●	●			0.2
04X104R-FY		●	●	●			0.4
04X104L-FY		●	●	●			0.4

CCGT SI		Stock						Dimensions (mm)			
		AC610M	AC630M	AC510U	AC520U	AC530U	T1500Z	T1000A	T1500A	Inscribed circle	Thickness
Cat. No.											
CCGT 09T301MN-SI		●	●	●	●	●	●	●	9.525	3.97	<0.1
09T302MN-SI		●	●	●	●	●	●	●			<0.2
09T304MN-SI		●	●	●	●	●	●	●			<0.4

Values for nose radius prefixed with "<" mean minus tolerances.

## ● 7° Relief G-Class

CCGT AG		Stock					Dimensions (mm)		
		H1					Inscribed circle	Thickness	Nose Radius
Cat. No.									
CCGT 060202N-AG		●					6.35	2.38	0.2
060204N-AG		●							0.4
CCGT 09T302N-AG		●					9.525	3.97	0.2
09T304N-AG		●							0.4
09T308N-AG		●							0.8

▲ mark : To be replaced by new item (Please confirm stock availability)



# SEC-Boring Bars SCLC Type

■ Insert ( Coated / Cermet / Carbide)

### ● 7° Relief G-Class

CCGT SC		Stock						Dimensions (mm)		
		AC530U	ACZ150	T1500Z	T1000A	T1500A	T1200A	Inscribed circle	Thickness	Nose Radius
Cat. No.										
CCGT 060203N-SC		●	●	●	●	●	▲	6.35	2.38	0.03
CCGT 060201MN-SC		●	●	●	●	●	●	6.35	2.38	<0.1
060202MN-SC		●	●	●	●	●	●			<0.2
060204MN-SC		●	●	●	●	●	●			<0.4
CCGT 09T3003N-SC		●	●	●	●	●	▲	9.525	3.97	0.03
CCGT 09T301MN-SC		●	●	●	●	●	●			<0.1
CCGT 09T302MN-SC		●	●	●	●	●	●			<0.2

Values for nose radius prefixed with "<" mean minus tolerances.

CCGT AY		Stock						Dimensions (mm)		
		H1						Inscribed circle	Thickness	Nose Radius
Cat. No.										
CCGT 060201R-AY		●						6.35	2.38	0.1
060201L-AY		●								0.1
060202R-AY		●								0.2
060202L-AY		●								0.2
060204R-AY		●								0.4
060204L-AY		●						0.4		
CCGT 09T301R-AY		●						9.525	3.97	0.1
09T301L-AY		●								0.1
09T302R-AY		●								0.2
09T302L-AY		●								0.2
09T304R-AY		●								0.4
09T304L-AY		●								0.4

### ● 7° Relief M-Class

CCMT FB		Stock					Dimensions (mm)			
		AC530U	T1500Z	T3000Z	T1000A	T1500A	Inscribed circle	Thickness	Nose Radius	
Cat. No.										
CCMT 060202N-FB		●	●	●	●	●	●	6.35	2.38	0.2
060204N-FB		●	●	●	●	●	●	9.525	3.97	0.4
CCMT 09T304N-FB		●	●	●	●	●	●			0.4
09T308N-FB		●	●	●	●	●	●			0.8

CCMT LU		Stock							Dimensions (mm)					
		AC810P	AC820P	AC630M	AC6030M	AC6040M	AC530U	T1500Z	T3000Z	T1000A	T1500A	Inscribed circle	Thickness	Nose Radius
Cat. No.														
CCMT 060202N-LU		●	●	●	●	●	●	●	●	●	●	6.35	2.38	0.2
060204N-LU		●	●	●	●	●	●	●	●	●	●	9.525	3.97	0.4
CCMT 09T304N-LU		●	●	●	●	●	●	●	●	●	●			0.4
09T308N-LU		●	●	●	●	●	●	●	●	●	●			0.8

CCMT LUW		Stock							Dimensions (mm)				
		AC810P	AC820P	AC2000	AC630M	T1500Z	T3000Z	T1500A	Inscribed circle	Thickness	Nose Radius		
Cat. No.													
CCMT 09T304N-LUW		●	●	▲	●	●	●	●	●	●	9.525	3.97	0.4
09T308N-LUW		●	●	▲	●	●	●	●	●	●	9.525	3.97	0.8

### ● 7° Relief M-Class

CCMT LB		Stock						Dimensions (mm)					
		AC820P	AC830P	AC6030M	AC6040M	T1500Z	T3000Z	T1500A	Inscribed circle	Thickness	Nose Radius		
Cat. No.													
CCMT 060202N-LB		●	●	●	●	●	●	●	●	●	6.35	2.38	0.2
060204N-LB		●	●	●	●	●	●	●	●	●			0.4
060208N-LB		●	●	●	●	●	●	●	●	●			0.8
CCMT 09T302N-LB		●	●	●	●	●	●	●	●	●	9.525	3.97	0.2
09T304N-LB		●	●	●	●	●	●	●	●	●			0.4
09T308N-LB		●	●	●	●	●	●	●	●	●			0.8

CCMT FP		Stock				Dimensions (mm)			
		T1500A	T1200A				Inscribed circle	Thickness	Nose Radius
Cat. No.									
CCMT 060202N-FP		●	▲				6.35	2.38	0.2
060208N-FP		●	▲				9.525	3.97	0.8
CCMT 09T302N-FP		●	▲						0.2
09T304N-FP		●	▲						0.4
CCMT 120404N-FP		●	▲				12.7	4.76	0.4
120408N-FP		●	▲						0.8

CCMT SU		Stock											Dimensions (mm)						
		AC810P	AC820P	AC830P	AC2000	AC610M	AC630M	AC6030M	AC6040M	AC520U	AC530U	T1500Z	T3000Z	T1000A	T1500A	Inscribed circle	Thickness	Nose Radius	
Cat. No.																			
CCMT 060202N-SU		●	●	●	●	●	●	●	●	●	●	●	●	●	●	●	6.35	2.38	0.2
060204N-SU		●	●	●	●	●	●	●	●	●	●	●	●	●	●	●	9.525	3.97	0.4
060208N-SU		●	●	●	●	●	●	●	●	●	●	●	●	●	●	0.8			
CCMT 09T302N-SU		●	●	●	●	●	●	●	●	●	●	●	●	●	●	0.2			
09T304N-SU		●	●	●	●	●	●	●	●	●	●	●	●	●	●	0.4			
09T308N-SU		●	●	●	●	●	●	●	●	●	●	●	●	●	●	0.8			
CCMT 120404N-SU		●	●	●	▲											12.7	4.76	0.4	
120408N-SU		●	●	●	▲										0.8				

CCMT SC		Stock			Dimensions (mm)		
		AC820P	AC2000	A30	Inscribed circle	Thickness	Nose Radius
Cat. No.							
CCMT 060204N-SC		●	▲	●	6.35	2.38	0.4
120408N-SC		●	▲	●	12.7	4.76	0.8

CCMT MU		Stock								Dimensions (mm)				
		AC810P	AC820P	AC830P	AC2000	AC630M	AC405K	AC415K	AC420K	AC410K	Inscribed circle	Thickness	Nose Radius	
Cat. No.														
CCMT 09T304N-MU		●	●	▲	●	●	●	●	●	●	●	9.525	3.97	0.4
09T308N-MU		●	●	▲	●	●	●	●	●	●	●	9.525	3.97	0.8

CCMW —		Stock				Dimensions (mm)		
		AC405K	AC415K	AC420K	AC410K	Inscribed circle	Thickness	Nose Radius
Cat. No.								
CCMW 060204		●	●	●	▲	6.35	2.38	0.4
CCMW 09T304		●	●	●	▲	9.525	3.97	0.4
09T308		●	●	●	▲			0.8

▲ mark : To be replaced by new item (Please confirm stock availability)

# SEC-Boring Bars SCLC Type



■ Insert ( ■ SUMIBORON )

- 7° Relief E-Class
- SUMIBORON One-use Type
- (●: 1pc. per package stock, ●: 1pc. per package and 10pc. per package stock)

NU-CCEW		Stock				Dimensions (mm)		
		BNX20	BN7000	BN700	BN7500	Inscribed circle	Thickness	Nose Radius
Cat. No.								
NU-CCEW 03X102LF		●	●	●		3.5	1.4	0.2
03X104LF		—	—	—				0.4
03X102LT		—	—	—				0.2
03X104LT		—	—	—				0.4
NU-CCEW 04X102LF		—	●	●		4.3	1.8	0.2
04X104LF		—	—	—				0.4
04X102LT		●	—	—				0.2
04X104LT		●	—	—				0.4

\* LF: for sintered component and cast iron machining LT: for fine boring of hardened steel

- 7° Relief G-Class
- Coated SUMIBORON One-use Type/Multi corner

2NC-CCGW		Stock						Dimensions (mm)			
		BNC2010	BNC2020	BNC100	BNC160	BNC200	BNC300	BNC500	Inscribed circle	Thickness	Nose Radius
Cat. No.											
2NC-CCGW 060202		●	●						6.35	2.38	0.2
060204		●	●					0.4			
060208		—	—					0.8			
060202LS		—	—					0.2			
060204LS		—	—					0.4			
2NC-CCGW 09T302		●	●	●	●	●	●		9.525	3.97	0.2
09T304		●	●	●	●	●	●	0.4			
09T308		●	●	●	●	●	●	0.8			
09T304WG		●	●	—	—	—	—	0.4			
09T308WG		●	●	—	—	—	—	0.8			
09T304WH		●	●	—	—	—	—	0.4			
09T308WH		●	●	—	—	—	—	0.8			
09T302LS		—	—	●	●	●	●	0.2			
09T304LS		—	—	●	●	●	●	0.4			
09T308LS		—	—	●	●	●	●	0.8			
09T304HS		—	—	—	—	—	●	0.4			
09T308HS		—	—	—	—	—	●	0.8			

\*WG/WH: Wiper Insert LS: for fine boring of hardened steel HS: for Strong Edge Type

- Coated SUMIBORON Break Master

2NC-CCGT FV/LV		Stock				Dimensions (mm)		
		BNC2010	BNC2020	BNC160	BNC200	Inscribed circle	Thickness	Nose Radius
Cat. No.								
2NC-CCGT 060204N-FV		●	●			6.35	2.38	0.4
2NC-CCGT 09T304N-FV		●	●	●	●	9.525	3.97	0.4
09T308N-FV		●	●	●	●			0.8
09T304N-LV		●	●	●	●			0.4
09T308N-LV		●	●	●	●			0.8

- 7° Relief G-Class
- Uncoated SUMIBORON One-use Type/Multi corner

2NU-CCGW		Stock				Dimensions (mm)		
		BN2000	BN7000	BN7500				
Cat. No.								
2NU-CCGW 060204		●	●			6.35	2.38	0.4
2NU-CCGW 09T304		●	●					0.4
09T308		●	●			9.525	3.97	0.8
2NU-CCGW 09T304WG		●	—	—				0.4
09T308WG		●	—	—				0.8
09T304WH		●	—	—				0.4
09T308WH		●	—	—		0.8		

- Uncoated SUMIBORON One-use Type

(●: 1pc. per package stock, ●▲: 1pc. per package and 10pc. per package stock)

NU-CCGW		Stock					Dimensions (mm)		
		BN1000	BN2000	BN250	BN7000	BN700	Inscribed circle	Thickness	Nose Radius
Cat. No.									
NU-CCGW 060202		●	●	▲			6.35	2.38	0.2
060204		●	●	▲	●	●			0.4
060208		—	—	—	—	—			0.8
060202LT		—	—	—	—	—			0.2
060204LT		—	—	—	—	—			0.4
060208LT		—	—	—	—	—			0.8
060202LS		—	—	▲	—	—			0.2
060204LS		—	—	▲	—	—			0.4
060208LS		—	—	▲	—	—			0.8
060202HS		—	—	—	—	—			0.2
060204HS		—	—	—	—	—	0.4		
NU-CCGW 09T302		●	●	▲			9.525	3.97	0.2
09T304		●	●	▲	●	●			0.4
09T308		●	●	▲	—	—			0.8
09T304WG		●	●	—	—	—			0.4
09T308WG		●	●	—	—	—			0.8
09T304WH		●	●	—	—	—			0.4
09T308WH		●	●	—	—	—			0.8
09T302LS		—	—	—	—	—			0.2
09T304LS		—	—	—	—	—			0.4
09T308LS		—	—	—	—	—			0.8
09T302LS		—	—	▲	—	—			0.2
09T304LS		—	—	▲	—	—			0.4
09T308LS		—	—	▲	—	—			0.8
09T302HS		—	—	—	—	—	0.2		
09T304HS		—	—	—	—	—	0.4		
09T308HS		—	—	—	—	—	0.8		

\* LT: for fine boring of hardened steel LS: Continuous cutting HS: for Strong Edge Type

- Uncoated SUMIBORON Break Master

2NU-CCGT FV/LV		Stock				Dimensions (mm)		
		BN2000						
Cat. No.								
2NU-CCGT 060204N-FV		●				6.35	2.38	0.4
2NU-CCGT 09T304N-FV		●						0.4
09T308N-FV		●				9.525	3.97	0.8
09T304N-LV		●						0.4
09T308N-LV		●						0.8





# SEC-Boring Bars SCLC Type

■ Insert ( SUMIDIA)

- 7° Relief M-Class
- SUMIDIA NF Type

NF-CCMT		Stock				Dimensions (mm)		
		DA1000	DA2200			Inscribed circle	Thickness	Nose Radius
Cat. No.								
NF-CCMT 060201	● ▲							0.1
060202	● ▲				6.35	2.38		0.2
060204	● ▲							0.4
NF-CCMT 09T301	● ▲							0.1
09T302	● ▲				9.525	3.97		0.2
09T304	● ▲							0.4
09T308	● ▲							0.8

- SUMIDIA (Break Master)

NF-CCMT LD/GD		Stock				Dimensions (mm)		
		DA1000				Inscribed circle	Thickness	Nose Radius
Cat. No.								
NF-CCMT 060202N-LD	●							0.2
060204N-LD	●				6.35	2.38		0.4
060202N-GD	●							0.2
060204N-GD	●							0.4
NF-CCMT 09T302N-LD	●							0.2
09T304N-LD	●							0.4
09T308N-LD	●				9.525	3.97		0.8
09T302N-GD	●							0.2
09T304N-GD	●							0.4
09T308N-GD	●							0.8

\*LD: For Finishing, GD: For Medium Finishing

NU-CCMT DM		Stock				Dimensions (mm)		
		DA150				Inscribed circle	Thickness	Nose Radius
Cat. No.								
NU-CCMT 060202R-DM	●							0.2
060202L-DM	●				6.35	2.38		0.2
060204R-DM	●							0.4
060204L-DM	●							0.4
NU-CCMT 09T302R-DM	●							0.2
09T302L-DM	●				9.525	3.97		0.2
09T304R-DM	●							0.4
09T304L-DM	●							0.4

- SUMIDIA

CCMT		Stock				Dimensions (mm)		
		DA150	DA2200			Inscribed circle	Thickness	Nose Radius
Cat. No.								
CCMT 060201	● ▲							0.1
060202	● ▲				6.35	2.38		0.2
060204	● ▲							0.4
CCMT 09T301	● ▲							0.1
09T302	● ▲				9.525	3.97		0.2
09T304	● ▲							0.4

# SEC-Boring Bars S-SCLP/B-SCLP/D-SCLP Type

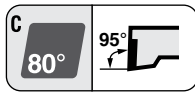

## Finish-Medium Cut

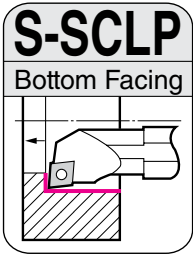

**Steel**

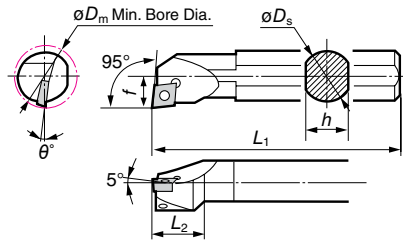

**Sumi Small**

**Holder** Right handed toolholders are applicable with left handed or neutral inserts.  
Left handed toolholders are applicable with right handed or neutral inserts.

Above figures show right hand tools.

**■ Spare Parts**

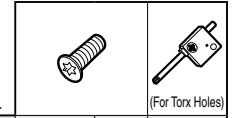

Shank	Cat. No.	Conventional Cat. No.	Stock		Dimensions (mm)							Applicable Insert	Screw	Recommended Tightening Torque (N·m)	Wrench	
			R	L	$\phi D_m$	$\phi D_s$	$h$	$L_1$	$f$	$L_2$	$\theta^\circ$					
Steel	<b>S10K-SCLP R/L0802-12</b>	BBPC-010 R/L	●	●	12	10	9	125	6.0	12.0	-5	CP □□0802□□	BFTX0305A	2.0	TRX10	
	<b>S12M-SCLP R/L0802-14</b>	BBPC-012 R/L14	●	●	14	12	11	150	7.0	10.6	-5					
	<b>S12M-SCLP R/L0802-16</b>	BBPC-012 R/L	▲	▲	16	12	11	150	8.0	15.0	-3					
	<b>S12M-SCLP R/L0903-16</b>	—	—	●	●	16	12	11	150	8.0	23.0	-6	CP □□0903□□	BFTX0407A	3.4	TRX15
	<b>S16R-SCLP R/L0903-18</b>	BBPC-316 R/L18	●	●	18	16	15	200	9.0	18.0	-4					
	<b>S16R-SCLP R/L0903-20</b>	BBPC-316 R/L	▲	▲	20	16	15	200	10.0	18.0	-3					
	<b>S20S-SCLP R/L0903-22</b>	BBPC-320 R/L22	●	●	22	20	18	250	11.0	18.0	-2					
	<b>S20S-SCLP R/L0903-25</b>	BBPC-320 R/L	▲	▲	25	20	18	250	12.5	18.0	0					
	<b>S25T-SCLP R/L0903-27</b>	—	—	●	●	27	25	22	300	13.5	18.0	-2				
	<b>S25T-SCLP R/L0903-28</b>	BBPC-325 R/L	▲	▲	28	25	22	300	14.0	35.0	-2					
<b>S25T-SCLP R/L1204-28</b>	BBPC-425 R/L	▲	▲	28	25	22	300	14.0	17.4	-2	CP □□1204□□	BFTX0509A	5.0	TRX20		

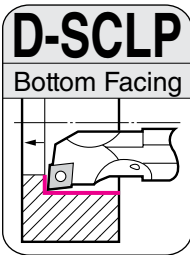
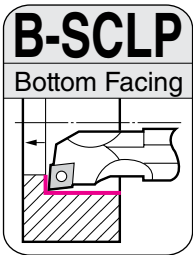

**Anti-vibration**

**Anti-vibration with oil hole**

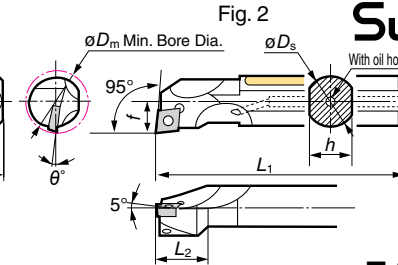
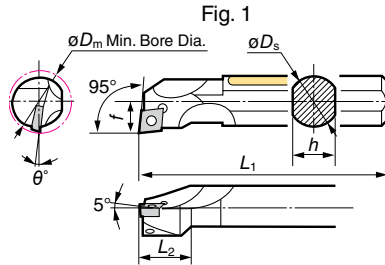

**SumiTurn** **Bar**

**Sumi Small**

**Holder** Right handed toolholders are applicable with left handed or neutral inserts.  
Left handed toolholders are applicable with right handed or neutral inserts.

Above figures show right hand tools.

**■ Spare Parts**

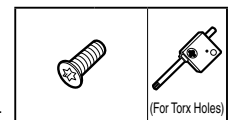

Shank	Cat. No.	Conventional Cat. No.	Stock		Dimensions (mm)							Fig.	Applicable Insert	Screw	Recommended Tightening Torque (N·m)	Wrench
			R	L	$\phi D_m$	$\phi D_s$	$h$	$L_1$	$f$	$L_2$	$\theta^\circ$					
Anti-vibration	<b>B12M-SCLP R/L0802-14</b>	XBPC-012 R/L14	●	●	14	12	11	150	7	10.6	-5	1	CP □□0802□□	BFTX0305A	2.0	TRX10
	<b>B16R-SCLP R/L0903-18</b>	XBPC-316 R/L18	●	●	18	16	15	200	9	18.0	-4	1	CP □□0903□□	BFTX0407A	3.4	TRX15
	<b>B20S-SCLP R/L0903-22</b>	XBPC-320 R/L22	●	●	22	20	18	250	11	18.0	-2					
Anti-vibration with oil hole	<b>D12M-SCLP R/L0802-14</b>	XBPC-012 R/L H14	●	●	14	12	11	150	7	10.6	-5	2	CP □□0802□□	BFTX0305A	2.0	TRX10
	<b>D16R-SCLP R/L0903-18</b>	XBPC-316 R/L H18	●	●	18	16	15	200	9	18.0	-4	2	CP □□0903□□	BFTX0407A	3.4	TRX15
	<b>D20S-SCLP R/L0903-22</b>	XBPC-320 R/L H22	●	●	22	20	18	250	11	18.0	-2					

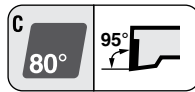

# SEC-Boring Bars C-SCLP Type

**Finish-Medium Cut**

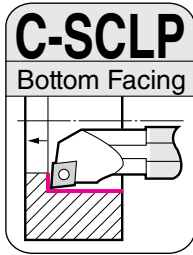

**Carbide**

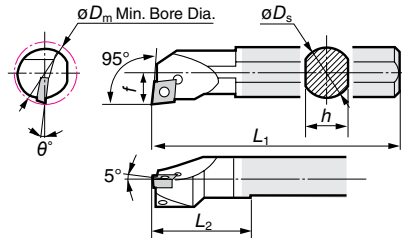

**Sumi Small**

■ Spare Parts

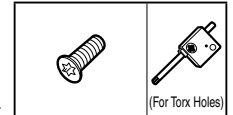

■ Holder Right handed toolholders are applicable with left handed or neutral inserts.  
Left handed toolholders are applicable with right handed or neutral inserts.

Above figures show right hand tools.

Shank	Cat. No.	Conventional Cat. No.	Stock		Dimensions (mm)							Applicable Insert	Screw	Recommended Tightening Torque (N·m)	Wrench
			R	L	$\phi D_m$	$\phi D_s$	h	$L_1$	f	$L_2$	$\theta^\circ$				
Carbide	<b>C10K-SCLP R/L0802-12</b>	WBPC-010 R/L S	●	●	12	10	9	125	6	19	-5	CP □□0802□□	BFTX0305A	2.0	TRX10
	<b>C12M-SCLP R/L0802-14</b>	WBPC-012 R/L S14	●	●	14	12	11	150	7	25	-5				
	<b>C12M-SCLP R/L0802-16</b>	WBPC-012 R/L S	●	●	16	12	11	150	8	25	-3				
	<b>C16R-SCLP R/L0903-18</b>	WBPC-316 R/L S18	●	●	18	16	15	200	9	30	-4	CP □□0903□□	BFTX0407A	3.4	TRX15
	<b>C16R-SCLP R/L0903-20</b>	WBPC-316 R/L S	●	●	20	16	15	200	10	30	-3				

■ Insert ( Coated / Cermet / Carbide)

● 11° Relief G-Class

CPGT SD	Cat. No.	Stock						Dimensions (mm)					
		AC510U	T1500Z	T3000Z	T2000Z	T1000A	T1500A	T110A	T1200A	G10E	Inscribed circle	Thickness	Nose Radius
CPGT 080202N-SD		●											0.2
CPGT 080204N-SD		●								7.94	2.38	0.4	
CPGT 080208N-SD		●										0.8	
CPGT 090302N-SD		●										0.2	
CPGT 090304N-SD		●								9.525	3.18	0.4	
CPGT 090308N-SD		●										0.8	
CPGT 120402N-SD		●										0.2	
CPGT 120404N-SD		●								12.70	4.76	0.4	
CPGT 120408N-SD		●										0.8	

● 11° Relief M-Class

CPMT LB	Cat. No.	Stock						Dimensions (mm)				
		AC820P	AC830P	AC6030M	AC6040M	T1500Z	T3000Z	T1500A	Inscribed circle	Thickness	Nose Radius	
CPMT 090304N-LB		●	●	●	●	●	●	●	●	9.525	3.18	0.4
CPMT 090308N-LB		●	●	●	●	●	●	●	●			0.8

● 11° Relief M-Class

CPMT FB	Cat. No.	Stock				Dimensions (mm)			
		AC530U	T1500Z	T3000Z	T1000A	T1500A	Inscribed circle	Thickness	Nose Radius
CPMT 080204N-FB		●	●	●	●	●	7.94	2.38	0.4
CPMT 090304N-FB		●	●	●	●	●	9.525	3.18	0.4
CPMT 090308N-FB		●	●	●	●	●			0.8

CPMT SU	Cat. No.	Stock						Dimensions (mm)				
		AC810P	AC820P	AC830P	AC610M	AC630M	T1500Z	T3000Z	T1000A	T1500A	Inscribed circle	Thickness
CPMT 080204N-SU		●	●	●	●	●	●	●	●	7.94	2.38	0.4
CPMT 080208N-SU		●	●	●	●	●	●	●	●			0.8
CPMT 090304N-SU		●	●	●	●	●	●	●	●	9.525	3.18	0.4
CPMT 090308N-SU		●	●	●	●	●	●	●	●			0.8

CPMT LU	Cat. No.	Stock						Dimensions (mm)				
		AC810P	AC820P	AC2000	AC630M	T1500Z	T3000Z	T1000A	T1500A	T1200A	Inscribed circle	Thickness
CPMT 080204N-LU		●	●	●	●	●	●	●	●	7.94	2.38	0.4
CPMT 090304N-LU		●	●	●	●	●	●	●	●	9.525	3.18	0.4
CPMT 090308N-LU		●	●	●	●	●	●	●	●			0.8

CPMT MU	Cat. No.	Stock						Dimensions (mm)				
		AC810P	AC820P	AC2000	AC630M	AC405K	AC415K	AC420K	AC410K	Inscribed circle	Thickness	Nose Radius
CPMT 080204N-MU		●	●	●	●	●	●	●	●	7.94	2.38	0.4
CPMT 080208N-MU		●	●	●	●	●	●	●	●			0.8
CPMT 090304N-MU		●	●	●	●	●	●	●	●	9.525	3.18	0.4
CPMT 090308N-MU		●	●	●	●	●	●	●	●			0.8

CPMT LUW	Cat. No.	Stock						Dimensions (mm)				
		AC810P	AC820P	AC2000	AC630M	T1500Z	T3000Z	T1500A	Inscribed circle	Thickness	Nose Radius	
CPMT 090304N-LUW		●	●	●	●	●	●	●	●	9.525	3.18	0.4
CPMT 090308N-LUW		●	●	●	●	●	●	●	●			0.8

CPMW I	Cat. No.	Stock				Dimensions (mm)		
		AC405K	AC415K	AC420K	AC410K	Inscribed circle	Thickness	Nose Radius
CPMW 080204		●	●	●	●	7.94	2.38	0.4
CPMW 080208		●	●	●	●			0.8
CPMW 090304		●	●	●	●	9.525	3.18	0.4
CPMW 090308		●	●	●	●			0.8

▲ mark : To be replaced by new item (Please confirm stock availability)

# SEC-Boring Bars SCLP Type



■ Insert ( SUMIBORON / SUMIDIA)

- 11° Relief G-Class
- SUMIBORON One-use Type

NU-CPGW		Stock			Dimensions (mm)				
		BN1000	BN2000	BN250	Inscribed circle	Thickness	Nose Radius		
Cat. No.									
NU-CPGW 080202		●	●	▲	7.94	2.38	0.2		
080204		●	●	▲			0.4		
080208		●	●	▲			0.8		
080204LT		—	●	—			0.4		
080202LS		—	—	▲			0.2		
080204LS		—	—	▲			0.4		
080208LS		—	—	▲			0.8		
080202HS		—	●	—			0.2		
080204HS		—	●	—			0.4		
080208HS		—	●	—			0.8		
NU-CPGW 090302		●	●	▲			9.525	3.18	0.2
090304		●	●	▲					0.4
090308		●	●	▲					0.8
090302LT		—	●	—					0.2
090304LT		—	●	—	0.4				
090308LT		—	●	—	0.8				
090302LS		—	—	▲	0.2				
090304LS		—	—	▲	0.4				
090308LS		—	—	▲	0.8				
090302HS		—	●	—	0.2				
090304HS		—	●	—	0.4				
090308HS		—	●	—	0.8				

\* LT: for fine boring of hardened steel LS: Continuous cutting HS: for Strong Edge Type

- 11° Relief M-Class
- SUMIDIA NF Type

NF-CPMT		Stock		Dimensions (mm)		
		DA1000	DA2200	Inscribed circle	Thickness	Nose Radius
Cat. No.						
NF-CPMT 090302		●	▲	9.525	3.18	0.2
090304		●	▲			0.4
090308		●	▲			0.8

- SUMIDIA

CPMT		Stock			Dimensions (mm)		
		DA1000	DA2200	Inscribed circle	Thickness	Nose Radius	
Cat. No.							
CPMT 080202		●	▲	7.94	2.38	0.2	
080204		●	▲			0.4	
080208		●	▲			0.8	
CPMT 090302		—	▲	9.525	3.18	0.2	
090304		—	▲			0.4	
090308		—	▲			0.8	

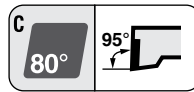

# SEC-Boring Bars S-DCLN/D-DCLN Type

## General Boring

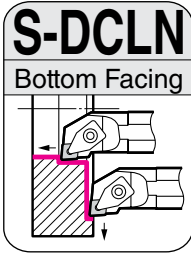

Steel

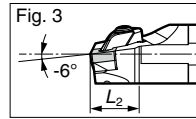
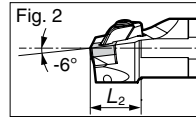
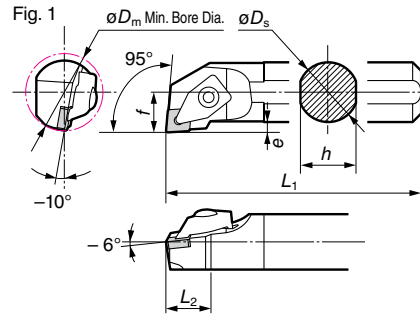

### Insert

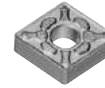

· CNMG090308N-GU  
(Representative example)

### Spare Parts

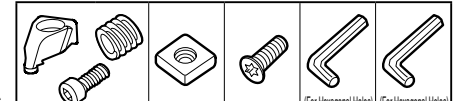

### Holder

Direction of applicable inserts differs according to work material (\*Refer to note at bottom of page E45) Above figures show right hand tools.

Shank	Cat. No.	Conventional Cat. No.	Stock		Dimensions (mm)							Fig.	Applicable Insert Cat. No.	Featured page	Clamp Set	Recommended Tightening Torque (N·m)	Shim	Shim Screw	Wrench for Upper Surface	Wrench for Lower Surface
			R	L	$\phi D_m$	$\phi D_s$	$h$	$L_1$	$f$	$L_2$	$e$									
Steel	S25R-DCLN R/L0903-32	—	●	●	32	25	23	200	17.0	18	4.5	1	CN □□0903□□	B20	SCP-1	5.0	—	—	LH040	LH025
	S25T-DCLN R/L0903-32	S25T-DCLN R/L09	●	●	32	25	23	300	17.0	18	4.5	1	CN □□0903□□	B20	SCP-1	5.0	—	—	LH040	LH025
	S32S-DCLN R/L1204-40	—	●	●	40	32	30	250	22.0	26	7.0	2	CN □□1204□□	From B21	SCP-2	5.0	CNS1204B	BFTX0409N	LH040	LH025
	S40T-DCLN R/L1204-50	—	●	●	50	40	37	300	27.0	26	8.5	2	CN □□1204□□	From B21	SCP-2	5.0	CNS1204B	BFTX0409N	LH040	LH025
	S50U-DCLN R/L1204-63	—	●	●	63	50	47	350	31.5	36	8.0	3	CN □□1204□□	From B21	SCP-2	5.0	CNS1204B	BFTX0409N	LH040	LH025

Clamp Set Parts E77

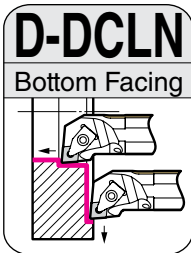

Anti-vibration with oil hole

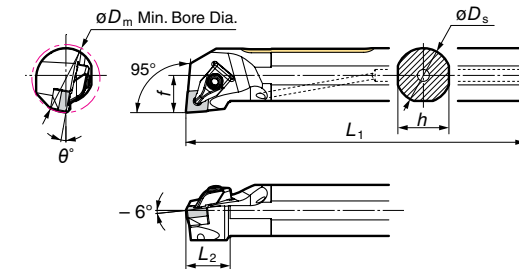

### Insert



· CNMG120408N-GE  
(Representative example)

### Spare Parts

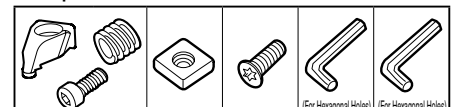

### Holder

Right handed toolholders are applicable with left handed or neutral inserts. Left handed toolholders are applicable with right handed or neutral inserts. Above figures show right hand tools.

Shank	Cat. No.	Stock		Dimensions (mm)							Fig.	Applicable Insert Cat. No.	Featured page	Clamp Set	Recommended Tightening Torque (N·m)	Shim	Shim Screw	Wrench for Upper Surface	Wrench for Lower Surface
		R	L	$\phi D_m$	$\phi D_s$	$h$	$L_1$	$f$	$L_2$	$\theta$									
Anti-vibration with oil hole	D25T-DCLN R/L1204-32	●	●	32	25	23	300	17	26	-12	1	CN □□1204□□	From B21	SCP-2	5.0	CNS1203B	BFTX0307N	LH040	LH025
	D32T-DCLN R/L1204-40	●	●	40	32	30	300	22	26	-10	1	CN □□1204□□	From B21	SCP-2	5.0	CNS1203B	BFTX0307N	LH040	LH025
	D40U-DCLN R/L1204-50	●	●	50	40	37	350	27	26	-10	1	CN □□1204□□	From B21	SCP-2	5.0	CNS1204B	BFTX0409N	LH040	LH025

Clamp Set Parts E77

### \* Applicable Inserts for DCLN and PCLN Types

When machining internal diameters: Right handed toolholders are applicable with left handed or neutral inserts. Left handed toolholders are applicable with right handed or neutral inserts.  
When face grooving: Right handed toolholders are applicable with right handed or neutral inserts. Left handed toolholders are applicable with left handed or neutral inserts.

E Boring Bars

# SEC-Boring Bars S-PCLN/B-PCLN Type

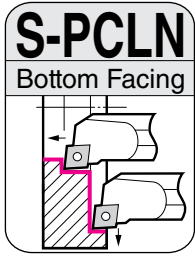
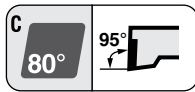

Steel

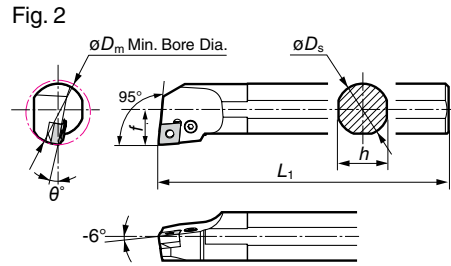
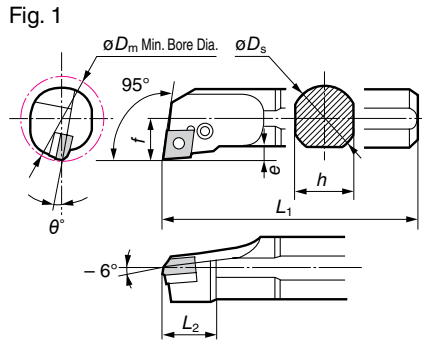

### ■ Spare Parts

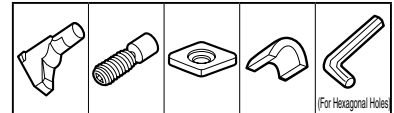

### ■ Holder

Direction of applicable inserts differs according to work material (\*Refer to note at bottom of page E46) Above figures show right hand tools.

Shank	Cat. No.	Conventional Cat. No.	Stock		Dimensions (mm)							Fig.	Applicable Insert Cat. No.	Featured page	Lever Pin	Clamp Bolt	Shim	Shim Pin	Wrench	
			R	L	$\phi D_m$	$\phi D_s$	$h$	$L_1$	$f$	$L_2$	$e$									$\theta^\circ$
Steel	S25R-PCLN R/L0903-32	—	●	●	32	25	23	200	17.0	30	4.5	-15	1	CN□□0903□□	B20	LCL3	LCS3	LSC32	LSP3	LH025
	S32S-PCLN R/L1204-40	—	●	●	40	32	30	250	22.0	29	7.0	-10	1	CN□□1204□□	From B21	LCL4	LCS4	LSC42B	LSP4	LH030
	S32S-PCLN R/L1204-44	S32S-PCLN R/L12	●	●	44	32	30	250	22.0	29	7.0	-10						LSC42		
	S40T-PCLN R/L1204-50	—	●	●	50	40	37	300	25.0	29	6.5	-10	2	CN□□1906□□	From B26	LCL6	LCS6	LSC42B	LSP6	LH040
	S40T-PCLN R/L1204-54	S40T-PCLN R/L12	●	●	54	40	37	300	27.0	29	8.5	-10						LSC42B		
	S50U-PCLN R/L1204-63	—	●	●	63	50	47	350	31.5	—	8.0	-10	1	CN□□1906□□	From B26	LCL6	LCS6	LSC63	LSP6	LH040
S50U-PCLN R/L1906-70	S50U-PCLN R/L19	●	●	70	50	47	350	35.0	39	11.5	-10	LSC63								

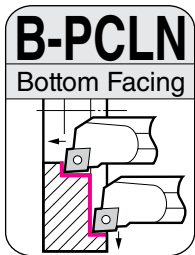

Anti-vibration

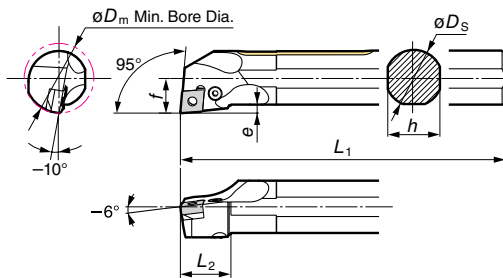

### ■ Insert

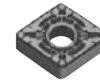

· CNMG120408N-GE  
(Representative example)

### ■ Spare Parts

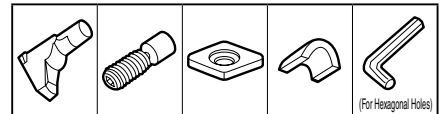

### ■ Holder

Direction of applicable inserts differs according to work material (\*Refer to note at bottom of page E46) Above figures show right hand tools.

Shank	Cat. No.	Stock		Dimensions (mm)							Applicable Insert		Lever Pin	Clamp Bolt	Shim	Shim Pin	Wrench
		R	L	$\phi D_m$	$\phi D_s$	$h$	$L_1$	$f$	$L_2$	$e$	Cat. No.	Featured page					
Anti-vibration	B32U-PCLN R/L1204-40	●	●	40	32	30	350	20	29	5.0	CN□□1204□□	From B21	LCL4	LCS4CA LCS4	LSC42B	LSP4	LH030
	B40W-PCLN R/L1204-50	●	●	50	40	37	450	25	29	6.5							

### \* Applicable Inserts for PCLN Types

When machining internal diameters: Right handed toolholders are applicable with left handed or neutral inserts. Left handed toolholders are applicable with right handed or neutral inserts.  
When face grooving: Right handed toolholders are applicable with right handed or neutral inserts. Left handed toolholders are applicable with left handed or neutral inserts.

# SEC-Boring Bars S-ECLN/D-DWLN Type

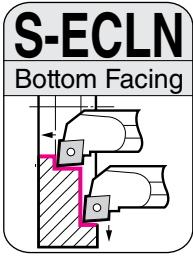
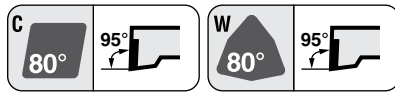

Steel

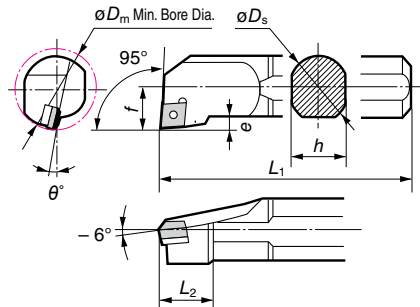

### Insert

UX Type

- CNMG090308N-UX
- CNMG120408N-GE
- CNMG190612N-UX (Representative example)

GE Type

### Spare Parts

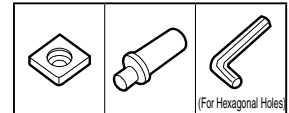

■ Holder Direction of applicable inserts differs according to work material (\*Refer to note at bottom of page E47) Above figures show right hand tools.

Shank	Cat. No.	Conventional Cat. No.	Stock		Dimensions (mm)								Applicable Insert		Shim	Pin	Wrench
			R	L	$\theta D_m$	$\theta D_s$	$h$	$L_1$	$f$	$L_2$	$e$	$\theta^\circ$	Cat. No.	Featured page			
Steel	S20Q-ECLN R/L0903-26	BCLN320 R/L	●	●	26	20	18	180	13	20	4.0	-12	CN □□0903□□	B20	—	CPU304C	LH030
	S25R-ECLN R/L0903-34	BCLN325 R/L	●	●	34	25	23	200	17	20	5.5	-12			SCW323	CPB32C	LH025
	S25R-ECLN R/L1204-34	BCLN425 R/L	●	●	34	25	23	200	17	20	5.5	-12	CN □□1204□□	From B21	—	CPB42	LH030
	S32S-ECLN R/L1204-44	BCLN432 R/L	●	●	44	32	30	250	22	25	7.0	-10			SCW423	CPB43S	LH030
	S40T-ECLN R/L1204-54	BCLN440 R/L	●	●	54	40	37	300	27	25	8.5	-10	CN □□1906□□	From B26	—	CPB43	LH040
	S50U-ECLN R/L1906-70	BCLN650 R/L	●	●	70	50	47	350	35	32	11.5	-10			SCW635	CPB64	LH040

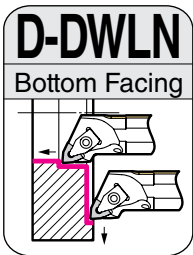

Anti-vibration with oil hole

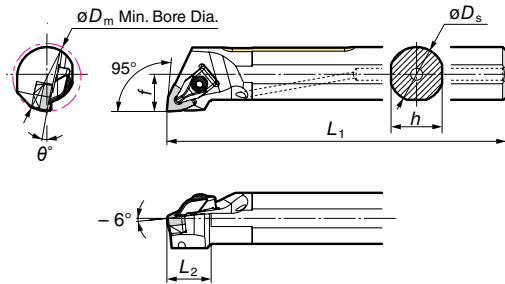

### Insert

SumiTura Bar

- WNMG080408N-GE (Representative example)

### Spare Parts

Clamp Set	Recommended Tightening Torque (N·m)	Shim	Shim Screw	Wrench for Upper Surface	Wrench for Lower Surface
SCP-2	5.0	WNS0803B	BFTX0307N	LH040	LH025
		WNS0804B	BFTX0409N		

■ Holder Direction of applicable inserts differs according to work material (\*Refer to note at bottom of page E47) Above figures show right hand tools.

Shank	Cat. No.	Stock		Dimensions (mm)								Applicable Insert		Clamp Set	Recommended Tightening Torque (N·m)	Shim	Shim Screw	Wrench for Upper Surface	Wrench for Lower Surface
		R	L	$\theta D_m$	$\theta D_s$	$h$	$L_1$	$f$	$L_2$	$\theta^\circ$	Cat. No.	Featured page							
Anti-vibration with oil hole	D25T-DWLN R/L0804-32	●	●	32	25	23	300	17	26	-12	WN □□0804□□	From B68	SCP-2	5.0	WNS0803B	BFTX0307N	LH040	LH025	
	D32T-DWLN R/L0804-40	●	●	40	32	30	300	22	26	-10					WNS0804B	BFTX0409N			
	D40U-DWLN R/L0804-50	●	●	50	40	37	350	27	26	-10									

Clamp Set Parts

### \* Applicable Inserts for ECLN and DWLN Types

When machining internal diameters: Right handed toolholders are applicable with left handed or neutral inserts. Left handed toolholders are applicable with right handed or neutral inserts.  
When face grooving: Right handed toolholders are applicable with right handed or neutral inserts. Left handed toolholders are applicable with left handed or neutral inserts.

E Boring Bars

# SEC-Boring Bars S-DWLN/S-PWLN Type

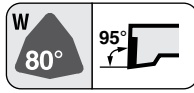

## General Boring

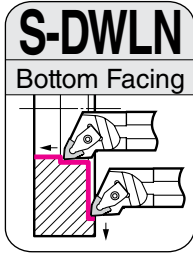

Steel

New

Fig. 1

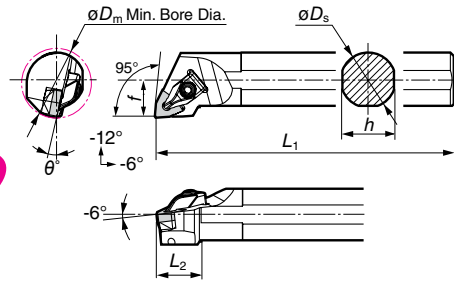
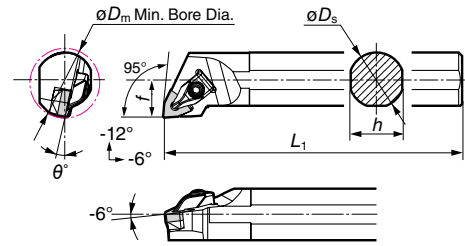
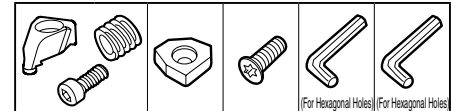

Fig. 2



### Spare Parts



### Holder

Direction of applicable inserts differs according to work material (\*Refer to note at bottom of page E48) Above figures show right hand tools.

Shank	Cat. No.	Stock		Dimensions (mm)							Fig.	Applicable Insert		Clamp Set	Recommended Tightening Torque (N·m)	Shim	Shim Screw	Wrench for Upper Surface	Wrench for Lower Surface
		R	L	$\phi D_m$	$\phi D_s$	$h$	$L_1$	$f$	$L_2$	$\theta^\circ$		Cat. No.	Featured page						
Steel	S32S-DWLN R/L0604-40			40	32	30	250	22.0	29	-10	1	WN □□0604□□	B67	SCP-4	5.0	WNS0603B	BFTX0307N	LH040	LH025
	S25R-DWLN R/L0804-32			32	25	23	200	17.0	26	-12									
	S32S-DWLN R/L0804-40			40	32	30	250	22.0	26	-12	1	WN □□0804□□	From B68	SCP-2	5.0	WNS0803B	BFTX0307N	LH040	LH025
	S40T-DWLN R/L0804-50			50	40	37	300	27.0	26	-12									
	S50U-DWLN R/L0804-63			63	50	47	350	31.5	—	-12	2								

Clamp Set Parts

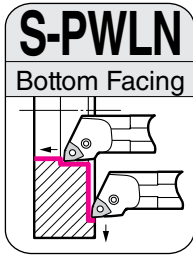

Steel

New

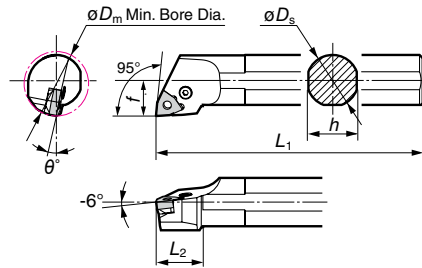

### Insert



### Spare Parts

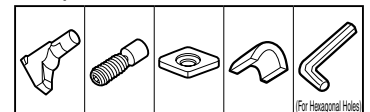

### Holder

Right handed toolholders are applicable with **right handed** or neutral inserts.  
Left handed toolholders are applicable with **left handed** or neutral inserts. Above figures show right hand tools.

Shank	Cat. No.	Stock		Dimensions (mm)							Fig.	Applicable Insert		Lever Pin	Clamp Bolt	Shim	Shim Pin	Wrench
		R	L	$\phi D_m$	$\phi D_s$	$h$	$L_1$	$f$	$L_2$	$\theta^\circ$		Cat. No.	Featured page					
Steel	S32S-PWLN R/L0604-40			40	32	30	250	22	29	-10	1	WN □□0604□□	B67	LCL3	LCS3	LSW317	LSP3	LH025
	S32S-PWLN R/L0804-40			40	32	30	250	22	29	-10								
	S40T-PWLN R/L0804-50			50	40	37	300	27	29	-10		WN □□0804□□	From B68	LCL4	LCS4	LSW42B	LSP4	LH030

### \* Applicable Inserts for DWLN and PWLN Types

When machining internal diameters: Right handed toolholders are applicable with **left handed** or **neutral** inserts. Left handed toolholders are applicable with **right handed** or **neutral** inserts.  
When face grooving: Right handed toolholders are applicable with **right handed** or **neutral** inserts. Left handed toolholders are applicable with **left handed** or **neutral** inserts.





# SEC-Boring Bars S-SDUC/B-SDUC/C-SDUC Type

## Internal Copying

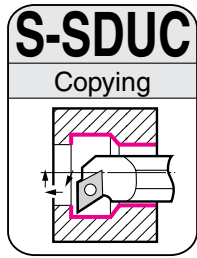

Steel

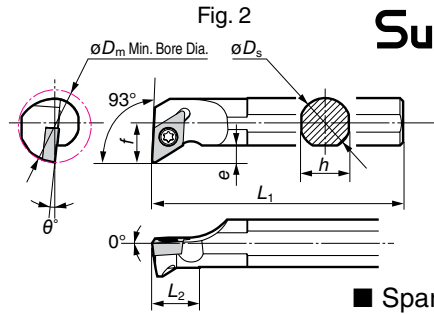
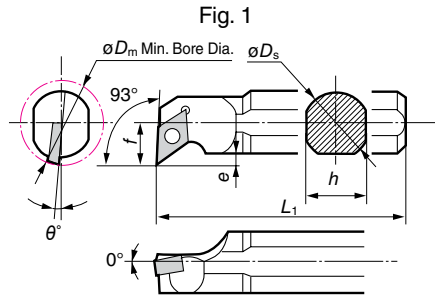

Sumi Small

### ■ Spare Parts

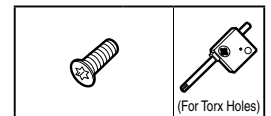

■ Holder Right handed toolholders are applicable with left handed or neutral inserts.  
Left handed toolholders are applicable with right handed or neutral inserts.

Above figures show right hand tools.

Shank	Cat. No.	Conventional Cat. No.	Stock		Dimensions (mm)							Fig.	Applicable Insert	Screw	Recommended Tightening Torque (N·m)	Wrench	
			R	L	$\phi D_m$	$\phi D_s$	$h$	$L_1$	$f$	$e$	$\theta^\circ$						$L_2$
Steel	S10M-SDUC R/L0702-13	S10M-SDUC R/L07	●	●	13	10	9	150	7.0	2.5	-8	—	1	DC □□0702□□	BFTX02506N	1.5	TRX08
	S12M-SDUC R/L0702-16	S12M-SDUC R/L07	●	●	16	12	11	150	9.0	3.5	-8	—					
	S16Q-SDUC R/L0702-20	—	●	●	20	16	15	180	11.0	4.0	-6	—					
	S16N-SDUC R/L0702-20	S16N-SDUC R/L07	●	●	20	16	15	160	11.0	4.0	-6	—					
	S16Q-SDUC R/L11T3-23	—	●	●	23	16	15	180	12.5	5.5	-6	15	2	DC □□11T3□□	BFTX0409N	3.4	TRX15
	S20R-SDUC R/L11T3-25	—	●	●	25	20	18	200	13.0	4.5	-6	—					
	S20N-SDUC R/L11T3-25	S20N-SDUC R/L11	●	●	25	20	18	160	13.0	4.5	-6	—	1	DC □□11T3□□	BFTX0409N	3.4	TRX15
	S25S-SDUC R/L11T3-32	—	●	●	32	25	22	250	17.0	7.0	-6	—					
	S25Q-SDUC R/L11T3-32	S25Q-SDUC R/L11	●	●	32	25	22	180	17.0	7.0	-6	—					

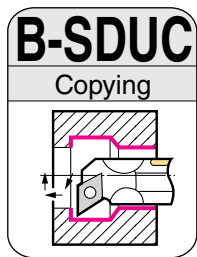

Anti-vibration

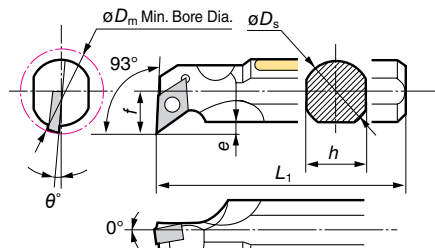

SumiTurn *Bar*

Sumi Small

### ■ Spare Parts

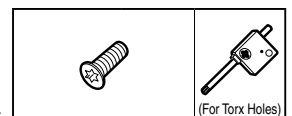

■ Holder Right handed toolholders are applicable with left handed or neutral inserts.  
Left handed toolholders are applicable with right handed or neutral inserts.

Above figures show right hand tools.

Shank	Cat. No.	Stock		Dimensions (mm)							Applicable Insert	Screw	Recommended Tightening Torque (N·m)	Wrench
		R	L	$\phi D_m$	$\phi D_s$	$h$	$L_1$	$f$	$e$	$\theta^\circ$				
Anti-vibration	B10M-SDUC R/L0702-13	●	●	13	10	9	150	7	2.5	-8	DC □□0702□□	BFTX02506N	1.5	TRX08
	B12M-SDUC R/L0702-16	●	●	16	12	11	150	9	3.5	-8				
	B16R-SDUC R/L0702-20	●	●	20	16	15	200	11	4.0	-6	DC □□11T3□□	BFTX0409N	3.4	TRX15
	B20S-SDUC R/L11T3-25	●	●	25	20	18	250	13	4.5	-6				
	B25S-SDUC R/L11T3-32	●	●	32	25	22	250	17	7.0	-6				

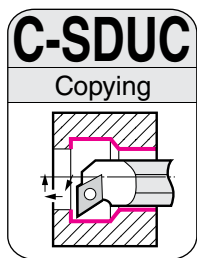

Carbide

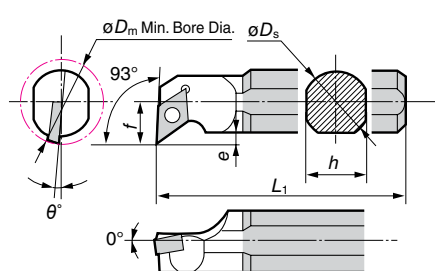

Sumi Small

### ■ Spare Parts

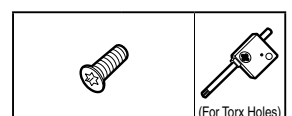

■ Holder Right handed toolholders are applicable with left handed or neutral inserts.  
Left handed toolholders are applicable with right handed or neutral inserts.

Above figures show right hand tools.

Shank	Cat. No.	Stock		Dimensions (mm)							Applicable Insert	Screw	Recommended Tightening Torque (N·m)	Wrench
		R	L	$\phi D_m$	$\phi D_s$	$h$	$L_1$	$f$	$e$	$\theta^\circ$				
Carbide	C10M-SDUC R/L0702-13	●	●	13	10	9	150	7	2.5	-8	DC □□0702□□	BFTX02506N	1.5	TRX08
	C12M-SDUC R/L0702-16	●	●	16	12	11	150	9	3.5	-8				
	C16R-SDUC R/L0702-20	●	●	20	16	15	200	11	4.0	-6	DC □□11T3□□	BFTX0409N	3.4	TRX15
	C20S-SDUC R/L11T3-25	●	●	25	20	18	250	13	4.5	-6				

E Boring Bars

# SEC-Boring Bars S-SDQC/B-SDQC Type

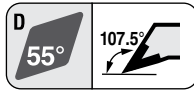

## Internal Copying

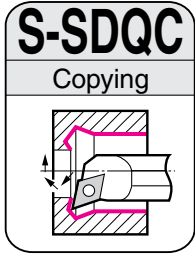

**Steel**

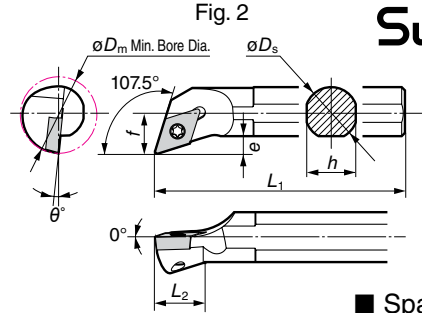
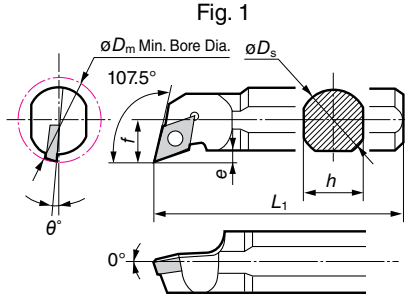

**SumiSmall**

### Spare Parts

**Holder** Right handed toolholders are applicable with left handed or neutral inserts.  
Left handed toolholders are applicable with right handed or neutral inserts.

Above figures show right hand tools.

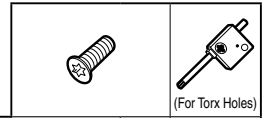

Shank	Cat. No.	Conventional Cat. No.	Stock		Dimensions (mm)							Fig.	Applicable Insert	Screw	Recommended Tightening Torque (N·m)	Wrench	
			R	L	$\phi D_m$	$\phi D_s$	$h$	$L_1$	$f$	$e$	$\theta^\circ$						$L_2$
Steel	S10M-SDQC R/L0702-13	S10M-SDQC R/L07	●	●	13	10	9	150	7.0	2.5	-8	—	1	DC □□0702□□	BFTX02506N	1.5	TRX08
	S12M-SDQC R/L0702-16	S12M-SDQC R/L07	●	●	16	12	11	150	9.0	3.5	-8	—					
	S16Q-SDQC R/L0702-20	—	●	●	20	16	15	180	11.0	4.0	-6	—					
	S16N-SDQC R/L0702-20	S16N-SDQC R/L07	●	●	20	16	15	160	11.0	4.0	-6	—					
	S16Q-SDQC R/L11T3-23	—	●	●	23	16	15	180	12.5	5.5	-6	15	2	DC □□11T3□□	BFTX0409N	3.4	TRX15
	S20R-SDQC R/L11T3-25	—	●	●	25	20	18	200	13.0	4.5	-6	—					
	S20N-SDQC R/L11T3-25	S20N-SDQC R/L11	●	●	25	20	18	160	13.0	4.5	-6	—					
	S25S-SDQC R/L11T3-32	—	●	●	32	25	22	250	17.0	7.0	-6	—					
S25Q-SDQC R/L11T3-32	S25Q-SDQC R/L11	●	●	32	25	22	180	17.0	7.0	-6	—	1					

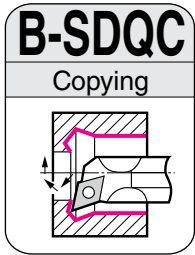

**Anti-vibration**

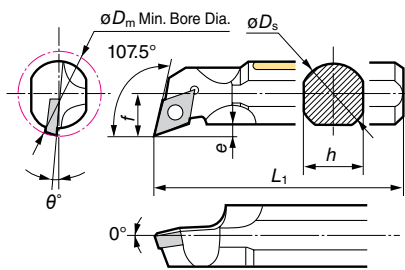

**SumiTurn** *Bar*

**SumiSmall**

### Spare Parts

**Holder** Right handed toolholders are applicable with left handed or neutral inserts.  
Left handed toolholders are applicable with right handed or neutral inserts.

Above figures show right hand tools.

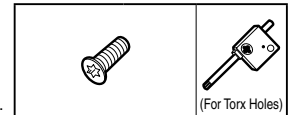

Shank	Cat. No.	Stock		Dimensions (mm)							Applicable Insert	Screw	Recommended Tightening Torque (N·m)	Wrench
		R	L	$\phi D_m$	$\phi D_s$	$h$	$L_1$	$f$	$e$	$\theta^\circ$				
Anti-vibration	B10M-SDQC R/L0702-13	●	●	13	10	9	150	7	2.5	-8	DC □□0702□□	BFTX02506N	1.5	TRX08
	B12M-SDQC R/L0702-16	●	●	16	12	11	150	9	3.5	-8				
	B16R-SDQC R/L0702-20	●	●	20	16	15	200	11	4.0	-6				
	B20S-SDQC R/L11T3-25	●	●	25	20	18	250	13	4.5	-6	DC □□11T3□□	BFTX0409N	3.4	TRX15
	B25S-SDQC R/L11T3-32	●	●	32	25	22	250	17	7.0	-6				

# SEC-Boring Bars S-SDZC Type



## Internal Copying

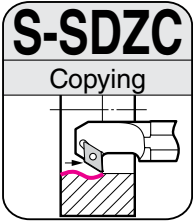

Steel

New

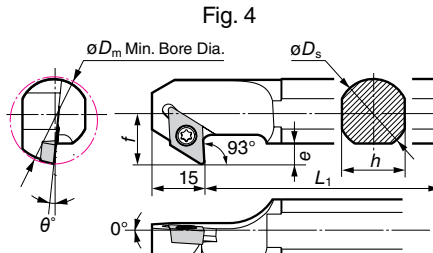
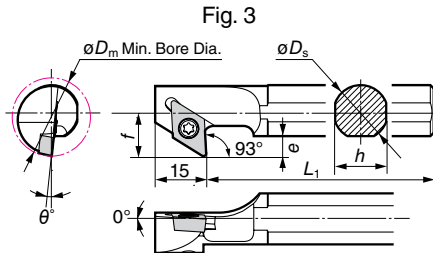
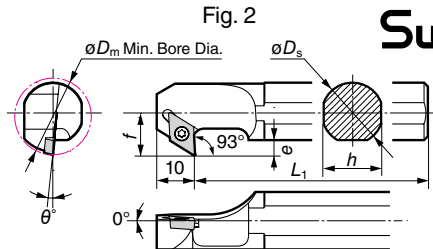
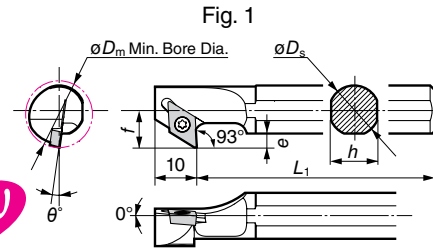

Sumi Small

### ■ Spare Parts

■ Holder Right handed toolholders are applicable with left handed or neutral inserts.  
Left handed toolholders are applicable with right handed or neutral inserts.

Above figures show right hand tools.

Shank	Cat. No.	Stock		Min. Bore Dia.	Dimensions (mm)							Fig.	Applicable Insert	Screw	Recommended Tightening Torque (N·m)	Wrench
		R	L		$\phi D_m$	$\phi D_s$	$h$	$L_1$	$f$	$e$	$\theta^\circ$					
Steel	S10M-SDZC R/L0702-13			13	10	9	150	7.5	3.0	-8	1	DC □□0702□□	BFTX02506N	1.5	TRX08	
	S12M-SDZC R/L0702-16	●		16	12	11	150	9.0	3.5	-8						
	S16Q-SDZC R/L0702-20	●		20	16	15	180	11.0	4.0	-6	2	DC □□11T3□□	BFTX0409N	3.4	TRX15	
	S16Q-SDZC R/L11T3-23	●		23	16	15	180	13.0	6.0	-6						
	S20R-SDZC R/L11T3-25			25	20	18	200	14.5	6.0	-6	4	DC □□11T3□□	BFTX0409N	3.4	TRX15	
	S25S-SDZC R/L11T3-32			32	25	22	250	17.0	7.0	-6						

■ Insert ( Coated)

● 7° Relief E-Class

DCET FX	Cat. No.	ACZ150	Stock		Dimensions (mm)		
			Inscribed circle	Thickness	Nose Radius		
DCET 0702003R-FX		●				0.03	
DCET 0702003L-FX		●				0.03	
DCET 0702008R-FX		●				0.08	
DCET 0702008L-FX		●				0.08	
DCET 070201R-FX		●				0.1	
DCET 070201L-FX		●		6.35	2.38	0.1	
DCET 0702018R-FX		●				0.18	
DCET 0702018L-FX		●				0.18	
DCET 070204R-FX		●				0.4	
DCET 070204L-FX		●				0.4	
DCET 11T3003R-FX		●				0.03	
DCET 11T3003L-FX		●				0.03	
DCET 11T3008R-FX		●				0.08	
DCET 11T3008L-FX		●				0.08	
DCET 11T301R-FX		●				0.1	
DCET 11T301L-FX		●		9.525	3.97	0.1	
DCET 11T3018R-FX		●				0.18	
DCET 11T3018L-FX		●				0.18	
DCET 11T304R-FX		●				0.4	
DCET 11T304L-FX		●				0.4	

● 7° Relief E-Class

DCET FY	Cat. No.	ACZ150	Stock		Dimensions (mm)		
			Inscribed circle	Thickness	Nose Radius		
DCET 0702003R-FY		●				0.03	
DCET 0702003L-FY		●				0.03	
DCET 0702008R-FY		●				0.08	
DCET 0702008L-FY		●				0.08	
DCET 070201R-FY		●				0.1	
DCET 070201L-FY		●		6.35	2.38	0.1	
DCET 0702018R-FY		●				0.18	
DCET 0702018L-FY		●				0.18	
DCET 070204R-FY		●				0.4	
DCET 070204L-FY		●				0.4	
DCET 11T3003R-FY		●				0.03	
DCET 11T3003L-FY		●				0.03	
DCET 11T3008R-FY		●				0.08	
DCET 11T3008L-FY		●				0.08	
DCET 11T301R-FY		●				0.1	
DCET 11T301L-FY		●		9.525	3.97	0.1	
DCET 11T3018R-FY		●				0.18	
DCET 11T3018L-FY		●				0.18	
DCET 11T304R-FY		●				0.4	
DCET 11T304L-FY		●				0.4	

# SEC-Boring Bars SDUC/SDQC Type



■ Insert ( Coated / Cermet / Carbide)

● 7° Relief G-Class

DCGT FC	Stock	Stock					Dimensions (mm)		
		AC520U	AC530U	ACZ150	T1000A	T1500A	Inscribed circle	Thickness	Nose Radius
Cat. No.									
DCGT 070201MN-FC	●	●	●	●	●	6.35	2.38	<0.1	
070202MN-FC	●	●	●	●	<0.2				
070204MN-FC	●	●	●	●	<0.4				
DCGT 11T301MN-FC	●	●	●	●	●	9.525	3.97	<0.1	
11T302MN-FC	●	●	●	●	<0.2				
11T304MN-FC	●	●	●	●	<0.4				

Values for nose radius prefixed with "<" mean minus tolerances.

● 7° Relief G-Class

DCGT SI	Stock	Stock						Dimensions (mm)			
		AC610M	AC630M	AC510U	AC520U	AC530U	T1500Z	T1000A	T1500A	Inscribed circle	Thickness
Cat. No.											
DCGT 070201MN-SI	●	●	●	●	●	●	●	●	6.35	2.38	<0.1
070202MN-SI	●	●	●	●	●	●	●	<0.2			
070204MN-SI	●	●	●	●	●	●	●	<0.4			
DCGT 11T301MN-SI	●	●	●	●	●	●	●	9.525	3.97	<0.1	
11T302MN-SI	●	●	●	●	●	●	●			<0.2	
11T304MN-SI	●	●	●	●	●	●	●			<0.4	
11T308MN-SI	●	●	●	●	●	●	●	<0.8			

Values for nose radius prefixed with "<" mean minus tolerances.

DCGT FX	Stock	Stock						Dimensions (mm)		
		AC520U	AC530U	T1500Z	T1000A	T1500A	T110A	T1200A	Inscribed circle	Thickness
Cat. No.										
DCGT 0702003R-FX	●	●	●	●	●	●	▲	6.35	2.38	0.03
0702003L-FX	●	●	●	●	●	●	▲			0.03
070201R-FX	●	●	●	●	●	●	▲			0.1
070201L-FX	●	●	●	●	●	●	▲			0.1
070202R-FX	●	●	●	●	●	●	▲			0.2
070202L-FX	●	●	●	●	●	●	▲			0.2
070204R-FX	●	●	●	●	●	●	▲			0.4
DCGT 11T3003R-FX	●	●	●	●	●	●	▲	9.525	3.97	0.03
11T3003L-FX	●	●	●	●	●	●	▲			0.03
11T301R-FX	●	●	●	●	●	●	▲			0.1
11T301L-FX	●	●	●	●	●	●	▲			0.1
11T302R-FX	●	●	●	●	●	●	▲			0.2
11T302L-FX	●	●	●	●	●	●	▲			0.2
11T302L-FX	●	●	●	●	●	●	▲			0.2

DCGT SC	Stock	Stock						Dimensions (mm)		
		AC530U	ACZ150	T1500Z	T1000A	T1500A	T1200A	Inscribed circle	Thickness	Nose Radius
Cat. No.										
DCGT 0702003N-SC	●	●	●	●	●	●	▲	6.35	2.38	0.03
DCGT 070201MN-SC	●	●	●	●	●	●	▲			<0.1
070202MN-SC	●	●	●	●	●	●	▲			<0.2
DCGT 070204MN-SC	●	●	●	●	●	●	▲	<0.4		
DCGT 11T3003N-SC	●	●	●	●	●	●	▲	9.525	3.97	0.03
DCGT 11T301MN-SC	●	●	●	●	●	●	▲			<0.1
11T302MN-SC	●	●	●	●	●	●	▲			<0.2
11T304MN-SC	●	●	●	●	●	●	▲			<0.4
11T308MN-SC	●	●	●	●	●	●	▲			<0.8

Values for nose radius prefixed with "<" mean minus tolerances.

DCGT FY	Stock	Stock					Dimensions (mm)		
		AC520U	AC530U	T1000A	T1500A		Inscribed circle	Thickness	Nose Radius
Cat. No.									
DCGT 0702003R-FY	●	●	●	●	●	6.35	2.38	0.03	
0702003L-FY	●	●	●	●	●			0.03	
070201R-FY	●	●	●	●	●			0.1	
070201L-FY	●	●	●	●	●			0.1	
070202R-FY	●	●	●	●	●			0.2	
070202L-FY	●	●	●	●	●			0.2	
070204R-FY	●	●	●	●	●			0.4	
DCGT 11T3003R-FY	●	●	●	●	●	9.525	3.97	0.03	
11T3003L-FY	●	●	●	●	●			0.03	
11T301R-FY	●	●	●	●	●			0.1	
11T301L-FY	●	●	●	●	●			0.1	
11T302R-FY	●	●	●	●	●			0.2	
11T302L-FY	●	●	●	●	●			0.2	
11T304R-FY	●	●	●	●	●			0.4	
11T304L-FY	●	●	●	●	●	0.4			

DCGT AG	Stock	Stock						Dimensions (mm)		
								Inscribed circle	Thickness	Nose Radius
Cat. No.										
DCGT 070202N-AG	●							6.35	2.38	0.2
070204N-AG	●									0.4
DCGT 11T302N-AG	●							9.525	3.97	0.2
11T304N-AG	●									0.4
11T308N-AG	●							0.8		

DCGT AY	Stock	Stock						Dimensions (mm)		
								Inscribed circle	Thickness	Nose Radius
Cat. No.										
DCGT 070201R-AY	●							6.35	2.38	0.1
070201L-AY	●									0.1
070202R-AY	●									0.2
070202L-AY	●									0.2
070204R-AY	●									0.4
070204L-AY	●									0.4
DCGT 11T301R-AY	●									9.525
11T301L-AY	●							0.1		
11T302R-AY	●							0.2		
11T302L-AY	●							0.2		
11T304R-AY	●							0.4		
11T304L-AY	●							0.4		

DCGT SD	Stock	Stock					Dimensions (mm)		
		T1500Z	T1000A	T1500A	T110A	T1200A	Inscribed circle	Thickness	Nose Radius
Cat. No.									
DCGT 070202R-SD	●	●	●	●	▲	6.35	2.38	0.2	
070202L-SD	●	●	●	●	▲			0.2	
070204R-SD	●	●	●	●	▲			0.4	
070204L-SD	●	●	●	●	▲			0.4	
DCGT 11T304R-SD	●	●	●	●	▲	9.525	3.97	0.4	
11T304L-SD	●	●	●	●	▲			0.4	
11T308R-SD	●	●	●	●	▲			0.8	
11T308L-SD	●	●	●	●	▲			0.8	

DCGW	Stock	Stock						Dimensions (mm)		
		AC503U						Inscribed circle	Thickness	Nose Radius
Cat. No.										
DCGW 070202	●							6.35	2.38	0.2
070204	●									0.4
070208	●									0.8
DCGW 11T302	●							9.525	3.97	0.2
11T304	●									0.4
11T308	●									0.8



# SEC-Boring Bars SDUC/SDQC Type

■ Insert ( Coated / Cermet / Carbide / SUMIBORON )

## ● 7° Relief M-Class

DCMT FB		Stock						Dimensions (mm)		
		AC530U	T1500Z	T3000Z	T1000A	T1500A	Inscribed circle	Thickness	Nose Radius	
Cat. No.										
DCMT 070202N-FB		●								0.2
DCMT 070204N-FB		●					6.35	2.38		0.4
DCMT 070208N-FB		●								0.8
DCMT 11T302N-FB		●								0.2
DCMT 11T304N-FB		●					9.525	3.97		0.4
DCMT 11T308N-FB		●								0.8

DCMT LU		Stock								Dimensions (mm)				
		AC810P	AC820P	AC630M	AC6030M	AC6040M	AC530U	T1500Z	T3000Z	T1000A	T1500A	Inscribed circle	Thickness	Nose Radius
Cat. No.														
DCMT 070202N-LU		●	●	●	●	●	●	●	●	●	●	6.35	2.38	0.2
DCMT 070204N-LU		●	●	●	●	●	●	●	●	●	●			0.4
DCMT 11T302N-LU		●	●	●	●	●	●	●	●	●	●			0.2
DCMT 11T304N-LU		●	●	●	●	●	●	●	●	●	●	9.525	3.97	0.4
DCMT 11T308N-LU		●	●	●	●	●	●	●	●	●	●			0.8

DCMT FP		Stock						Dimensions (mm)		
		T1500A	Inscribed circle	Thickness	Nose Radius	Inscribed circle	Thickness	Nose Radius		
Cat. No.										
DCMT 070202N-FP		●					6.35	2.38		0.2
DCMT 070204N-FP		●								0.4
DCMT 11T308N-FP		●					9.525	3.97		0.8

DCMT LB		Stock						Dimensions (mm)		
		AC820P	AC830P	AC6030M	AC6040M	T1500Z	T3000Z	T1500A	Inscribed circle	Thickness
Cat. No.										
DCMT 070202N-LB		●	●	●	●	●	●	●	●	0.2
DCMT 070204N-LB		●	●	●	●	●	●	●	●	0.4
DCMT 070208N-LB		●	●	●	●	●	●	●	●	0.8
DCMT 11T302N-LB		●	●	●	●	●	●	●	●	0.2
DCMT 11T304N-LB		●	●	●	●	●	●	●	●	0.4
DCMT 11T308N-LB		●	●	●	●	●	●	●	●	0.8

DCMT SU		Stock								Dimensions (mm)				
		AC810P	AC820P	AC610M	AC630M	AC6030M	AC6040M	AC530U	T1500Z	T3000Z	T1000A	T1500A	Inscribed circle	Thickness
Cat. No.														
DCMT 070202N-SU		●	●	●	●	●	●	●	●	●	●	6.35	2.38	0.2
DCMT 070204N-SU		●	●	●	●	●	●	●	●	●	●			0.4
DCMT 070208N-SU		●	●	●	●	●	●	●	●	●	●			0.8
DCMT 11T302N-SU		●	●	●	●	●	●	●	●	●	●			0.2
DCMT 11T304N-SU		●	●	●	●	●	●	●	●	●	●	9.525	3.97	0.4
DCMT 11T308N-SU		●	●	●	●	●	●	●	●	●	●			0.8

DCMT MU		Stock						Dimensions (mm)						
		AC810P	AC830P	AC2000	AC630M	AC6030M	AC405K	AC415K	AC420K	AC410K	Inscribed circle	Thickness	Nose Radius	
Cat. No.														
DCMT 11T304N-MU		●	●	▲	●	●	●	●	●	●	●	9.525	3.97	0.4
DCMT 11T308N-MU		●	●	▲	●	●	●	●	●	●	●			0.8

DCMW		Stock				Dimensions (mm)		
		AC405K	AC415K	AC420K	AC410K	Inscribed circle	Thickness	Nose Radius
Cat. No.								
DCMW 070204		●	●	●	▲	6.35	2.38	0.4
DCMW 070208		●	●	●	▲			0.8
DCMW 11T304		●	●	●	▲	9.525	3.97	0.4
DCMW 11T308		●	●	●	▲			0.8

## ● 7° Relief G-Class

### ● Coated SUMIBORON One-use Type/Multi corner

2NC- DCGW		Stock						Dimensions (mm)			
		BNC2010	BNC2020	BNC100	BNC160	BNC200	BNC300	BNC500	Inscribed circle	Thickness	Nose Radius
Cat. No.											
2NC-DCGW 070202		●	●						6.35	2.38	0.2
2NC-DCGW 070204		●	●								0.4
2NC-DCGW 070202LS		●	●								0.2
2NC-DCGW 070204LS		●	●								0.4
2NC-DCGW 11T302		●	●								0.2
2NC-DCGW 11T304		●	●								0.4
2NC-DCGW 11T308		●	●								0.8
2NC-DCGW 11T304-WG		●	●								0.4
2NC-DCGW 11T308-WG		●	●								0.8
2NC-DCGW 11T304-WH		●	●								0.4
2NC-DCGW 11T308-WH		●	●								0.8
2NC-DCGW 11T302LS		●	●								0.2
2NC-DCGW 11T304LS		●	●								0.4
2NC-DCGW 11T308LS		●	●								0.8
2NC-DCGW 11T304HS											0.4
2NC-DCGW 11T308HS											0.8

\*WG/WH: Wiper Insert LS: for fine boring of hardened steel HS: for Strong Edge Type

## ● Coated SUMIBORON Break Master

2NC- DCGT FV/LV		Stock				Dimensions (mm)		
		BNC2010	BNC2020	BNC160	BNC200	Inscribed circle	Thickness	Nose Radius
Cat. No.								
2NC-DCGT 070204N-FV		●	●			6.35	2.38	0.4
2NC-DCGT 11T304N-FV		●	●					0.4
2NC-DCGT 11T308N-FV		●	●					0.8
2NC-DCGT 11T304N-LV		●	●			9.525	3.97	0.4
2NC-DCGT 11T308N-LV		●	●					0.8

▲ mark : To be replaced by new item (Please confirm stock availability)

# SEC-Boring Bars SDUC/SDQC Type



■ Insert (SUMIBORON / SUMIDIA)

- 7° Relief G-Class
- SUMIBORON One-use Type
- (▲ : 1pc. per package stock, ▲ : 1pc. per package and 10pc. per package stock)

NU-DCGW	Stock	Stock					Dimensions (mm)		
		BN1000	BN2000	BN250	BN7000	BN700	Inscribed circle	Thickness	Nose Radius
Cat. No.									
NU-DCGW 070202	●	●	▲	●	●	6.35	2.38	0.2	
070204	●	●	▲	●	0.4				
070208	●	●	●	●	0.8				
070202LT	—	●	—	—	0.2				
070204LT	—	●	—	—	0.4				
070208LT	—	●	—	—	0.8				
070202LS	—	—	▲	—	0.2				
070204LS	—	—	▲	—	0.4				
070208LS	—	—	▲	—	0.8				
070202HS	—	●	—	—	0.2				
070204HS	—	●	—	—	0.4				
NU-DCGW 11T302	●	●	▲	●	9.525	3.97	0.2		
11T304	●	●	▲	●				0.4	
11T308	●	●	●	●				0.8	
11T312	—	●	—	—				1.2	
11T302LF	—	—	—	●				0.2	
11T304LF	—	—	—	●				0.4	
11T302LT	—	●	—	—				0.2	
11T304LT	—	●	—	—				0.4	
11T308LT	—	●	—	—				0.8	
11T312LT	—	●	—	—				1.2	
11T302LS	—	—	▲	—				0.2	
11T304LS	—	—	▲	—				0.4	
11T308LS	—	—	▲	—				0.8	
11T312LS	—	—	—	—				1.2	
11T302HS	—	●	—	—				0.2	
11T304HS	—	●	—	—				0.4	
11T308HS	—	●	—	—				0.8	

\* LF: for sintered component and cast iron machining LT: for fine boring of hardened steel LS: Continuous cutting HS: for Strong Edge Type

- Uncoated SUMIBORON One-use Type/Multi corner
- (● : 1pc. per package stock, ● : 1pc. per package and 10pc. per package stock)

2NU-DCGW	Stock	Stock			Dimensions (mm)		
		BN2000	BN7000	BN7500	Inscribed circle	Thickness	Nose Radius
Cat. No.							
2NU-DCGW 070204	●	●	●	●	6.35	2.38	0.4
070208	●	●	●	0.8			
2NU-DCGW 11T302	●	●	●	9.525			
11T304	●	●	●		0.4		
11T308	●	●	●		0.8		
11T304WG	●	—	—		0.4		
11T308WG	●	—	—		0.8		
11T304WH	●	—	—		0.4		
11T308WH	●	—	—		0.8		
11T302LF	—	●	—		0.2		
11T304LF	—	●	—		0.4		
11T302LE	—	—	●		0.2		
11T304LE	—	—	●		0.4		
11T302LS	—	—	●		0.2		
11T304LS	—	—	●		0.4		

\* WG/WH: Wiper Insert LF/LE: for sintered component and cast iron machining LS: Continuous cutting

- Uncoated SUMIBORON Break Master

2NU-DCGT	Stock	Stock			Dimensions (mm)			
		BN2000			Inscribed circle	Thickness	Nose Radius	
Cat. No.								
2NU-DCGT 070204N-FV	●	●	—	—	6.35	2.38	0.4	
2NU-DCGT 11T304N-FV	●	●	—	—				0.4
11T308N-FV	●	●	—	—	9.525	3.97	0.8	
11T304N-LV	●	●	—	—				0.4
11T308N-LV	●	●	—	—				0.8

- 7° Relief G-Class
- SUMIDIA (NF Type)

NF-DCMT	Stock	Stock				Dimensions (mm)		
		DA1000	DA2200			Inscribed circle	Thickness	Nose Radius
Cat. No.								
NF-DCMT 070201	●	▲	—	—	6.35	2.38	0.1	
070202	●	▲	—	—				0.2
070204	●	▲	—	—				0.4
NF-DCMT 11T301	●	▲	—	—	9.525	3.97	0.1	
11T302	●	▲	—	—				0.2
11T304	●	▲	—	—				0.4
11T308	●	▲	—	—				0.8

- SUMIDIA (Break Master)

NF-DCMT	Stock	Stock				Dimensions (mm)		
		DA1000				Inscribed circle	Thickness	Nose Radius
Cat. No.								
NF-DCMT 070202N-LD	●	—	—	—	6.35	2.38	0.2	
070204N-LD	●	—	—	—				0.4
070202N-GD	●	—	—	—				0.2
NF-DCMT 070204N-GD	●	—	—	—	9.525	3.97	0.4	
NF-DCMT 11T302N-LD	●	—	—	—				0.2
11T304N-LD	●	—	—	—				0.4
11T308N-LD	●	—	—	—				0.8
11T302N-GD	●	—	—	—	9.525	3.97	0.2	
11T304N-GD	●	—	—	—				0.4
11T308N-GD	●	—	—	—				0.8
11T308N-GD	●	—	—	—				0.8

\*LD: For Finishing, GD: For Medium Finishing

NU-DCMT	Stock	Stock				Dimensions (mm)		
		DA150				Inscribed circle	Thickness	Nose Radius
Cat. No.								
NU-DCMT 070202R-DM	●	—	—	—	6.35	2.38	0.2	
070202L-DM	●	—	—	—				0.2
070204R-DM	●	—	—	—				0.4
070204L-DM	●	—	—	—	9.525	3.97	0.4	
NU-DCMT 11T302R-DM	●	—	—	—				0.2
11T302L-DM	●	—	—	—				0.2
11T304R-DM	●	—	—	—				0.4
11T304L-DM	●	—	—	—	0.4			

- SUMIDIA

DCMT	Stock	Stock				Dimensions (mm)		
		DA150	DA2200			Inscribed circle	Thickness	Nose Radius
Cat. No.								
DCMT 070201	●	▲	—	—	6.35	2.38	0.1	
070202	●	▲	—	—				0.2
070204	●	▲	—	—				0.4
DCMT 11T301	●	▲	—	—	9.525	3.97	0.1	
11T302	●	▲	—	—				0.2
11T304	●	▲	—	—				0.4

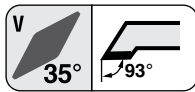

# SEC-Boring Bars S-SVJB/B-SVJB/S-SVJC Type

## Internal Copying

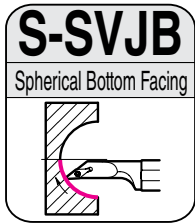

Steel

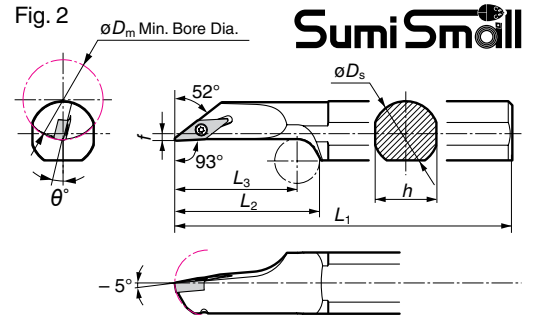
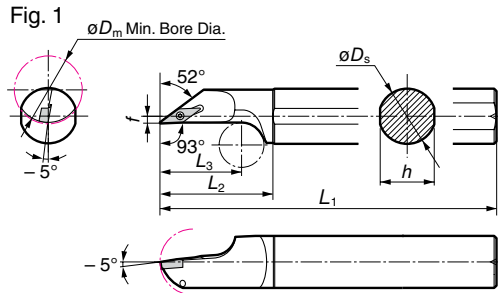

Sumi Small

### Holder

Right handed toolholders are applicable with left handed or neutral inserts.  
Left handed toolholders are applicable with right handed or neutral inserts. Above figures show right hand tools.

Shank	Cat. No.	Stock		Min. Bore Dia.	Dimensions (mm)							Fig.	Applicable Insert Cat. No.	Pin	Bolt	Shim	Screw	Recommended Tightening Torque (N·m)	Wrench	Screw Spanner
		R	L		$\phi D_m$	$\phi D_s$	$h$	$L_1$	$f$	$L_2$	$L_3$									
Steel	S20R-SVJB R/L1103-25	●	●	25	20	19	200	2.0	42	29	—	1	VB□□1103□□	—	—	—	BFTX02508NV*	1.5	TRX08	—
	S25S-SVJB R/L1103-30	●	●	30	25	24	250	3.5	50	36	—									
	S32T-SVJB R/L1604-40	●	●	40	32	30	300	3.5	75	60	-8									
	S40T-SVJB R/L1604-50	●	●	50	40	37	300	4.5	95	75	-7									
											2	VB□□1604□□	VP32B VP40B	BH03504	SVP32	BFTX03508*	2.0	TRX10	LH020	

\* Changed from those in the 2013-2014 General Catalog.

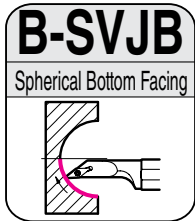

Anti-vibration

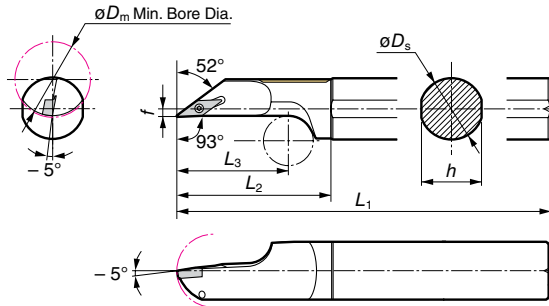

SumiTurn X-Bar

Sumi Small

### Holder

Right handed toolholders are applicable with left handed or neutral inserts.  
Left handed toolholders are applicable with right handed or neutral inserts. Above figures show right hand tools.

Shank	Cat. No.	Stock		Min. Bore Dia.	Dimensions (mm)						Applicable Insert Cat. No.	Screw	Recommended Tightening Torque (N·m)	Wrench
		R	L		$\phi D_m$	$\phi D_s$	$h$	$L_1$	$f$	$L_2$				
Anti-vibration	B20R-SVJB R/L1103-25	●	●	25	20	19	200	2.0	55	37.5	VB□□1103□□	BFTX02508NV*	1.5	TRX08
	B25S-SVJB R/L1103-30	●	●	30	25	24	250	3.5	62	45				

\* Changed from those in the 2013-2014 General Catalog.

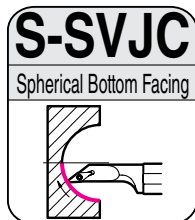

Steel

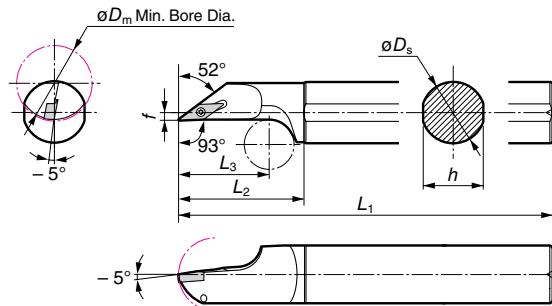

Sumi Small

### Holder

Right handed toolholders are applicable with left handed or neutral inserts.  
Left handed toolholders are applicable with right handed or neutral inserts. Above figures show right hand tools.

Shank	Cat. No.	Stock		Min. Bore Dia.	Dimensions (mm)						Applicable Insert	Screw	Recommended Tightening Torque (N·m)	Wrench
		R	L		$\phi D_m$	$\phi D_s$	$h$	$L_1$	$f$	$L_2$				
Steel	S12M-SVJC R/L0802-16	●	●	16	12	11	150	2.0	30	21	VC□□0802□□	BFTX0204N	0.5	TRX06
	S16Q-SVJC R/L0802-20	●	●	20	16	15	180	2.0	40	29				

Boring Bars

# SEC-Boring Bars S-SVQB/B-SVQB/C-SVQB Type

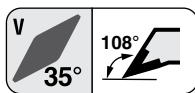

## Internal Copying

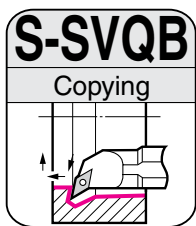

**Steel**

*New*

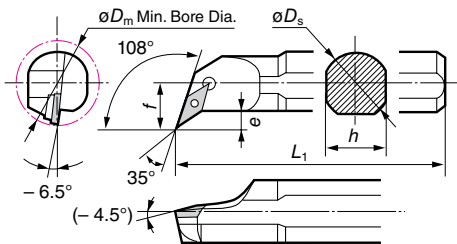

■ **Holder** Right handed toolholders are applicable with left handed or neutral inserts.  
Left handed toolholders are applicable with right handed or neutral inserts. Above figures show right hand tools.

### ■ Spare Parts

Pin	Bolt	Shim	Screw	Recommended Tightening Torque (N·m)	Wrench	Screw Spanner
—	—	—	BFTX02508NV	1.5	TRX08	—
VP32B VP40B	BH03504	SVP32	BFTX03508	2.0	TRX10	LH020

Shank	Cat. No.	Stock		Dimensions (mm)					Applicable Insert	Pin	Bolt	Shim	Screw	Recommended Tightening Torque (N·m)	Wrench	Screw Spanner	
		R	L	$\phi D_m$	$\phi D_s$	h	$L_1$	f									e
Steel	<b>S20R-SVQB R/L1103-25</b>	●	●	25	20	18	200	14.5	5.5	VB □ □ 1103 □ □	—	—	—	BFTX02508NV	1.5	TRX08	—
	<b>S25S-SVQB R/L1103-32</b>	●	●	32	25	23	250	19.0	7.5	—	—	—	—	—	—	—	
	<b>S25S-SVQB R/L1604-34</b>	●	●	34	25	23	250	20.5	9.0	VB □ □ 1604 □ □	—	—	—	—	—	—	
	<b>S32T-SVQB R/L1604-40</b>	●	●	40	32	30	300	22.0	9.0	—	—	—	—	—	—	—	
	<b>S40T-SVQB R/L1604-50</b>	●	●	50	40	37	300	27.0	10.0	—	—	—	—	—	—	—	

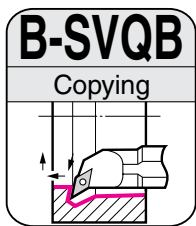

**Anti-vibration**

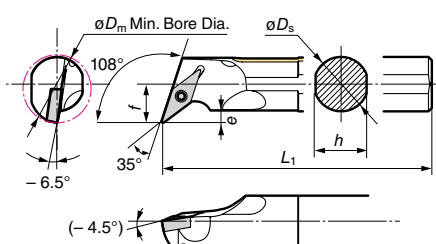

■ **Holder** Right handed toolholders are applicable with left handed or neutral inserts.  
Left handed toolholders are applicable with right handed or neutral inserts. Above figures show right hand tools.



Shank	Cat. No.	Stock		Dimensions (mm)					Applicable Insert	Screw	Recommended Tightening Torque (N·m)	Wrench	
		R	L	$\phi D_m$	$\phi D_s$	h	$L_1$	f					e
Anti-vibration	<b>B16R-SVQB R/L1103-20</b>	●	●	20	16	15	200	11.5	4	VB □ □ 1103 □ □	BFTX02508NV*	1.5	TRX08
	<b>B20R-SVQB R/L1103-25</b>	●	●	25	20	18	200	14.5	5	—	—	—	—

\* Changed from those in the 2013-2014 General Catalog.

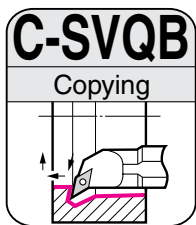

**Carbide**

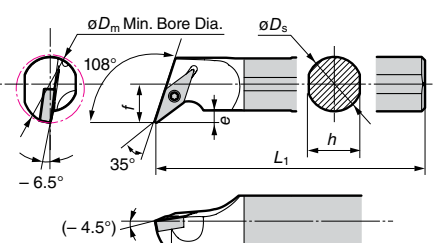

■ **Holder** Right handed toolholders are applicable with left handed or neutral inserts.  
Left handed toolholders are applicable with right handed or neutral inserts. Above figures show right hand tools.



Shank	Cat. No.	Stock		Dimensions (mm)					Applicable Insert	Screw	Recommended Tightening Torque (N·m)	Wrench	
		R	L	$\phi D_m$	$\phi D_s$	h	$L_1$	f					e
Carbide	<b>C16R-SVQB R/L1103-20</b>	●	●	20	16	15	200	11.5	4	VB □ □ 1103 □ □	BFTX02508NV*	1.5	TRX08
	<b>C20R-SVQB R/L1103-25</b>	●	●	25	20	18	200	14.5	5	—	—	—	—

\* Changed from those in the 2013-2014 General Catalog.



# SEC-Boring Bars S-SVQC/S-SVUB Type



## Internal Copying

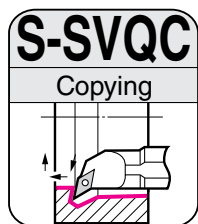

Steel

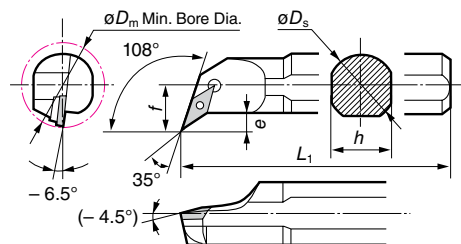

### Spare Parts

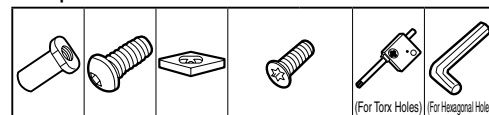

■ Holder Right handed toolholders are applicable with left handed or neutral inserts.  
Left handed toolholders are applicable with right handed or neutral inserts. Above figures show right hand tools.

Shank	Cat. No.	Conventional Cat. No.	Stock		Dimensions (mm)						Applicable Insert	Pin	Bolt	Shim	Screw	Recommended Tightening Torque (N·m)	Wrench	Screw Spanner
			R	L	$\theta D_m$	$\theta D_s$	$h$	$L_1$	$f$	$e$								
Steel	S10M-SVQC R/L0802-14	—	●	●	14	10	9	150	8.5	4.5	VC□□0802□□	—	—	—	BFTX0204N	0.5	TRX06	—
	S12M-SVQC R/L0802-16	—	●	●	16	12	11	150	9.5	4.5	VC□□1103□□	—	—	—	BFTX02508NV	1.5	TRX08	—
	S16Q-SVQC R/L1103-20	—	●	●	20	16	15	180	11.5	4.5	VC□□1103□□	—	—	—	BFTX02508NV	1.5	TRX08	—
	S25R-SVQC R/L1604-35	S25R-SVQC R/L16	▲	▲	35	25	23	200	20.5	9.0	VC□□1604□□	—	—	—	BFTX03508	2.0	TRX10	—
	S32S-SVQC R/L1604-40	S32S-SVQC R/L16	▲	▲	40	32	30	250	22.0	9.0	VC□□1604□□	VP32B	BH03504	SVP32	BFTX03508	2.0	TRX10	LH020
S40T-SVQC R/L1604-50	S40T-SVQC R/L16	▲	▲	50	40	37	300	27.0	10.0	VC□□1604□□	VP40B	BH03504	SVP32	BFTX03508	2.0	TRX10	LH020	

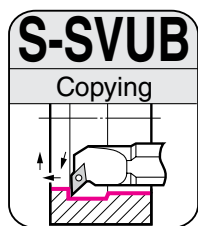

Steel

New

Fig. 1

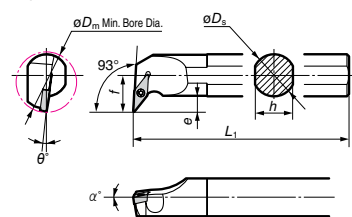

Fig. 2

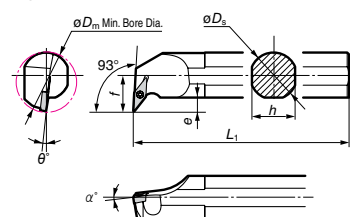
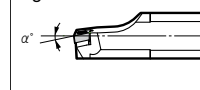
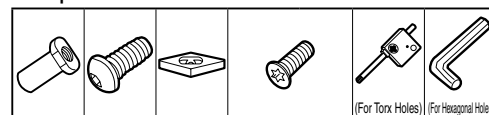

Fig. 3



### Spare Parts



■ Holder Right handed toolholders are applicable with left handed or neutral inserts.  
Left handed toolholders are applicable with right handed or neutral inserts. Above figures show right hand tools.

Shank	Cat. No.	Stock		Dimensions (mm)						Fig.	Applicable Insert	Pin	Bolt	Shim	Screw	Recommended Tightening Torque (N·m)	Wrench	Screw Spanner		
		R	L	$\theta D_m$	$\theta D_s$	$h$	$L_1$	$f$	$e$										$\theta$	$\alpha$
Steel	S20R-SVUB R/L1103-28	●	●	28	20	18	200	17.5	7.5	-7.5	-3.0	1	VB□□1103□□	—	—	—	BFTX02508NV	1.5	TRX08	—
	S25S-SVUB R/L1103-32	●	●	32	25	23	250	19.0	7.5	-6.5	-2.5	2	VB□□1103□□	—	—	—	BFTX02508NV	1.5	TRX08	—
	S25S-SVUB R/L1604-34	●	●	34	25	23	250	20.5	9.0	—	—	2	VB□□1604□□	—	—	—	BFTX02508NV	1.5	TRX08	—
	S32T-SVUB R/L1604-40	●	●	40	32	30	300	23.5	10.5	-7.5	-3.0	3	VB□□1604□□	VP32B	BH03504	SVP32	BFTX03508	2.0	TRX10	LH020
	S40T-SVUB R/L1604-50	●	●	50	40	37	300	29.5	12.5	—	—	3	VB□□1604□□	VP40B	BH03504	SVP32	BFTX03508	2.0	TRX10	LH020

# SEC-Boring Bars B-SVUB/C-SVUB/S-SVUC Type

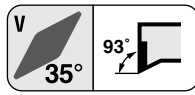

## Internal Copying

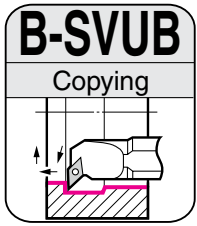

Anti-vibration

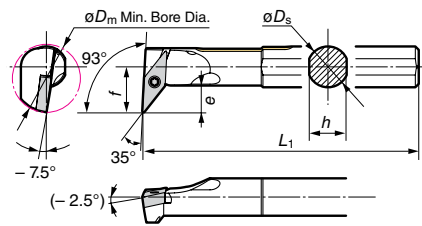

**Holder** Right handed toolholders are applicable with left handed or neutral inserts.  
Left handed toolholders are applicable with right handed or neutral inserts.

Above figures show right hand tools.

Shank	Cat. No.	Stock		Dimensions (mm)					Applicable Insert	Screw	Recommended Tightening Torque (N·m)	Wrench	
		R	L	$\phi D_m$	$\phi D_s$	$h$	$L_1$	$f$					$e$
Anti-vibration	<b>B12M-SVUB R/L1103-20</b>	●		20	12	11	150	13.5	8	VB □□1103□□	BFTX02508NV*	1.5	TRX08
	<b>B16R-SVUB R/L1103-25</b>	●		25	16	15	200	16.5	9				

\* Changed from those in the 2013-2014 General Catalog.

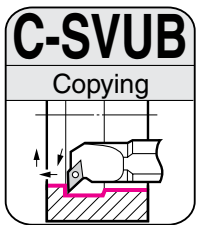

Carbide

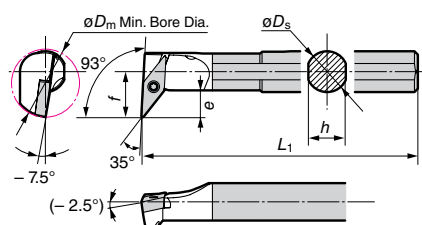

**Holder** Right handed toolholders are applicable with left handed or neutral inserts.  
Left handed toolholders are applicable with right handed or neutral inserts.

Above figures show right hand tools.

Shank	Cat. No.	Stock		Dimensions (mm)					Applicable Insert	Screw	Recommended Tightening Torque (N·m)	Wrench	
		R	L	$\phi D_m$	$\phi D_s$	$h$	$L_1$	$f$					$e$
Carbide	<b>C12M-SVUB R/L1103-20</b>	●		20	12	11	150	13.5	8	VB □□1103□□	BFTX02508NV*	1.5	TRX08
	<b>C16R-SVUB R/L1103-25</b>	●		25	16	15	200	16.5	9				

\* Changed from those in the 2013-2014 General Catalog.

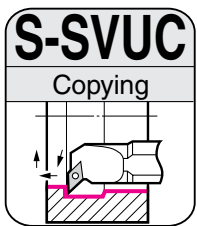

Steel

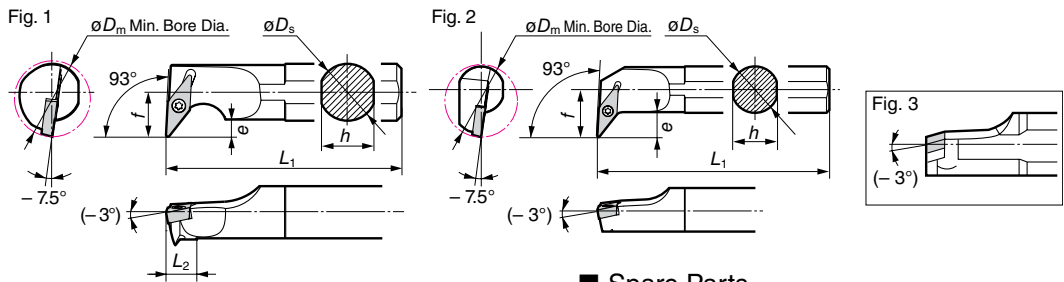

### Spare Parts

**Holder** Right handed toolholders are applicable with left handed or neutral inserts.  
Left handed toolholders are applicable with right handed or neutral inserts.

Above figures show right hand tools.

Shank	Cat. No.	Conventional Cat. No.	Stock		Dimensions (mm)					Fig.	Applicable Insert	Pin	Bolt	Shim	Screw	Recommended Tightening Torque (N·m)	Wrench	Screw Spanner		
			R	L	$\phi D_m$	$\phi D_s$	$h$	$L_1$	$f$										$L_2$	$e$
Steel	<b>S12M-SVUC R/L0802-16</b>	—	●		16	12	11	150	9.5	6.5	3.5	1	VC □□0802□□	—	—	—	BFTX0204N	0.5	TRX06	—
	<b>S16Q-SVUC R/L0802-20</b>	—	●		20	16	15	180	11.5	—	3.5	2	VC □□0802□□	—	—	—	BFTX02508NV	1.5	TRX08	—
	<b>S16Q-SVUC R/L1103-25</b>	—	●		25	16	15	180	16.5	—	8.5	2	VC □□1103□□	—	—	—	BFTX03508	2.0	TRX10	—
	<b>S25R-SVUC R/L1604-35</b>	S25R-SVUC R/L16	▲▲	▲	35	25	23	200	20.5	—	9.0	—	—	—	—	—	BFTX03508	2.0	TRX10	—
	<b>S32S-SVUC R/L1604-40</b>	S32S-SVUC R/L16	▲▲	▲	40	32	30	250	22.0	—	9.0	3	VC □□1604□□	VP32B VP40B	BH03504	SVP32	BFTX03508	2.0	TRX10	LH020

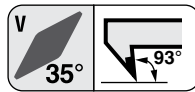

# SEC-Boring Bars S-SVZB/B-SVZB/C-SVZB Type

## Internal Copying

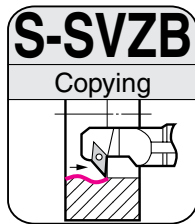

Steel

New

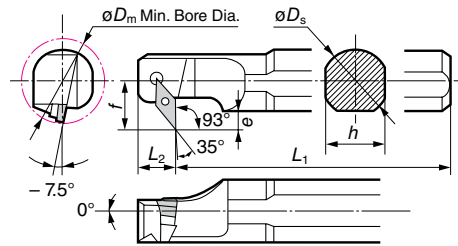

### Spare Parts

Pin	Bolt	Shim	Screw	Wrench	Screw Spanner
				(For Torx Holes)	(For Hexagonal Holes)

■ Holder Right handed toolholders are applicable with **right handed** or neutral inserts.  
Left handed toolholders are applicable with **left handed** or neutral inserts. Above figures show right hand tools.

Shank	Cat. No.	Stock		Dimensions (mm)							Applicable Insert	Pin	Bolt	Shim	Screw	Recommended Tightening Torque (N·m)	Wrench	Screw Spanner
		R	L	$\phi D_m$	$\phi D_s$	$h$	$L_1$	$L_2$	$f$	$e$								
Steel	<b>S20R-SVZB R/L1103-25</b>			25	20	18	200	15	14.5	5.5	VC □ □ 1103 □ □	—	—	—	BFTX02508NV	1.5	TRX08	—
	<b>S25S-SVZB R/L1103-32</b>			32	25	23	250	15	19.0	7.5	VC □ □ 1103 □ □	—	—	—	BFTX02508NV	1.5	TRX08	—
	<b>S25S-SVZB R/L1604-34</b>	●	●	34	25	23	250	20	20.5	9.0	VC □ □ 1604 □ □	—	—	—	BFTX03508	2.0	TRX10	—
	<b>S32T-SVZB R/L1604-40</b>	●	●	40	32	30	300	20	22.0	9.0	VC □ □ 1604 □ □	VP32B	BH03504	SVP32	BFTX03508	2.0	TRX10	LH020
	<b>S40T-SVZB R/L1604-50</b>	●	●	50	40	37	300	20	27.0	10.0	VC □ □ 1604 □ □	VP40B	BH03504	SVP32	BFTX03508	2.0	TRX10	LH020

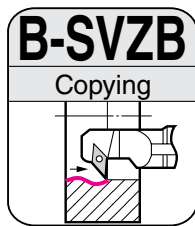

Anti-vibration

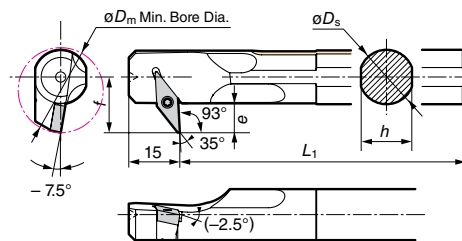

SumiTurn X-Bar

Sumi Small

■ Holder Right handed toolholders are applicable with **right handed** or neutral inserts.  
Left handed toolholders are applicable with **left handed** or neutral inserts. Above figures show right hand tools.

Shank	Cat. No.	Stock		Dimensions (mm)							Applicable Insert	Screw	Recommended Tightening Torque (N·m)	Wrench
		R	L	$\phi D_m$	$\phi D_s$	$h$	$L_1$	$f$	$e$					
Anti-vibration	<b>B12M-SVZB R/L1103-20</b> <b>B16R-SVZB R/L1103-25</b>	●	●	20	12	11	150	13.5	8	VB □ □ 1103 □ □	BFTX02508NV*	1.5	TRX08	

\* Changed from those in the 2013-2014 General Catalog.

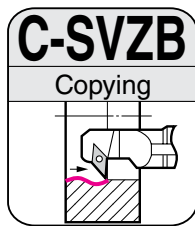

Carbide

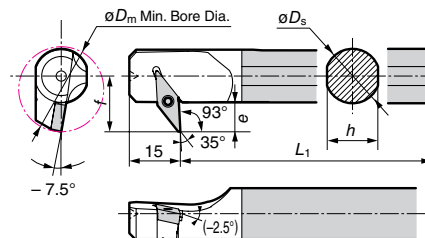

Sumi Small

■ Holder Right handed toolholders are applicable with **right handed** or neutral inserts.  
Left handed toolholders are applicable with **left handed** or neutral inserts. Above figures show right hand tools.

Shank	Cat. No.	Stock		Dimensions (mm)							Applicable Insert	Screw	Recommended Tightening Torque (N·m)	Wrench
		R	L	$\phi D_m$	$\phi D_s$	$h$	$L_1$	$f$	$e$					
Carbide	<b>C12M-SVZB R/L1103-20</b> <b>C16R-SVZB R/L1103-25</b>	●	●	20	12	11	150	13.5	8	VB □ □ 1103 □ □	BFTX02508NV*	1.5	TRX08	

\* Changed from those in the 2013-2014 General Catalog.

Boring Bars

# SEC-Boring Bars S-SVZC Type

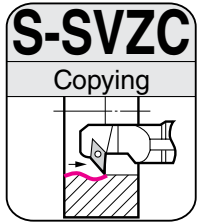
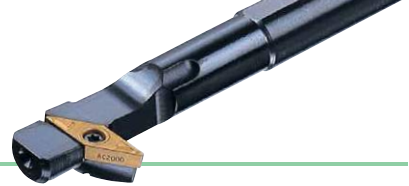
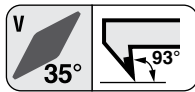

Steel

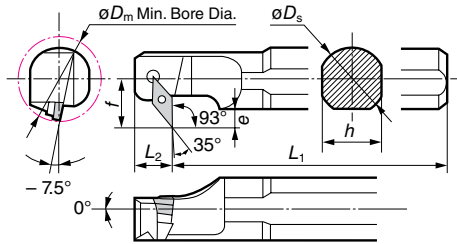

### ■ Spare Parts

Pin	Bolt	Shim	Screw	Recommended Tightening Torque (N·m)	Wrench	Screw Spanner
—	—	—	BFTX0204N	0.5	TRX06	—
—	—	—	BFTX02508NV	1.5	TRX08	—
—	—	—	—	—	—	—
VP32B	BH03504	SVP32	BFTX03508	2.0	TRX10	LH020
VP40B	—	—	—	—	—	—

■ Holder Right handed toolholders are applicable with **right handed** or neutral inserts.  
Left handed toolholders are applicable with **left handed** or neutral inserts. Above figures show right hand tools.

Shank	Cat. No.	Conventional Cat. No.	Stock		Dimensions (mm)							Applicable Insert
			R	L	$\phi D_m$	$\phi D_s$	$h$	$L_1$	$L_2$	$f$	$e$	
Steel	<b>S12M-SVZC R/L0802-16</b>	—	●	—	16	12	11	150	10	9.5	4.5	VC □ □ 0802 □ □
	<b>S16Q-SVZC R/L1103-20</b>	—	●	—	20	16	15	180	15	11.5	4.5	VC □ □ 1103 □ □
	<b>S25R-SVZC R/L1604-35</b>	S25R-SVZC R/L16	▲▲	—	35	25	23	200	20	20.5	9.0	—
	<b>S32S-SVZC R/L1604-40</b>	S32S-SVZC R/L16	▲▲	—	40	32	30	250	20	22.0	9.0	VC □ □ 1604 □ □
	<b>S40T-SVZC R/L1604-50</b>	S40T-SVZC R/L16	▲▲	—	50	40	37	300	20	27.0	10.0	—

E

Boring Bars



# SEC-Boring Bars SVJB/SVQB/SVUB/SVZB Type

■ Insert (  Coated /  Cermet /  Carbide )

## ● 5° Relief G-Class

VBGT FX		Stock					Dimensions (mm)		
		AC530U	T1500Z	T1000A	T1500A		Inscribed circle	Thickness	Nose Radius
Cat. No.									
VBGT 110301R-FX		●	●	●	●		6.35	3.18	0.1
110301L-FX		●	●	●	●				0.1
110302R-FX		●	●	●	●				0.2
110302L-FX		●	●	●	●				0.2
110304R-FX		●	●	●	●				0.4
110304L-FX		●	●	●	●		0.4		
VBGT 160402R-FX							9.525	4.76	0.2
160402L-FX									0.2
160404R-FX									0.4
160404L-FX									0.4

VBGT FY		Stock					Dimensions (mm)		
		AC503U	AC530U	T1500Z	T1000A	T1500A	Inscribed circle	Thickness	Nose Radius
Cat. No.									
VBGT 110301R-FY		●	●	●	●	●	6.35	3.18	0.1
110301L-FY		●	●	●	●	●			0.1
110302R-FY		●	●	●	●	●			0.2
110302L-FY		●	●	●	●	●			0.2
110304R-FY		●	●	●	●	●			0.4
110304L-FY		●	●	●	●	●	0.4		

VBGT AY		Stock					Dimensions (mm)		
		H1					Inscribed circle	Thickness	Nose Radius
Cat. No.									
VBGT 110301R-AY		●					6.35	3.18	0.1
110301L-AY		●							0.1
110302R-AY		●							0.2
110302L-AY		●							0.2
110304R-AY		●							0.4
110304L-AY		●					0.4		
VBGT 160402R-AY		●					9.525	4.76	0.2
160402L-AY		●							0.2
160404R-AY		●							0.4
160404L-AY		●							0.4

## ● 5° Relief M-Class

VBMT FB		Stock					Dimensions (mm)		
		AC530U	T1500Z	T3000Z	T1000A	T1500A	Inscribed circle	Thickness	Nose Radius
Cat. No.									
VBMT 110302N-FB		●	●	●	●	●	6.35	3.18	0.2
110304N-FB		●	●	●	●	●			0.4
110308N-FB		●	●	●	●	●			0.8
VBMT 160404N-FB		●	●	●	●	●	9.525	4.76	0.4
160408N-FB		●	●	●	●	●			0.8

VBMT LU		Stock								Dimensions (mm)				
		AC810P	AC820P	AC630M	AC6030M	AC6040M	AC530U	T1500Z	T3000Z	T1000A	T1500A	Inscribed circle	Thickness	Nose Radius
Cat. No.														
VBMT 110302N-LU							●	●	●	●	●	6.35	3.18	0.2
110304N-LU		●	●	●	●	●	●	●	●	●	0.4			
110308N-LU		●	●	●	●	●	●	●	●	●	0.8			
VBMT 160404N-LU		●	●	●	●	●	●	●	●	●	9.525	4.76	0.4	
160408N-LU		●	●	●	●	●	●	●	●	●			0.8	

## ● 5° Relief M-Class

VBMT LB		Stock						Dimensions (mm)			
		AC820P	AC830P	AC6030M	AC6040M	T1500Z	T3000Z	T1500A	Inscribed circle	Thickness	Nose Radius
Cat. No.											
VBMT 160404N-LB		●	●	●	●	●	●	●	9.525	4.76	0.4
160408N-LB		●	●	●	●	●	●	●			0.8
160412N-LB		●	●	●	●	●	●	●			1.2

VBMT SU		Stock										Dimensions (mm)						
		AC810P	AC820P	AC830P	AC2000	AC610M	AC630M	AC6030M	AC6040M	AC530U	T1500Z	T3000Z	T1000A	T1500A	T1200A	Inscribed circle	Thickness	Nose Radius
Cat. No.																		
VBMT 110302N-SU										●						6.35	3.18	0.2
110304N-SU						●	●	●		●					0.4			
110308N-SU						●	●	●		●					0.8			
VBMT 160404N-SU		●	●	●	▲	●	●	●		●	●	●	▲	▲	9.525	4.76	0.4	
160408N-SU		●	●	●	▲	●	●	●		●	●	●	▲	▲			0.8	
160412N-SU		●	●	●	▲	●	●	●		●	●	●	▲	▲			1.2	

VBMT —		Stock				Dimensions (mm)		
		AC405K	AC415K	AC420K	AC410K	Inscribed circle	Thickness	Nose Radius
Cat. No.								
VBMT 160404		●	●	●	▲	9.525	4.76	0.4
160408		●	●	●	▲			0.8

▲ mark : To be replaced by new item (Please confirm stock availability)

# SEC-Boring Bars SVJB/SVQB/SVUB/SVZB Type



■ Insert (  SUMIBORON)

● 5° Relief G-Class

● Uncoated SUMIBORON One-use Type

NU-VBGW		Stock					Dimensions (mm)				
		BN1000	BN2000	BN250	BN7000	BN700	Inscribed circle	Thickness	Nose Radius		
Cat. No.											
NU-VBGW 110302		●	●				6.35	2.38	0.2		
110304		●	●						0.4		
110308		●	●		●	●			0.8		
110302LT		—	●	—	—	—			0.2		
110304LT		—	●	—	—	—			0.4		
110308LT		—	●	—	—	—			0.8		
110302LS		—	—	▲	—	—			0.2		
110304LS		—	—	▲	—	—			0.4		
110308LS		—	—	▲	—	—			0.8		
110302HS		—	●	—	—	—			0.2		
110304HS		—	●	—	—	—			0.4		
110308HS		—	●	—	—	—			0.8		
NU-VBGW 160402		●	●						9.525	4.76	0.2
160404		●	●								0.4
160408		●	●				0.8				
160402LT		—	●	—	—	—	0.2				
160404LT		—	●	—	—	—	0.4				
160408LT		—	●	—	—	—	0.8				
160402LS		—	—	▲	—	—	0.2				
160404LS		—	—	▲	—	—	0.4				
160408LS		—	—	▲	—	—	0.8				
160404HS		—	●	—	—	—	0.4				
160408HS		—	●	—	—	—	0.8				

\* LT: for fine boring of hardened steel LS: Continuous cutting HS: for Strong Edge Type

● Coated SUMIBORON One-use Type/Multi corner

2NC-VBGW		Stock			Dimensions (mm)		
		BNC2010	BNC2020	BNC500	Inscribed circle	Thickness	Nose Radius
Cat. No.							
NEW	2NC-VBGW 110302	●	●		6.35	2.38	0.2
	110304	●	●				0.4
	110308	●	●	●			0.8
NEW	2NC-VBGW 160402	●	●		9.525	4.76	0.2
	160404	●	●	●			0.4
	160408	●	●	●			0.8

● Uncoated SUMIBORON One-use Type/Multi corner

2NU-VBGW		Stock				Dimensions (mm)		
		BN7000				Inscribed circle	Thickness	Nose Radius
Cat. No.								
2NU-VBGW 110304		●				6.35	3.18	0.4
110308		●						0.8

▲ mark : To be replaced by new item (Please confirm stock availability)



# SEC-Boring Bars SVJC/SVQC/SVUC/SVZC Type

■ Insert ( Coated / Cermet / Carbide)

## ● 7° Relief E-Class

VCET FX		Stock					Dimensions (mm)		
		ACZ150					Inscribed circle	Thickness	Nose Radius
Cat. No.		ACZ150					6.35	3.18	0.08
VCET 1103008R-FX		●							
1103008L-FX		●							
110301R-FX		●							
110301L-FX		●							
1103018R-FX		●							
1103018L-FX		●							

VCET FY		Stock					Dimensions (mm)		
		ACZ150					Inscribed circle	Thickness	Nose Radius
Cat. No.		ACZ150					6.35	3.18	0.08
VCET 1103008R-FY		●							
1103008L-FY		●							
110301R-FY		●							
110301L-FY		●							
1103018R-FY		●							
1103018L-FY		●							

## ● 7° Relief G-Class

VCGT FC		Stock					Dimensions (mm)		
		AC520U	AC530U	ACZ150	T1000A	T1500A	Inscribed circle	Thickness	Nose Radius
Cat. No.		AC520U	AC530U	ACZ150	T1000A	T1500A	4.76	2.38	<0.4
VCGT 080204MN-FC		●	●	●	●	●			
VCGT 110301MN-FC		●	●	●	●	●			
110302MN-FC		●	●	●	●	●	6.35	3.18	<0.1
110304MN-FC		●	●	●	●	●			
		●	●	●	●	●			

Values for nose radius prefixed with "<" mean minus tolerances.

VCGT FX		Stock					Dimensions (mm)		
		AC520U	AC530U	T1000A	T1500A	T1200A	Inscribed circle	Thickness	Nose Radius
Cat. No.		AC520U	AC530U	T1000A	T1500A	T1200A	6.35	3.18	0.1
VCGT 110301R-FX		●	●	●	●	▲			
110301L-FX		●	●	●	●	▲			
110302R-FX		●	●	●	●	▲			
110302L-FX		●	●	●	●	▲			
110304R-FX		●	●	●	●	▲			
110304L-FX		●	●	●	●	▲			

VCGT FY		Stock					Dimensions (mm)		
		AC520U	AC530U				Inscribed circle	Thickness	Nose Radius
Cat. No.		AC520U	AC530U				6.35	3.18	0.1
VCGT 110301R-FY		●	●						
110301L-FY		●	●						
110302R-FY		●	●						
110302L-FY		●	●						
110304R-FY		●	●						
110304L-FY		●	●						

## ● 7° Relief G-Class

VCGT SI		Stock						Dimensions (mm)				
		AC610M	AC630M	AC510U	AC520U	AC530U	T1500Z	T1000A	T1500A	Inscribed circle	Thickness	Nose Radius
Cat. No.		AC610M	AC630M	AC510U	AC520U	AC530U	T1500Z	T1000A	T1500A	6.35	3.18	0.1
VCGT 110301MN-SI		●	●	●	●	●	●	●	●			
110302MN-SI		●	●	●	●	●	●	●	●			
110304MN-SI		●	●	●	●	●	●	●	●			
110308MN-SI		●	●	●	●	●	●	●	●			
110308MN-SI		●	●	●	●	●	●	●	●			
Cat. No.		AC610M	AC630M	AC510U	AC520U	AC530U	T1500Z	T1000A	T1500A	9.525	4.76	0.1
VCGT 160401MN-SI		●	●	●	●	●	●	●	●			
160402MN-SI		●	●	●	●	●	●	●	●			
160404MN-SI		●	●	●	●	●	●	●	●			
160404MN-SI		●	●	●	●	●	●	●	●			
160404MN-SI		●	●	●	●	●	●	●	●			

Values for nose radius prefixed with "<" mean minus tolerances.

VCGT AW		Stock					Dimensions (mm)		
		H1					Inscribed circle	Thickness	Nose Radius
Cat. No.		H1					9.525	4.76	0.8
VCGT 160408N-AW		●							
160412N-AW		●							

VCGT AG		Stock					Dimensions (mm)		
		H1					Inscribed circle	Thickness	Nose Radius
Cat. No.		H1					6.35	3.18	0.2
VCGT 110302N-AG		●							
110304N-AG		●							
Cat. No.		H1					9.525	4.76	0.8
VCGT 160408N-AG		●							
160412N-AG		●							

## ● 7° Relief M-Class

VCMT FB		Stock					Dimensions (mm)		
		AC530U	T1500Z	T3000Z	T1000A	T1500A	Inscribed circle	Thickness	Nose Radius
Cat. No.		AC530U	T1500Z	T3000Z	T1000A	T1500A	4.76	2.38	0.2
VCMT 080202N-FB		●	●	●	●	●			
080204N-FB		●	●	●	●	●			
Cat. No.		AC530U	T1500Z	T3000Z	T1000A	T1500A	9.525	4.76	0.4
VCMT 160404N-FB		●	●	●	●	●			
160408N-FB		●	●	●	●	●			

VCMT LU		Stock						Dimensions (mm)				
		AC810P	AC820P	AC830P	AC630M	T1500Z	T3000Z	T1000A	T1500A	Inscribed circle	Thickness	Nose Radius
Cat. No.		AC810P	AC820P	AC830P	AC630M	T1500Z	T3000Z	T1000A	T1500A	9.525	4.76	0.4
VCMT 160404N-LU		●	●	●	●	●	●	●	●			
160408N-LU		●	●	●	●	●	●	●	●			

VCMT SU		Stock								Dimensions (mm)				
		AC810P	AC820P	AC830P	AC2000	AC610M	AC630M	AC6030M	AC6040M	AC520U	AC530U	Inscribed circle	Thickness	Nose Radius
Cat. No.		AC810P	AC820P	AC830P	AC2000	AC610M	AC630M	AC6030M	AC6040M	AC520U	AC530U	4.76	2.38	0.4
VCMT 080204N-SU		●	●	●	●	●	●	●	●	●	●			
VCMT 110302N-SU		●	●	●	●	●	●	●	●	●	●			
110304N-SU		●	●	●	●	●	●	●	●	●	●	6.35	3.18	0.4
110308N-SU		●	●	●	●	●	●	●	●	●	●			
110308N-SU		●	●	●	●	●	●	●	●	●	●			
Cat. No.		AC810P	AC820P	AC830P	AC2000	AC610M	AC630M	AC6030M	AC6040M	AC520U	AC530U	9.525	4.76	0.4
VCMT 160404N-SU		●	●	●	●	●	●	●	●	●	●			
160408N-SU		●	●	●	●	●	●	●	●	●	●			

▲ mark : To be replaced by new item (Please confirm stock availability)

# SEC-Boring Bars SVJC/SVQC/SVUC/SVZC Type



■ Insert ( SUMIBORON / SUMIDIA)

- 7° Relief M-Class
- Uncoated SUMIBORON One-use Type

NU-VCGW		Stock					Dimensions (mm)		
		BN1000	BN2000	BN250	BN7000	BN700	Inscribed circle	Thickness	Nose Radius
Cat. No.									
NU-VCGW 080202		●					4.76	2.38	0.2
080204		●							0.4
080208		●							0.8
080202LT		—	●						0.2
080204LT		—	●						0.4
080208LT		—	●						0.8
080202LS		—	—	▲					0.2
080204LS		—	—	▲					0.4
080208LS		—	—	▲					0.8
080202HS		—	—	—	●				0.2
080208HS		—	—	—	●		0.8		
NU-VCGW 110302		●	●	▲			6.35	3.18	0.2
110304		●	●	▲					0.4
110302LS		—	—	▲					0.2
110304LS		—	—	▲					0.4
110302HS		—	—	—	●				0.2
110304HS		—	—	—	●				0.4
NU-VCGW 160404					●	●	6.35	3.18	0.4

\* LT: for fine boring of hardened steel LS: Continuous cutting HS: for Strong Edge Type

- 7° Relief G-Class
- Coated SUMIBORON One-use Type/Multi corner

2NC-VCGW		Stock					Dimensions (mm)		
		BNC2010	BNC2020	BNC100	BNC160	BNC200	Inscribed circle	Thickness	Nose Radius
Cat. No.									
2NC-VCGW 160404		●	●	●	●	●	9.525	4.76	0.4
160408		●	—	●	●	●			0.8
160404LS		—	—	●	●	●			0.4
160408LS		—	—	●	●	●			0.8
160404HS		●	●	●	●	●			0.4
160408HS		●	●	●	●	●			0.8

\* LS: for fine boring of hardened steel HS: for Strong Edge Type

- 7° Relief M-Class
- SUMIBORON

VCMW		Stock			Dimensions (mm)		
		BNX20	BN500		Inscribed circle	Thickness	Nose Radius
Cat. No.							
VCMW 160404		●			9.525	4.76	0.4
160408		●	●				0.8

- 7° Relief M-Class
- SUMIDIA (NF Type)

NF-VCMT		Stock				Dimensions (mm)		
		DA1000	DA2200			Inscribed circle	Thickness	Nose Radius
Cat. No.								
NF-VCMT 160404		●	▲			9.525	4.76	0.4
160408		●	▲					0.8
160412		●	▲					1.2

- SUMIDIA (Break Master)

NF-VCMT LD/GD		Stock				Dimensions (mm)		
		DA1000				Inscribed circle	Thickness	Nose Radius
Cat. No.								
NF-VCMT 110302N-LD		●				6.35	3.18	0.2
110304N-LD		●						0.4
110302N-GD		●						0.2
110304N-GD		●						0.4

\*LD: For Finishing, GD: For Medium Finishing

- SUMIDIA

VCMT		Stock				Dimensions (mm)		
		DA1000	DA2200			Inscribed circle	Thickness	Nose Radius
Cat. No.								
VCMT 160408		●	▲			9.525	4.76	0.8
160412		●	▲					1.2
160412-WF		●	▲					1.2

\*WF : Edge with Special Land for Aluminium Wheel Glossy Finishing



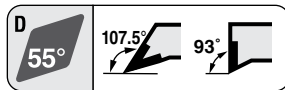

# SEC-Boring Bars S-DDQN/S-DDUN/D-DDUN Type

## Copying

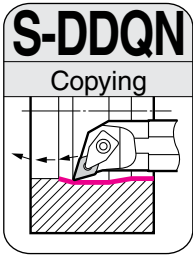

Steel

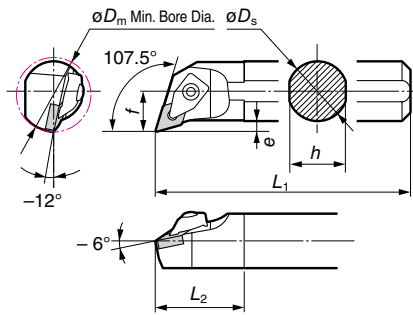

### Insert



· DNMG150408N-GE  
(Representative example)

### Spare Parts

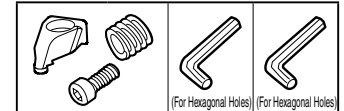

■ Holder Right handed toolholders are applicable with left handed or neutral inserts.  
Left handed toolholders are applicable with right handed or neutral inserts.

Above figures show right hand tools.

Shank	Cat. No.	Conventional Cat. No.	Stock		Dimensions (mm)							Applicable Insert		Clamp Set	Recommended Tightening Torque (N·m)	Wrench for Upper Surface	Wrench for Lower Surface
			R	L	$\phi D_m$	$\phi D_s$	$h$	$L_1$	$f$	$L_2$	$e$	Cat. No.	Featured page				
Steel	S32T-DDQN R/L1504-40	S32T-DDQN R/L15	●	●	40	32	30	300	22	48	6	DN □□1504□□	From B31	SCP-2	5.0	LH040	LH025

Clamp Set Parts E77

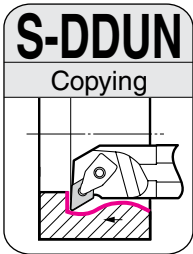

Steel

New

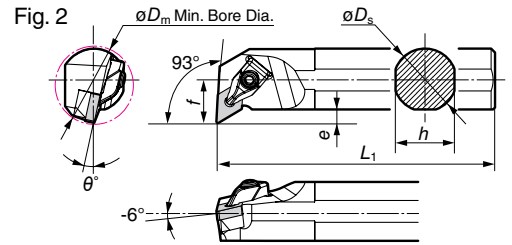
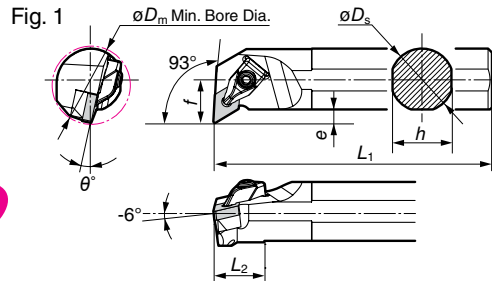

### Spare Parts

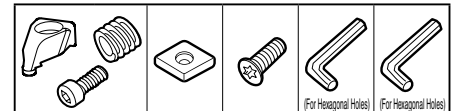

■ Holder Right handed toolholders are applicable with left handed or neutral inserts.  
Left handed toolholders are applicable with right handed or neutral inserts.

Above figures show right hand tools.

Shank	Cat. No.	Stock		Dimensions (mm)							Fig.	Applicable Insert		Clamp Set	Recommended Tightening Torque (N·m)	Shim	Shim Screw	Wrench for Upper Surface	Wrench for Lower Surface
		R	L	$\phi D_m$	$\phi D_s$	$h$	$L_1$	$f$	$L_2$	$e$		Cat. No.	Featured page						
Steel	S32S-DDUN R/L1504-40			40	32	30	250	22.0	26	7.0	1	DN □□1504□□	From B31	SCP-2	5.0	DNS1504B	BFTX0409N	LH040	LH025
	S40T-DDUN R/L1504-50			50	40	37	300	27.0	26	8.5									
	S50U-DDUN R/L1504-63			63	50	47	350	31.5	—	8.0									

Clamp Set Parts E77

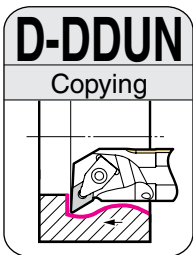

Anti-vibration with oil hole

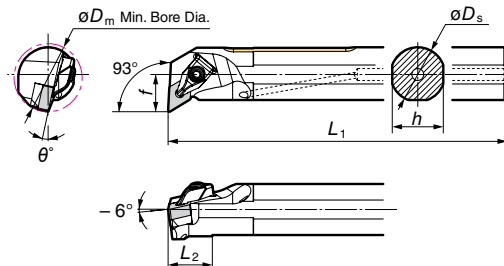

### Insert

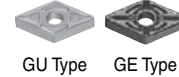

SumiTura Bar

· DNMG110404N-GU  
· DNMG150604N-GE  
(Representative example)

### Spare Parts

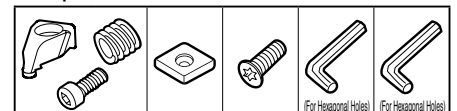

■ Holder Right handed toolholders are applicable with left handed or neutral inserts.  
Left handed toolholders are applicable with right handed or neutral inserts.

Above figures show right hand tools.

Shank	Cat. No.	Stock		Dimensions (mm)							Fig.	Applicable Insert		Clamp Set	Recommended Tightening Torque (N·m)	Shim	Shim Screw	Wrench for Upper Surface	Wrench for Lower Surface
		R	L	$\phi D_m$	$\phi D_s$	$h$	$L_1$	$f$	$L_2$	$\theta^\circ$		Cat. No.	Featured page						
Anti-vibration with oil hole	D32T-DDUN R/L1104-40	●	●	40	32	30	300	22	26	-10	1	DN □□1104□□	B30	SCP-1	5.0	DNS1104B	BFTX0307N	LH040	LH025
	D32T-DDUN R/L1506-40	●	●	40	32	30	300	22	26	-12									
	D40U-DDUN R/L1506-50	●	●	50	40	37	350	27	26	-12									

Clamp Set Parts E77

E Boring Bars

# SEC-Boring Bars S-PDUN/S-EDUN Type

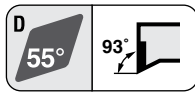

## Copying

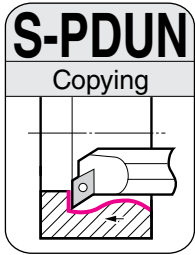

Steel

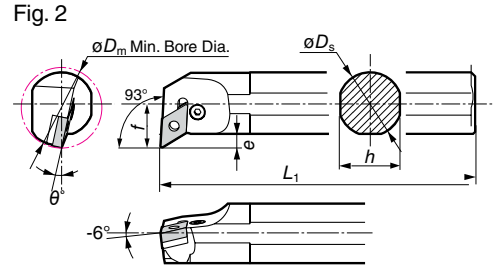
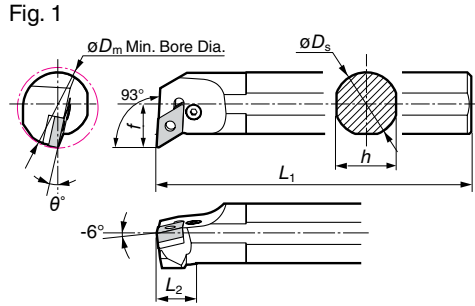

■ Holder Right handed toolholders are applicable with left handed or neutral inserts.  
Left handed toolholders are applicable with right handed or neutral inserts.

Above figures show right hand tools.

Shank	Cat. No.	Conventional Cat. No.	Stock		Dimensions (mm)										Fig.	Applicable Insert Cat. No.	Lever Pin	Clamp Bolt	Shim	Shim Pin	Wrench
			R	L	$\theta D_m$	$\theta D_s$	$h$	$L_1$	$f$	$L_2$	$e$	$\theta$									
Steel	S25R-PDUN R/L1104-32	—	●	●	32	25	22	200	17.0	20	7.0	-15	1	DN □□1104□□	B30	LCL3	LCS3	LSD317	LSP3	LH025	
Steel	S32S-PDUN R/L1504-40	—	●	●	40	32	30	250	22.0	20	7.0	-12	1	DN □□1504□□	From B31	LCL4	LCS4	LSD42	LSP4	LH030	
Steel	S32S-PDUN R/L1504-44	S32S-PDUN R/L15	●	●	44	32	30	250	22.0	20	7.0	-10	1								
Steel	S40T-PDUN R/L1504-50	—	●	●	50	40	37	300	27.0	20	8.5	-12	2								
Steel	S50U-PDUN R/L1504-63	—	●	●	63	50	47	350	31.5	—	8.0	-12	2								

### ■ Spare Parts

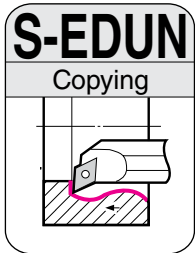
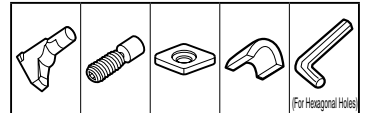

Steel

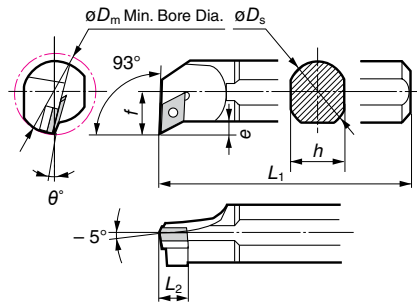

### ■ Insert

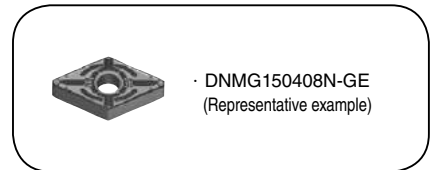

### ■ Spare Parts

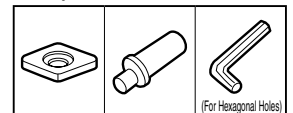

■ Holder Right handed toolholders are applicable with left handed or neutral inserts.  
Left handed toolholders are applicable with right handed or neutral inserts.

Above figures show right hand tools.

Shank	Cat. No.	Conventional Cat. No.	Stock		Dimensions (mm)										Fig.	Applicable Insert		Shim	Eccentric Shaft	Wrench
			R	L	$\theta D_m$	$\theta D_s$	$h$	$L_1$	$f$	$L_2$	$e$	$\theta$	Cat. No.	Featured page						
Steel	S25R-EDUN R/L1104-34	BDUN325 R/L	●	●	34	25	23	200	17	20	5.5	-12	DN □□1104□□	B30	SDW323	CPB34	LH025			
Steel	S32S-EDUN R/L1504-44	BDUN432 R/L	●	●	44	32	30	250	22	20	7.0	-10	DN □□1504□□	From B31	SDW423	CPB43	LH030			

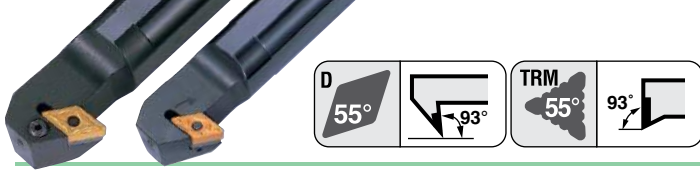

# SEC-Boring Bars S-PDZN/S-EDZN/S-DTR55C Type

## Copying

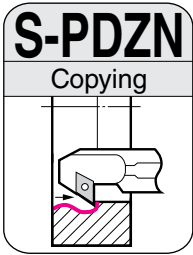

Steel

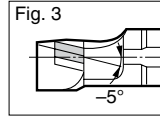
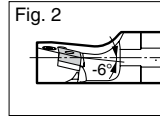
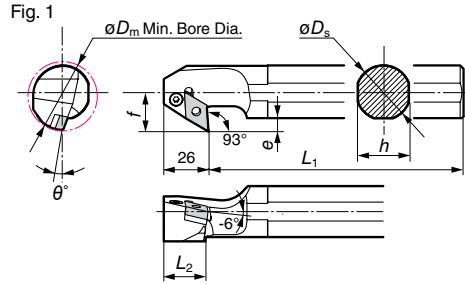

### ■ Insert



· DNMG150408N-GE  
(Representative example)

### ■ Spare Parts

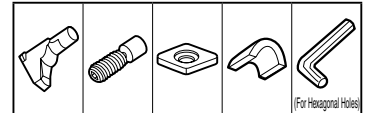

### ■ Holder

Right handed toolholders are applicable with **right handed** or neutral inserts.  
Left handed toolholders are applicable with **left handed** or neutral inserts.

Above figures show right hand tools.

Shank	Cat. No.	Conventional Cat. No.	Stock		Dimensions (mm)							Fig.	Applicable Insert Cat. No.	Featured page	Lever Pin	Clamp Bolt	Shim	Shim Pin	Wrench
			R	L	$\phi D_m$	$\phi D_s$	$h$	$L_1$	$f$	$e$									
Steel	S32S-PDZN R/L1504-40	—	●	●	40	32	30	250	22.0	7.0	2	DN □□1504□□	From B31	LCL4	LCS4	LSD42	LSP4	LH030	
	S32S-PDZN R/L1504-44	S32S-PDZN R/L15	●	●	44	32	30	250	22.0	7.0	1								
	S40T-PDZN R/L1504-50	—	●	●	50	40	37	300	27.0	8.5	2								
	S50U-PDZN R/L1504-63	—	●	●	63	50	47	350	31.5	8.0	3								

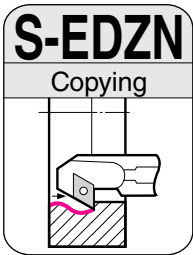

Steel

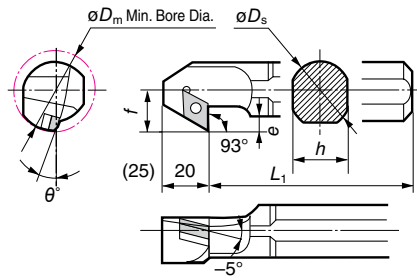

### ■ Insert

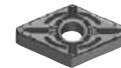

· DNMG150408N-GE  
(Representative example)

### ■ Spare Parts

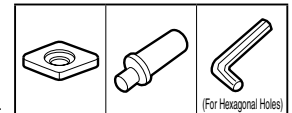

### ■ Holder

Right handed toolholders are applicable with **right handed** or neutral inserts.  
Left handed toolholders are applicable with **left handed** or neutral inserts.

Above figures show right hand tools.

Shank	Cat. No.	Conventional Cat. No.	Stock		Dimensions (mm)										Applicable Insert		
			R	L	$\phi D_m$	$\phi D_s$	$h$	$L_1$	$f$	$L_2$	$e$	$\theta^\circ$	Cat. No.	Featured page	Shim	Eccentric Shaft	Wrench
Steel	S25R-EDZN R/L1104-34	BDZN325 R/L	●	●	34	25	23	200	17	—	5.5	-12	DN □□1104□□	B30	SDW323	CPB34	LH025
	S32S-EDZN R/L1504-44	BDZN432 R/L	●	●	44	32	30	250	22	—	7.0	-10	DN □□1504□□	From B31	SDW423	CPB43	LH030

## Internal Copying

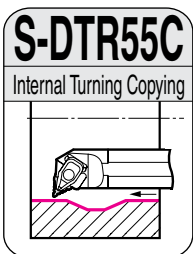

Steel

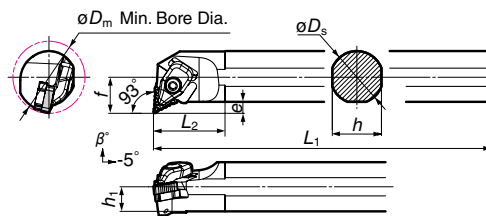

### ■ Insert



Ref. Page : C12  
· TRM551708-GU  
(Representative example)

### ■ Spare Parts

Clamp	Spring	Cap Screw	Recommended Tightening Torque (N·m)	Shim	Shim Screw	Wrench	Shim Wrench
TRCP3	S-SP4-20	BX0520	3.5 to 4.5	TRW5505	BFTX0307N	TSW040	TRX10(*)

### ■ Holder

Cat. No.	Stock	Min. Bore Dia.	Dimensions (mm)							$\beta^\circ$	$e$	$h_1$
			R	$\phi D_m$	$\phi D_s$	$h$	$L_1$	$f$	$L_2$			
S32S-DTR55C R-17	●	44	32	30	250	22	42	-12	7.0	15.0		
S40T-DTR55C R-17	●	50	40	37	300	25	42	-10	6.2	18.5		

\* Item is sold separately.

# SEC-Boring Bars S-SWUB/C-SWUB Type

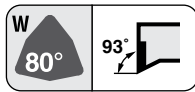

## Small Hole Finishing

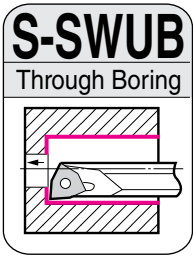

**Steel**

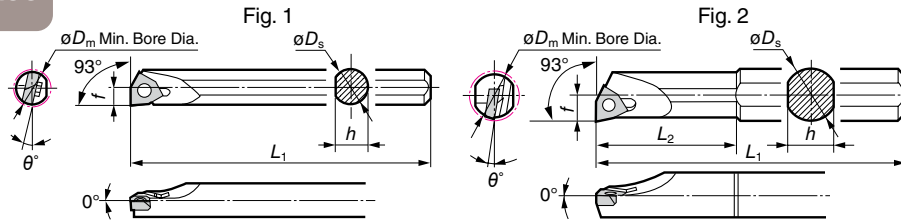

**Sumi Small**

**Holder** Right handed toolholders are applicable with left handed or neutral inserts.  
Left handed toolholders are applicable with right handed or neutral inserts.

Above figures show right hand tools.

**Spare Parts**

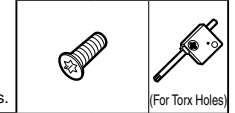

Shank	Cat. No.	Conventional Cat. No.	Stock		Min. Bore Dia. $\theta D_m$	Dimensions (mm)						Fig.	Applicable Insert	Screw	Recommended Tightening Torque (N·m)	Wrench
			R	L		$\theta D_m$	$\theta D_s$	$h$	$L_1$	$f$	$L_2$					
Steel	<b>S05H-SWUB R/L0601-06K</b>	BBPW-508 RK/LK*	●	●	5.5	5	4.7	100	2.75	—	-12	1	WB □□0601□□	BFTX0203N	0.5	TRX06
	<b>S08H-SWUB R/L0601-06</b>	BBPW-508 R/L	●	●	5.5	8	7.0	100	2.75	18	-12	2				
	<b>S08H-SWUB R/L0601-08</b>	BBPW-508 R/L08*	●	●	8.0	8	7.0	100	4	30	-10	2	WB □□0802□□	BFTX02205N	0.5	TRX06
	<b>S08H-SWUB R/L0802-10</b>	BBPW-608 R/L*	●	●	10.0	8	7.0	100	5	18	-13					
	<b>S10K-SWUB R/L0802-12</b>	BBPW-610 R/L*	●	●	12.0	10	9.0	125	6	20	-10					

S05H-SWUB R/L0601-06K requires the sold separately sleeve HBB516.  
The actual product marked with an asterisk (\*) is provided with ISO Cat. No.

	Sleeve	Stock
	HBB 516	●

The sleeve is sold separately.

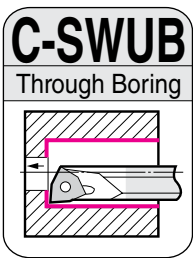

**Carbide**

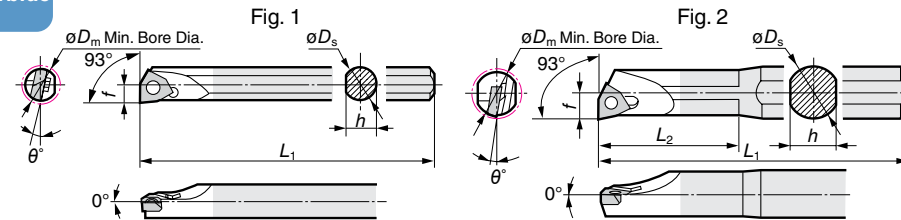

**Sumi Small**

**Holder** Right handed toolholders are applicable with left handed or neutral inserts.  
Left handed toolholders are applicable with right handed or neutral inserts.

Above figures show right hand tools.

**Spare Parts**

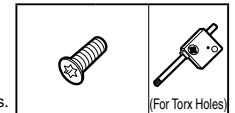

Shank	Cat. No.	Conventional Cat. No.	Stock		Min. Bore Dia. $\theta D_m$	Dimensions (mm)						Fig.	Applicable Insert	Screw	Recommended Tightening Torque (N·m)	Wrench
			R	L		$\theta D_m$	$\theta D_s$	$h$	$L_1$	$f$	$L_2$					
Carbide	<b>C05H-SWUB R/L0601-06K</b>	WBPW-508 RK/LK*	●	●	5.5	5	4.7	100	2.75	—	-12	1	WB □□0601□□	BFTX0203N	0.5	TRX06
	<b>C08K-SWUB R/L0601-06</b>	WBPW-508 R/L	●	●	5.5	8	7.0	125	2.75	30	-12	2				

C05H-SWUB R/L0601-06K requires the sold separately sleeve HBB516.  
The actual product marked with an asterisk (\*) is provided with ISO Cat. No.

	Sleeve	Stock
	HBB 516	●

The sleeve is sold separately.



# SEC-Boring Bars SWUB Type

■ Insert ( Coated / Cermet / SUMIBORON / SUMIDIA )

● 5° Relief G-Class

WBGT FW		Stock				Dimensions (mm)		
		T1500Z	T2000Z	T1500A	T1200A	Inscribed circle	Thickness	Nose Radius
Cat. No.								
WBGT 060102R-FW		●		●	▲	3.97	1.59	0.2
060102L-FW		●	▲	●	▲			0.2
060104R-FW		●		●	▲			0.4
060104L-FW		●	▲	●	▲			0.4
WBGT 080202R-FW		●		●	▲	4.76	2.38	0.2
080202L-FW		●	▲	●	▲			0.2
080204R-FW		●		●	▲			0.4
080204L-FW		●	▲	●	▲			0.4

WBGT FX		Stock				Dimensions (mm)		
		AC510U	AC530U			Inscribed circle	Thickness	Nose Radius
Cat. No.								
WBGT 060102R-FX			●			3.97	1.59	0.2
060102L-FX		●	●					0.2
060104R-FX			●					0.4
060104L-FX		●	●					0.4
WBGT 080202R-FX			●			4.76	2.38	0.2
080202L-FX			●					0.2
080204R-FX			●					0.4
080204L-FX			●					0.4

WBGT FY		Stock				Dimensions (mm)		
		AC530U	T1000A	T1500A	T1200A	Inscribed circle	Thickness	Nose Radius
Cat. No.								
WBGT 0601003L-FY				●		3.97	1.59	0.03
060101R-FY				●				0.1
060101L-FY				●				0.1
060102R-FY		●		●	▲			0.2
060102L-FY		●	●	●	▲			0.2
060104R-FY		●	●	●	▲			0.4
060104L-FY		●	●	●	▲	0.4		
WBGT 080201R-FY			●	●		4.76	2.38	0.1
080201L-FY			●	●				0.1
080202R-FY			●	●				0.2
080202L-FY			●	●				0.2
080204R-FY			●	●				0.4
080204L-FY			●	●				0.4

WBGT W		Stock				Dimensions (mm)		
		T1000A	T1500A	T110A	T1200A	Inscribed circle	Thickness	Nose Radius
Cat. No.								
WBGT 060102R-W		●	●			3.97	1.59	0.2
060102L-W		●	●	▲				0.2
060104R-W		●	●					0.4
060104L-W		●	●	▲				0.4

● 5° Relief E-Class

● SUMIBORON One-use Type

NU-WBEW		Stock				Dimensions (mm)		
		BNX20	BN7000	BN700			Inscribed circle	Thickness
Cat. No.								
NU-WBEW 060102L-LF		—	●	●		3.97	1.59	0.2
060102L-LT		●	—	—				0.2
060104L-LT		●	—	—				0.4
NU-WBEW 080202L-LT		●	—	—		4.76	2.38	0.2
080204L-LT		●	—	—				0.4

\* LF: for sintered component and cast iron machining LT: for fine boring of hardened steel

● 5° Relief M-Class

● SUMIDIA (NF Type)

NF-WBMT		Stock				Dimensions (mm)		
		DA1000				Inscribed circle	Thickness	Nose Radius
Cat. No.								
NF-WBMT 060101L		●				3.97	1.59	0.1
060102L		●						0.2
060104L		●						0.4

● SUMIDIA

WBMT		Stock				Dimensions (mm)		
		DA2200				Inscribed circle	Thickness	Nose Radius
Cat. No.								
WBMT 060101L		▲				3.97	1.59	0.1
060102L		▲						0.2
060104L		▲						0.4

# SEC-Boring Bars S-SWUP Type

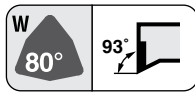

## Small Hole Finishing

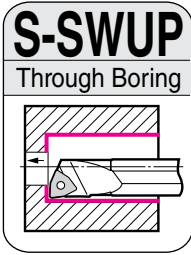

Steel

*New*

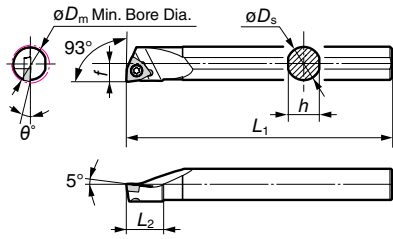

Sumi Small

■ Holder Right handed toolholders are applicable with left handed or neutral inserts.  
Left handed toolholders are applicable with right handed or neutral inserts.

Above figures show right hand tools.

### ■ Spare Parts

Screw	(For Torx Holes)
Recommended Tightening Torque (N·m)	

Shank	Cat. No.	Stock		Dimensions (mm)							Applicable Insert	Screw	Recommended Tightening Torque (N·m)	Wrench
		R	L	$\theta D_m$	$\theta D_s$	$h$	$L_1$	$f$	$L_2$	$\theta^\circ$				
Steel	<i>New</i> S12M-SWUP R/L1102-14	●		14	12	11	150	7	17	-6	WP □□1102□□	BFTX02505N	1.1	TRX08
	<i>New</i> S16Q-SWUP R/L1102-18	●		18	16	15	180	9	18	-3				
	<i>New</i> S16Q-SWUP R/L1603-18	●		18	16	15	180	9	18	-3	WP □□1603□□	BFTX0407N	3.4	TRX15
	<i>New</i> S20R-SWUP R/L1603-22	●		22	20	18	200	11	18	-2				

■ Insert ( Coated / Cermet)

● 11° Relief M-Class

WPMT LB	Cat. No.	Stock					Dimensions (mm)				
		AC820P	AC830P	AC6030M	AC6040M	T1500Z	T3000Z	T1500A	Inscribed circle	Thickness	Nose Radius
<i>New</i>	WPMT 110204N-LB	●	●	●	●	●	●	●	6.35	2.38	0.4
<i>New</i>	WPMT 160308N-LB	●	●	●	●	●	●	●	9.525	3.18	0.8



# SEC-Boring Bars S-SSKP/C-SSKP Type

## General Boring

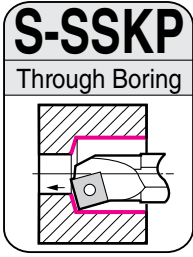

Steel

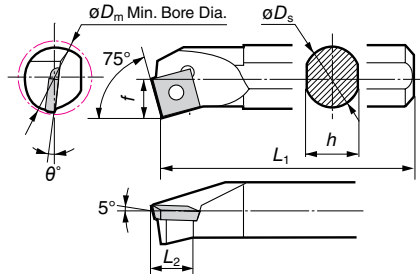

Sumi Small

■ Holder Right handed toolholders are applicable with left handed or neutral inserts.  
Left handed toolholders are applicable with right handed or neutral inserts.

Above figures show right hand tools.

Shank	Cat. No.	Conventional Cat. No.	Stock		Dimensions (mm)							Applicable Insert	Screw	Recommended Tightening Torque (N·m)	Wrench
			R	L	Min. Bore Dia. øD <sub>m</sub>	øD <sub>s</sub>	h	L <sub>1</sub>	f	L <sub>2</sub>	θ°				
Steel	S12M-SSKP R/L0903-16	BBPS-312 R/L	●	●	16	12	11	150	8.0	9.0	-6	SP □□0903□□	BFTX0307A	2.0	TRX10
	S16R-SSKP R/L0903-20	BBPS-316 R/L	●	●	20	16	15	200	10.0	6.8	-4				
	S20S-SSKP R/L0903-25	BBPS-320 R/L	●	●	25	20	18	250	12.5	8.5	-2				
	S25T-SSKP R/L0903-28	BBPS-325 R/L	●	●	28	25	22	300	14.0	5.0	0				

### ■ Spare Parts

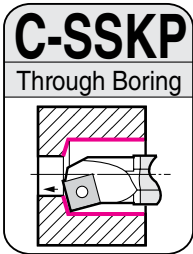
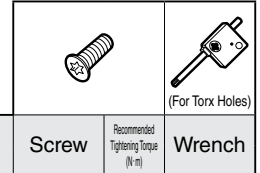

Carbide

Carbide  
Long

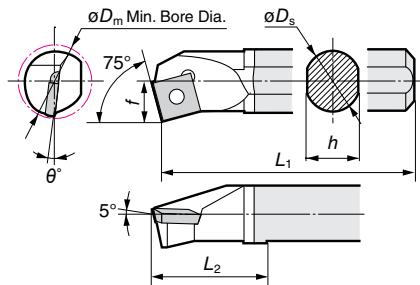

Sumi Small

■ Holder Right handed toolholders are applicable with left handed or neutral inserts.

Shank	Cat. No.	Conventional Cat. No.	Stock		Dimensions (mm)							Applicable Insert	Screw	Recommended Tightening Torque (N·m)	Wrench
			R	L	Min. Bore Dia. øD <sub>m</sub>	øD <sub>s</sub>	h	L <sub>1</sub>	f	L <sub>2</sub>	θ°				
Carbide	C12M-SSKP R0903-16	WBPS-312 R S	●	●	16	12	11	150	8	25	-6	SP □□0903□□	BFTX0307A	2.0	TRX10
Carbide	C12R-SSKP R0903-16	WBPS-312 R	●	●	16	12	11	200	8	25	-6				
Carbide (long)	C16S-SSKP R0903-20	WBPS-316 R	●	●	20	16	15	250	10	30	-4				

### ■ Spare Parts

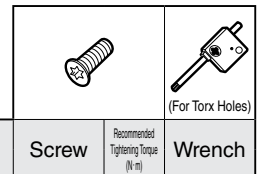

■ Insert ( Coated / Cermet / Carbide)

### ● 11° Relief G-Class

SPGT SD	Stock	Dimensions (mm)		
		Inscribed circle	Thickness	Nose Radius
Cat. No.	T1500Z T3000Z T2000Z T1000A T1500A T110A T1200A ST10P G10E	●	●	●
SPGT 090302R-SD	●	9.525	3.18	0.2
090302L-SD	▲			0.2
090304R-SD	●			0.4
090304L-SD	▲			0.4
090308R-SD	●			0.8
090308L-SD	▲			0.8

SPGW	Stock	Dimensions (mm)		
		Inscribed circle	Thickness	Nose Radius
Cat. No.	G10E	●		
SPGW 090304	●	9.525	3.18	0.4

### ● 11° Relief M-Class

SPMT FB	Stock	Dimensions (mm)		
		Inscribed circle	Thickness	Nose Radius
Cat. No.	AC530U T1500Z T3000Z T1000A T1500A	●	●	●
SPMT 090304N-FB	●	9.525	3.18	0.4
090308N-FB	●			0.8

SPMT LU	Stock	Dimensions (mm)		
		Inscribed circle	Thickness	Nose Radius
Cat. No.	AC810P AC820P AC2000 AC630M AC6030M T3000Z T1000A T1500A T1200A	●	▲	●
SPMT 090304N-LU	●	9.525	3.18	0.4
090308N-LU	●			0.8

SPMT SF	Stock	Dimensions (mm)		
		Inscribed circle	Thickness	Nose Radius
Cat. No.	AC820P AC830P AC2000	●	●	▲
SPMT 090304N-SF	●	9.525	3.18	0.4
090308N-SF	▲			0.8

▲ mark : To be replaced by new item (Please confirm stock availability)

Boring Bars

# SEC-Boring Bars S-SSKC Type

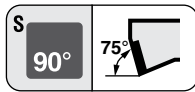

## General Boring

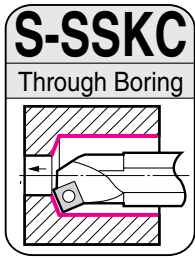

Steel

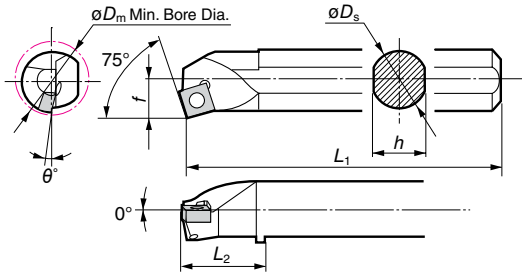

SumiSmall

### Spare Parts

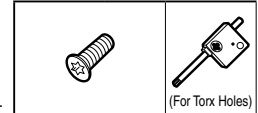

Holder Right handed toolholders are applicable with left handed or neutral inserts.  
Left handed toolholders are applicable with right handed or neutral inserts.

Above figures show right hand tools.

Shank	Cat. No.	Conventional Cat. No.	Stock		Dimensions (mm)							Applicable Insert	Screw	Recommended Tightening Torque (N·m)	Wrench
			R	L	Min. Bore Dia. øD <sub>m</sub>	øD <sub>s</sub>	h	L <sub>1</sub>	f	L <sub>2</sub>	θ°				
Steel	S16R-SSKC R/L09T3-20	S16R-SSKC R/L09	●	●	20	16	15	200	11	23	-10	SC □□09T3□□	BFTX0407N	3.4	TRX15
	S20S-SSKC R/L09T3-25	S20S-SSKC R/L09	●	●	25	20	18	250	13	27	-8		BFTX0409N	3.4	
	S25T-SSKC R/L1204-32	S25T-SSKC R/L12	●	▲	32	25	23	300	17	30	-7	SC □□1204□□	BFTX0511N	5.0	TRX20
	S32U-SSKC R/L1204-40	S32U-SSKC R/L12	●	▲	40	32	30	350	22	33	-6				

Insert ( Coated / Cermet / SUMIDIA)

### 7° Relief G-Class

SCGT FX	Stock	Dimensions (mm)		
		Inscribed circle	Thickness	Nose Radius
Cat. No.	AC530U			
SCGT 09T302R-FX	●	9.525	3.97	0.2
09T302L-FX	●			0.2
09T304R-FX	●			0.4
09T304L-FX	●			0.4
SCGT 120404R-FX	●	12.70	4.76	0.4
120404L-FX	●			0.4

SCGT SC	Stock	Dimensions (mm)		
		Inscribed circle	Thickness	Nose Radius
Cat. No.	AC530U, T1000A, T1500A			
SCGT 09T301MN-SC	●	9.525	3.97	<0.1
09T302MN-SC	●			>0.2

Values for nose radius prefixed with "<" mean minus tolerances.

### 7° Relief M-Class

SCMT LU	Stock	Dimensions (mm)		
		Inscribed circle	Thickness	Nose Radius
Cat. No.	AC810P, AC820P, AC2000, AC630M, AC6030M, T1500Z, T3000Z, T1000A, T1500A, T1200A			
SCMT 09T304N-LU	●	9.525	3.97	0.4
09T308N-LU	●			0.8

SCMT FP	Stock	Dimensions (mm)		
		Inscribed circle	Thickness	Nose Radius
Cat. No.	T1500A, T1200A			
SCMT 09T304N-FP	●	9.525	3.97	0.4
09T308N-FP	●			0.8
SCMT 120404N-FP	●	12.70	4.76	0.4
120408N-FP	●			0.8

SCMT FB	Stock	Dimensions (mm)		
		Inscribed circle	Thickness	Nose Radius
Cat. No.	AC530U, T1500Z, T3000Z, T1000A, T1500A			
SCMT 09T304N-FB	●	9.525	3.97	0.4
09T308N-FB	●			0.8

### 7° Relief M-Class

SCMT SU	Stock	Dimensions (mm)		
		Inscribed circle	Thickness	Nose Radius
Cat. No.	AC810P, AC820P, AC830P, AC2000, AC610M, AC630M, AC6030M			
SCMT 09T304N-SU	●	9.525	3.97	0.4
09T308N-SU	●			0.8
SCMT 120404N-SU	●	12.7	4.76	0.4
120408N-SU	●			0.8

SCMT MU	Stock	Dimensions (mm)		
		Inscribed circle	Thickness	Nose Radius
Cat. No.	AC810P, AC820P, AC2000, AC630M, AC6030M, AC405K, AC415K, AC420K, AC410K			
SCMT 09T308N-MU	●	9.525	3.97	0.8
SCMT 120408N-MU	●	12.7	4.76	0.8

SCMW —	Stock	Dimensions (mm)		
		Inscribed circle	Thickness	Nose Radius
Cat. No.	AC405K, AC415K, AC420K, AC410K			
SCMW 09T308	●	9.525	3.97	0.8
SCMW 120408	●	12.7	4.76	0.8
120412	●			1.2

### SUMIDIA

SCMT —	Stock	Dimensions (mm)		
		Inscribed circle	Thickness	Nose Radius
Cat. No.	DA150			
SCMT 09T301	▲	9.525	3.97	0.1
09T302	▲			0.2
09T304	▲			0.4

▲ mark : To be replaced by new item (Please confirm stock availability)



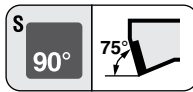

# SEC-Boring Bars S-CSKP Type

## General Boring (Top Clamp Type)

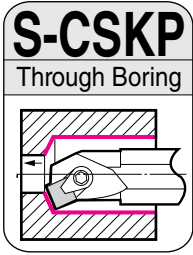

Steel

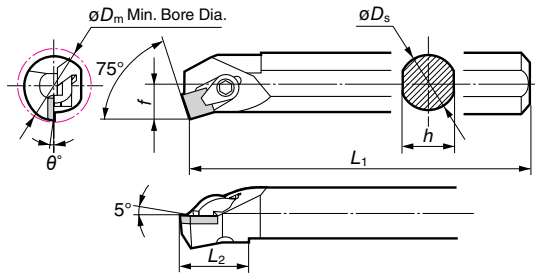

### Spare Parts

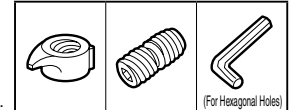

■ Holder Right handed toolholders are applicable with left handed or neutral inserts.  
Left handed toolholders are applicable with right handed or neutral inserts.

Above figures show right hand tools.

Shank	Cat. No.	Conventional Cat. No.	Stock		Dimensions (mm)							Applicable Insert	Clamp	Double Screw	Wrench
			R	L	Min. Bore Dia. øD <sub>m</sub>	øD <sub>s</sub>	h	L <sub>1</sub>	f	L <sub>2</sub>	θ°				
Steel	S16Q-CSKP R/L0903-20	S16Q-CSKP R/L09	●	●	20	16	15	180	10.0	28	-4	SP □□0903□□	CCM6B L/R	WB6-10 WB6-13	LH030
	S20R-CSKP R/L0903-25	S20R-CSKP R/L09	●	●	25	20	18	200	12.5	28	-2				

■ Insert ( Coated / Cermet / Carbide / SUMIBORON / SUMIDIA)

### ● 11° Relief G-Class

SPGR W	Image	Stock						Dimensions (mm)		
		ST10P	Inscribed circle	Thickness	Nose Radius					
Cat. No.										
SPGR 090304L-W		●	9.525	3.18	0.4					

SPGN	Image	Stock						Dimensions (mm)				
		AC510J	T1000A	T1500A	T110A	T1200A	G10E	H1	NB90S	Inscribed circle	Thickness	Nose Radius
Cat. No.												
SPGN 090304 090308		●	●	●	▲	●	●	●	9.525	3.18	0.4 0.8	

### ● Uncoated SUMIBORON One-use Type

(●▲ : 1pc. per package stock, ●▲ : 1pc. per package and 10pc. per package stock)

NU-SPGN	Image	Stock						Dimensions (mm)			
		BNX20	BN2000	BN250	BN500	BN7000	BN700	Inscribed circle	Thickness	Nose Radius	
Cat. No.											
NU-SPGN 090304 090308		●	●	▲	●	○	●	9.525	3.18	0.4 0.8	
090304LT		—	—	—	—	—	—			0.4	
090308LT		—	—	—	—	—	—			0.8	
090304LS		—	—	▲	—	—	—			0.4	
090308LS		—	—	—	—	—	—			0.8	
090304HS		—	●	—	—	—	—			0.4	
090308HS		—	●	—	—	—	—	0.8			

\* LT: for fine boring of hardened steel LS: Continuous cutting HS: for Strong Edge Type

### ● SUMIBORON

SPGN	Image	Stock					Dimensions (mm)		
		BNX20	BN250	BN500	BN7000	BN700	Inscribed circle	Thickness	Nose Radius
Cat. No.									
SPGN 090304 090308		▲	▲	●	●		9.525	3.18	0.4 0.8

### ● 11° Relief G-Class

#### ● SUMIDIA (NF Type)

NF-SPGN	Image	Stock		Dimensions (mm)		
		DA1000	DA2200	Inscribed circle	Thickness	Nose Radius
Cat. No.						
NF-SPGN 090304 090308		●	▲	9.525	3.18	0.4 0.8

#### ● SUMIDIA

SPGN	Image	Stock				Dimensions (mm)		
		DA150	Inscribed circle	Thickness	Nose Radius			
Cat. No.								
SPGN 090304 090308		●	▲	9.525	3.18	0.4 0.8		

▲ mark : To be replaced by new item (Please confirm stock availability)

# SEC-Boring Bars CSKP Type



■ Insert ( Coated / Cermert / Carbide)

● 11° Relief M-Class

SPMR FK		Stock						Dimensions (mm)		
		T1500Z	T3000Z	T2000Z	T1000A	T1500A	T1200A	Inscribed circle	Thickness	Nose Radius
Cat. No.										
SPMR 090304N-FK		●	●	▲	●	●	▲	9.525	3.18	0.4
090308N-FK		●	●	▲	●	●	▲			0.8

SPMR SF		Stock						Dimensions (mm)		
		AC820P	AC830P	AC2000				Inscribed circle	Thickness	Nose Radius
Cat. No.										
SPMR 090304N-SF		●	●	▲				9.525	3.18	0.4
090308N-SF		●	●	▲						0.8

SPMR UJ		Stock						Dimensions (mm)		
		AC820P	AC830P	AC2000				Inscribed circle	Thickness	Nose Radius
Cat. No.										
SPMR 090304N-UJ		●	●	▲				9.525	3.18	0.4
090308N-UJ		●	●	▲						0.8

SPMN —		Stock										Dimensions (mm)		
		AC405K	AC415K	AC420K	AC410K	T1000A	T1500A	T1200A	ST20E	A30	Inscribed circle	Thickness	Nose Radius	
Cat. No.														
SPMN 090304		●	●	●	▲	●	●	▲	●			9.525	3.18	0.4
090308		●	●	▲	●	●	▲	●						0.8



# SEC-Boring Bars S-DSKN/S-PSKN Type

## General Boring



Steel

New

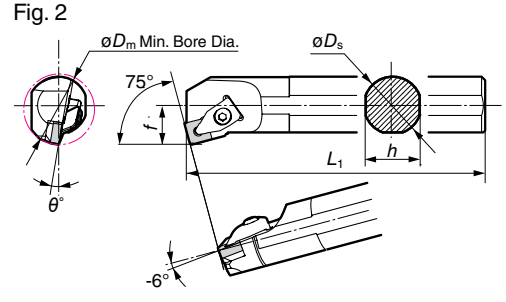
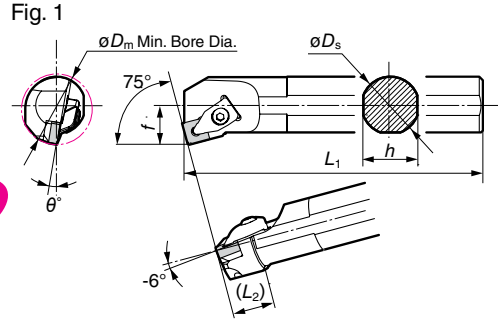

■ Holder Right handed toolholders are applicable with left handed or neutral inserts. Left handed toolholders are applicable with right handed or neutral inserts.

Above figures show right hand tools.

### ■ Spare Parts

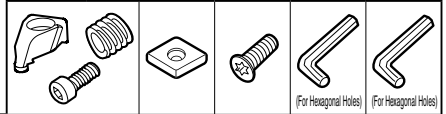

Shank	Cat. No.	Stock		Dimensions (mm)							Fig.	Applicable Insert		Clamp Set	Recommended Tightening Torque (N·m)	Shim	Shim Screw	Wrench for Upper Surface	Wrench for Lower Surface
		R	L	Min. Bore Dia. øD <sub>m</sub>	øD <sub>s</sub>	h	L <sub>1</sub>	f	L <sub>2</sub>	θ°		Cat. No.	Featured page						
Steel	S25R-DSKN R/L1204-32			32	25	23	200	17.0	(26)	-13	1	SN □ □ 1204 □ □	From B41	SCP-2	5.0	SNS1203B	BFTX0307N	LH040	LH025
	S32S-DSKN R/L1204-40			40	32	30	250	22.0	(21)	-10									
	S40T-DSKN R/L1204-50			50	40	37	300	27.0	(21)	-10									
	S50U-DSKN R/L1204-63			63	50	47	350	31.5	—	-10									

( ) is reference value.

Clamp Set Parts E77



Steel

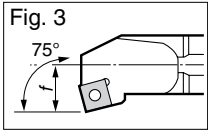
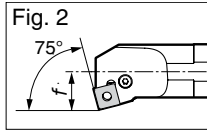
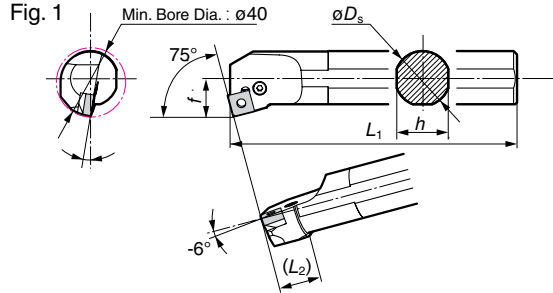

### ■ Insert

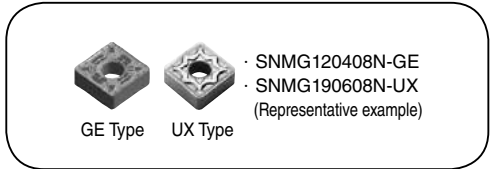

### ■ Spare Parts

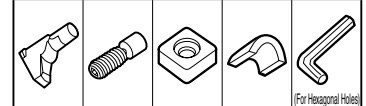

■ Holder Right handed toolholders are applicable with left handed or neutral inserts. Left handed toolholders are applicable with right handed or neutral inserts.

Above figures show right hand tools.

Shank	Cat. No.	Conventional Cat. No.	Stock		Dimensions (mm)							Fig.	Applicable Insert		Lever Pin	Clamp Bolt	Shim	Shim Pin	Wrench
			R	L	Min. Bore Dia. øD <sub>m</sub>	øD <sub>s</sub>	h	L <sub>1</sub>	f	L <sub>2</sub>	θ°		Cat. No.	Featured page					
Steel	S32S-PSKN R/L1204-40	—			40	32	30	250	22.0	(21)	-10	1	SN □ □ 1204 □ □	From B41	LCL4	LCS4	LSS42B	LSP4	LH030
	S32S-PSKN R/L1204-44	S32S-PSKN R/L12	●	●	44	32	30	250	22.0	(21)	-10								
	S40T-PSKN R/L1204-50	—			50	40	37	300	27.0	(21)	-10								
	S40T-PSKN R/L1204-54	S40T-PSKN R/L12	●	●	54	40	37	300	27.0	(21)	-10								
	S50U-PSKN R/L1204-63	—			63	50	47	350	31.5	—	-10								
S50U-PSKN R/L1906-70	S50U-PSKN R/L19	●	●	70	50	47	350	35.0	(31)	-10	1	SN □ □ 1906 □ □	From B45	LCL6	LCS6	LSS63	LSP6	LH040	

( ) is reference value.

E Boring Bars

# SEC-Boring Bars S-PSYN/S-ESKN/S-ESYN Type

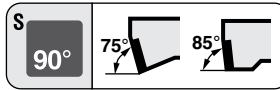

## General Boring

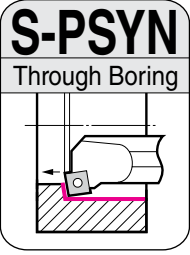

**Steel**

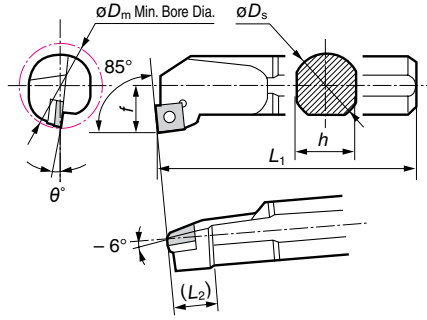

### Insert

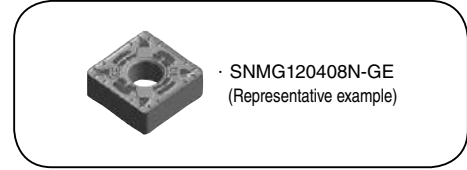

### Spare Parts

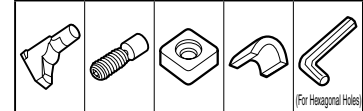

**Holder** Right handed toolholders are applicable with left handed or neutral inserts.  
Left handed toolholders are applicable with right handed or neutral inserts.

Above figures show right hand tools.

Shank	Cat. No.	Conventional Cat. No.	Stock		Dimensions (mm)							Applicable Insert		Lever Pin	Clamp Bolt	Shim	Shim Pin	Wrench
			R	L	$\phi D_m$	$\phi D_s$	$h$	$L_1$	$f$	$L_2$	$\theta^\circ$	Cat. No.	Featured page					
Steel	<b>S32S-PSYN R/L1204-44</b>	S32S-PSYN R/L12	●	●	44	32	30	250	22	(22)	-10	SN □□1204□□	From B41	LCL4	LCS4	LSS42B	LSP4	LH030

( ) is reference value.



**Steel**

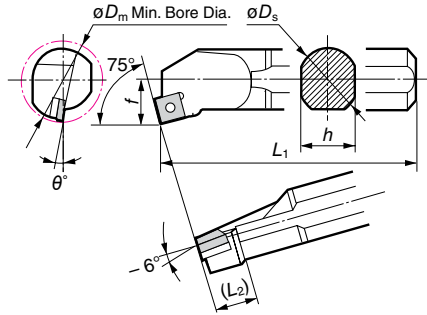

### Insert

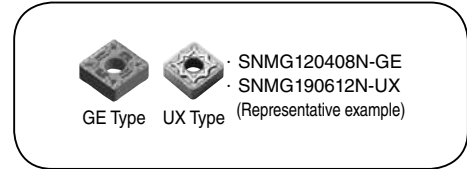

### Spare Parts

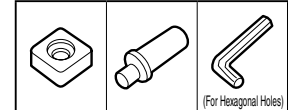

**Holder** Right handed toolholders are applicable with left handed or neutral inserts.  
Left handed toolholders are applicable with right handed or neutral inserts.

Above figures show right hand tools.

Shank	Cat. No.	Conventional Cat. No.	Stock		Dimensions (mm)							Applicable Insert		Shim	Eccentric Shaft	Wrench
			R	L	$\phi D_m$	$\phi D_s$	$h$	$L_1$	$f$	$L_2$	$\theta^\circ$	Cat. No.	Featured page			
Steel	<b>S25R-ESKN R/L1204-34</b>	BSKN425 R/L	●	●	34	25	23	200	17	(18)	-12	SN □□1204□□	From B41	SSW423	CPB42	LH030
	<b>S32S-ESKN R/L1204-44</b>	BSKN432 R/L	●	●	44	32	30	250	22	(20)	-10					
	<b>S40T-ESKN R/L1204-54</b>	BSKN440 R/L	●	●	54	40	37	300	27	(20)	-10					
	<b>S50U-ESKN R/L1906-70</b>	BSKN650 R/L	●	●	70	50	47	350	35	(30)	-10					

( ) is reference value.

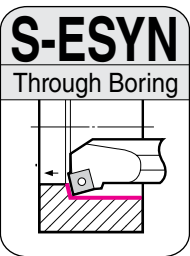

**Steel**

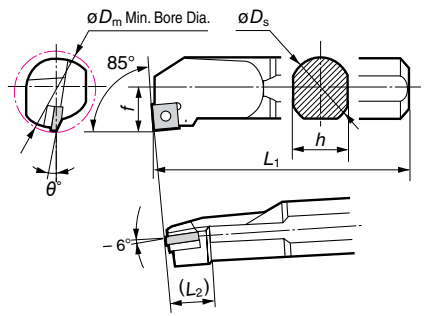

### Insert

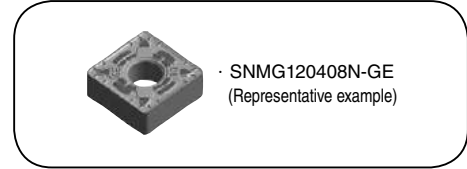

### Spare Parts

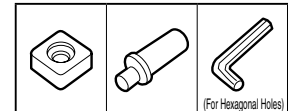

**Holder** Right handed toolholders are applicable with left handed or neutral inserts.  
Left handed toolholders are applicable with right handed or neutral inserts.

Above figures show right hand tools.



Shank	Cat. No.	Conventional Cat. No.	Stock		Dimensions (mm)							Applicable Insert		Shim	Eccentric Shaft	Wrench
			R	L	$\phi D_m$	$\phi D_s$	$h$	$L_1$	$f$	$L_2$	$\theta^\circ$	Cat. No.	Featured page			
Steel	<b>S25R-ESYN R/L1204-34</b>	BSYN425 R/L	●	●	34	25	23	200	17	(20)	-12	SN □□1204□□	From B41	SSW423	CPB42	LH030
	<b>S32S-ESYN R/L1204-44</b>	BSYN432 R/L	●	●	44	32	30	250	22	(22)	-10					

( ) is reference value.

# Double Clamp Tool Holders

## Clamp Set Parts

### ■ Spare Parts

Applicable Clamp Sets	Clamp plate		Spring		Cap Screw		Recommended Tightening Torque (N · m)
							
	Can be screwed from under the screw as well.						
	Cat. No.	Stock	Cat. No.	Stock	Cat. No.	Stock	
SCP-1	<b>CP1</b>	●	<b>CSP08</b>	●	<b>CP-M5-20-1</b>	●	5.0
SCP-2	<b>CP2</b>	●	<b>CSP08</b>	●	<b>CP-M5-20-1</b>	●	
SCP-3	<b>CP3</b>	●	<b>CSP08</b>	●	<b>CP-M5-20-1</b>	●	
SCP-4	<b>CP4</b>	●	<b>CSP08</b>	●	<b>CP-M5-20-1</b>	●	
SCP-5	<b>CP5</b>	●	<b>CSP08</b>	●	<b>CP-M5-20-1</b>	●	
SCP-6	<b>CP6</b>	●	<b>CSP12</b>	●	<b>CP-M8-30-1</b>	●	